

**FläktGroup**

AIRTREND Ltd  
Predstavništvo u Beogradu  
Kumanovska 14, 11000 Beograd  
Tel: 011/3836886, 3085740  
Faks: 011/3444113  
e-mail: gobrid@eunet.rs  
web: www.airtrend.rs

# Fan Coil Units

FLEX-GEKO<sup>®</sup>  
TECHNICAL DATA

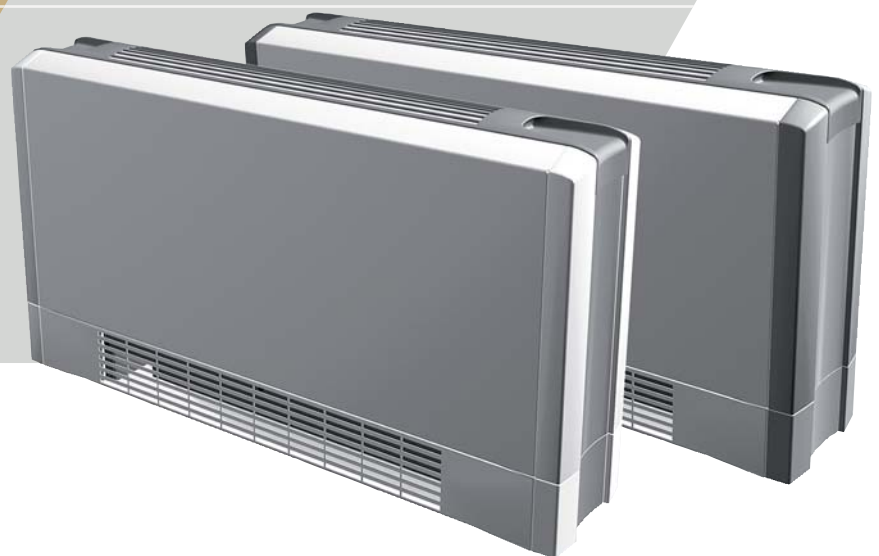

<b>Model sizes</b> .....	<b>3</b>
<b>Fan coil unit components</b> .....	<b>4</b>
<b>Unit selection</b> .....	<b>5</b>
<b>Unit description</b> .....	<b>8</b>
<b>EC technology: Keyword Energy Efficiency</b> .....	<b>8</b>
<b>Recirculating-Air Unit Heating and Cooling 4-pipe chilled and warm water</b> .....	<b>12</b>
<b>Recirculating-Air Unit Heating and Cooling 2-pipe chilled water and electric heating</b> .....	<b>16</b>
<b>Recirculating-Air Unit Heating and Cooling Direct evaporator and 2-pipe warm water</b> .....	<b>20</b>
<b>Recirculating-Air Unit Heating or Cooling 2-pipe chilled or warm water</b> .....	<b>24</b>
<b>Recirculating-Air Unit Heating or Cooling 2-pipe chilled or warm water with Electric Auxiliary Heating</b> .....	<b>28</b>
<b>Recirculating-Air Unit Heating 2-pipe warm water</b> .....	<b>32</b>
<b>Recirculating-Air Unit Heating Full Electric Heating</b> .....	<b>36</b>
<b>Recirculating-Air Unit Cooling 2-pipe chilled water</b> .....	<b>40</b>
<b>Recirculating-Air Unit Cooling Direct evaporator</b> .....	<b>44</b>
<b>Mixed-Air Unit Heating and Cooling 4-pipe chilled and warm water</b> .....	<b>48</b>
<b>Mixed-Air Unit Heating and Cooling Direct Evaporator and 2-pipe warm water</b> .....	<b>52</b>
<b>Mixed-Air Unit Heating or Cooling 2-pipe chilled or warm water</b> .....	<b>56</b>
<b>Mixed-Air Unit Heating 2-pipe warm water</b> .....	<b>60</b>
<b>Mixed-Air Unit Heating Full electric heating</b> .....	<b>64</b>
<b>Pressure drop in heat exchanger</b> .....	<b>68</b>
<b>Samples for capacity definition</b> .....	<b>69</b>
<b>Acoustics</b> .....	<b>70</b>
<b>Sound power level and sound pressure level</b> .....	<b>72</b>
<b>NR and NC limiting curves</b> .....	<b>73</b>
<b>Definition of Airflow/Installation Samples</b> .....	<b>74</b>
<b>Dimensions of basic units without casing</b> .....	<b>75</b>
<b>Dimensions and medium connections</b> .....	<b>76</b>
<b>Dimensions of unit casing</b> .....	<b>77</b>
<b>Accessory sizes - Geko-Drive</b> .....	<b>79</b>
<b>Accessory sizes - Air-side accessories</b> .....	<b>80</b>
<b>Valve control mode</b> .....	<b>84</b>
<b>Overview of valves</b> .....	<b>85</b>
Selection table .....	85
Valves (supplied separately) with modulating actuator (230 V~ and 24 V~)/3-point operation ....	86
Valves with reversible actuator (230 V~) and 2 floating auxiliary switches/3-point operation .....	87
Valves with thermoelectric actuators (230 V~ and 24 V~)/2-point open/close operation .....	88
Valves with continuous actuator (24 V~, 0 ... 10 V) .....	89
Thermostatic expansion valve .....	90
Shut-off valves .....	91
Ball cocks .....	92
<b>Control via thermostat / miniature switch, controls by others</b> .....	<b>93</b>
<b>Functions of thermostat and miniature switch</b> .....	<b>94</b>
<b>MATRIX® controls</b> .....	<b>95</b>
System Description .....	96
Overview of Features .....	97
Mounting control panels .....	98
Sensors/Accessories .....	99
Global modules.....	100
MATRIX.Clock module .....	101
MATRIX.PC service software .....	101
Control Panel for All Groups .....	102
<b>Unit type code</b> .....	<b>103</b>

Model size	Width [mm]	Air volume [m <sup>3</sup> /h]	Sound pressure level <sup>1)</sup> [dB(A)]	Capacity <sup>2)</sup> [kW]		Motor type	EnEff class <sup>3)</sup>	
				Heating capacity $\dot{Q}_H$	Cooling capacity $\dot{Q}_K$		Heating	Cooling
1	840	145-530	<20-50	0.6-5,5	0.9-3,0	AC	ABCDEF G	ABCDEF G
				EC		ABCDEF G	ABCDEF G	
2	990	155-540	<20-49	1.0-6,2	1.0-3,4	AC	ABCDEF G	ABCDEF G
				EC		ABCDEF G	ABCDEF G	
3	1140	275-890	21-51	1.7-9,6	1.7-5,3	AC	ABCDEF G	ABCDEF G
				EC		ABCDEF G	ABCDEF G	
4	1290	285-990	20-51	1.9-11,1	2.0-6,2	AC	ABCDEF G	ABCDEF G
				EC		ABCDEF G	ABCDEF G	
5	1440	295-1010	20-51	2.1-12,1	2.0-6,7	AC	ABCDEF G	ABCDEF G
				EC		ABCDEF G	ABCDEF G	
6	1590	425-1310	24-54	2.9-14,2	2.6-7,6	AC	ABCDEF G	ABCDEF G
				EC		ABCDEF G	ABCDEF G	
7	1740	455-1420	24-55	3.2-15,9	2.9-8,7	AC	ABCDEF G	ABCDEF G
				EC		ABCDEF G	ABCDEF G	
8	1890	575-1820	25-53	3.9-19,6	3.7-10,8	AC	ABCDEF G	ABCDEF G
				EC		ABCDEF G	ABCDEF G	

1) Ambient conditions see Acoustics on Page 70

2) Capacity data only apply to medium water. Input parameters: PWW 70/50°C, tL1 = +20 °C; PCW 6/12 °C, tL1 = 27 °C, 46 % r.h.  
With other input parameters the following correction factors for approximate estimation of performance data should be applied.

3) EnEff class = Energy Efficiency Class according to EUROVENT refer to Page 10.

### Correction factors <sup>4)</sup>

The correction factors listed below can be used to calculate the capacity data in accordance with EUROVENT classification conditions:

Cooling in recirculating mode (2+4-pipe system): 1.00

Heating in recirculating mode (2-pipe system): 0.66

Heating in recirculating mode (4-pipe system): 1.25

Sound power level <sup>5)</sup> +2 dB

#### Correction factors $f_K$ for cooling capacity $\dot{Q}_K$

Chilled water temp. [°C]	Air intake: t <sub>L1</sub> [°C], φ <sub>1</sub> [% r.h.]				
	32/40	30/40	27/46	26/50	24/50
6/12	1.40	1.18	1.00	0.97	0.76
7/12	1.39	1.16	0.98	0.95	0.75
8/12	1.37	1.14	0.96	0.93	0.73
8/14	1.20	0.99	0.82	0.76	0.56
10/15	1.08	0.87	0.71	0.66	0.49
12/16	0.95	0.76	0.59	0.54	0.42
12/18	0.83	0.66	0.50	0.44	—
14/18	0.77	0.60	0.46	0.42	0.32

#### Correction factors $f_H$ for heating capacity $\dot{Q}_H$ (recirculating air t<sub>L1</sub> = 20 °C)

Warm water temperature [°C]	2-pipe system Air intake: t <sub>L1</sub> [°C]			4-pipe system Air intake: t <sub>L1</sub> [°C]		
	+10	+15	+20	+10	+15	+20
90/70	1.77	1.65	1.53	2.02	1.86	1.70
80/60	1.51	1.39	1.27	1.67	1.51	1.34
70/55	1.32	1.20	1.07	1.47	1.32	1.15
70/50	1.25	1.13	1.00	1.33	1.15	1.00
60/50	1.12	1.00	0.88	1.32	1.15	0.98
60/40	0.98	0.85	0.72	0.90	—	—
50/40	0.87	0.74	0.62	0.95	0.79	0.63
40/30	0.61	0.48	0.33	0.62	0.62	—

#### Correction factors $f_H$ for heating capacity $\dot{Q}_H$ (mixed-air t<sub>L1</sub> = 10 °C)

Warm water temperature [°C]	2-pipe system Air intake: t <sub>L1</sub> [°C]							4-pipe system Air intake: t <sub>L1</sub> [°C]						
	-10	-5	0	+5	+10	+15	+20	-10	-5	0	+5	+10	+15	+20
90/70	1.80	1.70	1.61	1.51	1.41	1.32	1.22	2.00	1.89	1.76	1.64	1.51	1.40	1.28
80/60	1.59	1.50	1.40	1.31	1.21	1.11	1.01	1.72	1.60	1.49	1.37	1.26	1.14	1.02
70/55	1.43	1.34	1.24	1.15	1.05	0.95	0.85	1.60	1.48	1.35	1.23	1.11	1.00	0.88
70/50	1.39	1.29	1.20	1.10	1.00	0.90	0.80	1.46	1.35	1.23	1.11	1.00	0.83	0.71
60/50	1.27	1.17	1.08	0.99	0.89	0.80	0.70	1.49	1.36	1.24	1.11	0.99	0.86	0.74
60/40	1.18	1.09	0.99	0.89	0.79	0.68	0.57	1.20	1.08	0.97	0.82	—	—	—
50/40	1.08	0.98	0.89	0.79	0.69	0.59	0.49	1.22	1.09	0.96	0.84	0.72	0.60	0.47
40/30	0.88	0.78	0.68	0.59	0.49	0.38	0.27	0.94	0.82	0.70	0.58	0.44	—	—

4) All indicated correction factors are arithmetically calculated for different unit configurations and are provided for approximate calculations of capacity data using other parameters.  
Exact data and other parameters can be obtained from our staff.

5) Maximum indication due to EUROVENT zero tolerance.

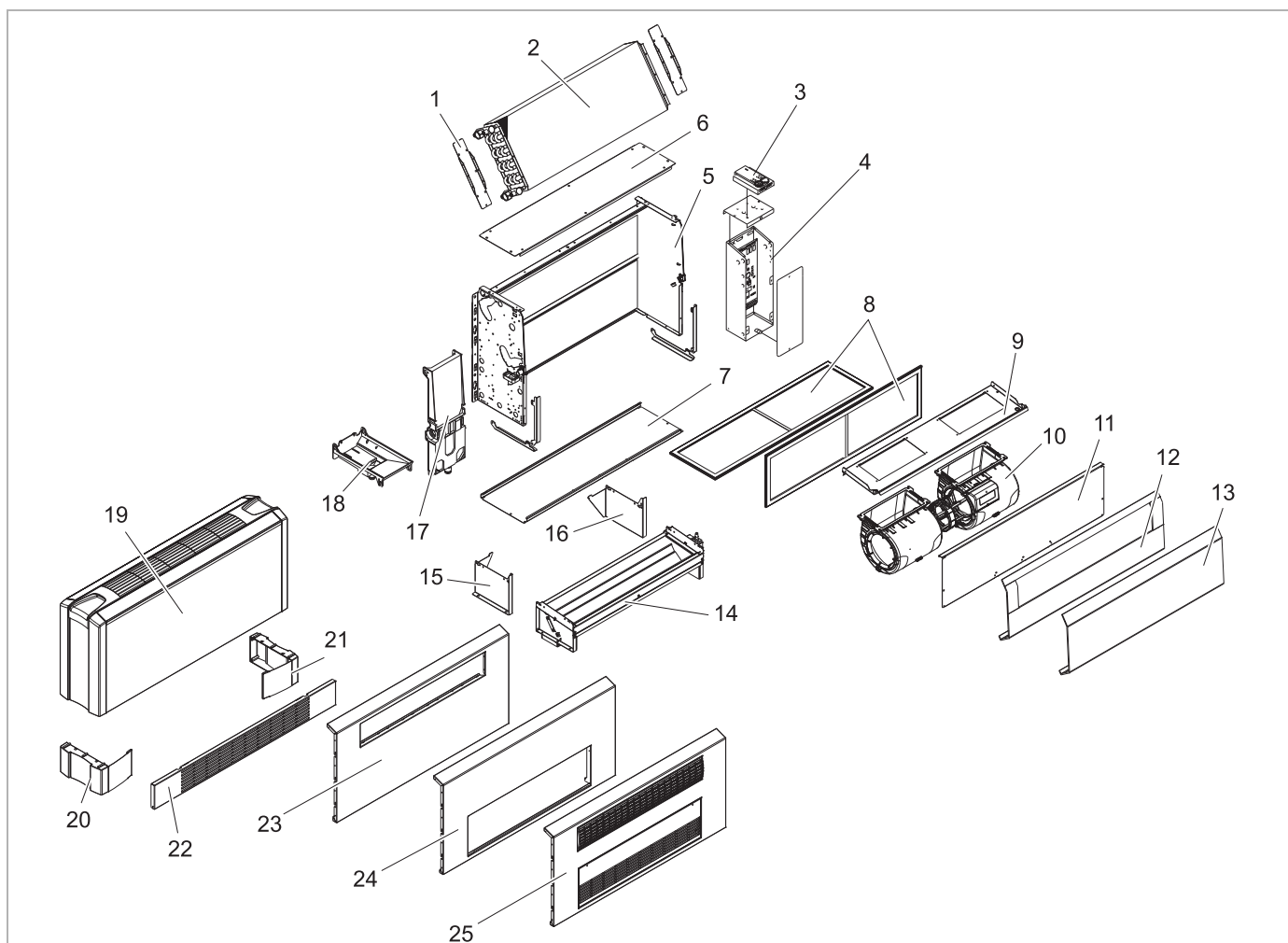

Fig. 1: Unit components (depending on unit model)

- |  |   |
|--|---|
| <ul style="list-style-type: none"> <li>1: Holding plate</li> <li>2: Heat Exchanger</li> <li>3: Control panel</li> <li>4: Metal sheet electric control box</li> <li>5: Basic casing (rear wall with lateral sheet steel panels)</li> <li>6: Cover sheet at discharge on front side</li> <li>7: Bottom panel at intake on front side</li> <li>8: Filter element</li> <li>9: Main drain pan for wall units</li> <li>10: Fan with casing</li> <li>11: Suction side front panel at bottom/rear intake</li> <li>12: Pressure side front panel with frontal discharge</li> <li>13: Pressure side front panel with top discharge (wall unit) and main drain pan for ceiling units and discharge frontal discharge</li> </ul> | <ul style="list-style-type: none"> <li>14: Mixed-air box* with actuator</li> <li>15: Unit foot on left side for recirculating-air unit</li> <li>16: Unit foot on right side for recirculating-air unit</li> <li>17: Lateral ceiling drain pan</li> <li>18: Lateral wall drain pan</li> <li>19: Unit casing</li> <li>20: Unit foot cover, left side</li> <li>21: Unit foot cover, right side</li> <li>22: Suction grille</li> <li>23: Front casing for front side discharge</li> <li>24: Front casing for front side intake</li> <li>25: Front casing for front side intake and discharge</li> </ul> |
|--|---|

\* The plant manufacturer / operator must operate the unit in accordance with EU Directive 1253.











FläktGroup is a participant in the EUROVENT certification program. The certified products are listed in the corresponding EUROVENT lists.

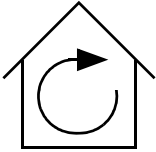
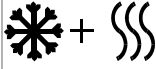

FläktGroup Flex-Geko recirculating-air units are certified in accordance with the hygienic requirements and regulations stipulated by VDI 6022, Sheet 1 (07/11) and SWKI VA 104-01 (04/06).

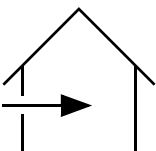
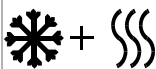



Fans meets requirements of EU Regulation No. 327/2011 of the Commission as of 30th March 2011 to implement Directive 2009/125/EG (ErP-regulation).

			Unit Description	4
<b>Recirculating air</b>  	Cooling and heating		4-pipe chilled and warm water (4-pipe chilled and warm water with auxiliary electric heating)*	12
			2-pipe chilled water and electrical heating	16
			DX evaporator and 2-pipe warm water	20
	Cooling or Heating		2-pipe chilled or warm water	24
			2-pipe chilled or warm water with auxiliary electric heating	28
	Heating		2-pipe warm water (2-pipe warm water with auxiliary electric heating)°	32
			Full electric heating	36
	Cooling		2-pipe chilled water	40
			Direct evaporator	44
	<b>Mixed air**</b>  	Cooling and heating		4-pipe chilled and warm water (2-pipe chilled water and electrical heating)*
DX evaporator and 2-pipe warm water				52
Cooling or heating			2-pipe chilled or warm water (2-pipe chilled or warm water with auxiliary electric heating)*	56
			Heating	
Full electric heating		64		
Cooling			(2-pipe chilled water)*	—
			(DX evaporator)*	—

\*On request FläktGroup will provide you data on the units indicated in brackets.

\*\*The plant manufacturer / operator must operate the unit in accordance with EU Directive 1253.

	<b>Technical Data, dimensions and specification of accessories</b>	68
	<b>Valves</b>	84
	<b>MATRIX Control System/Thermostat Switches</b>	93

**Ceiling unit**



Fig. 2

**Wall unit with mixed-air box**



Fig. 3

**Recirculating/mixed-air units\***

heating/cooling/filtering/ventilating with 2/4-pipe system. Wall or ceiling installation (electrical and valve equipment depends on functions and requirements), basic unit made of sendzmirgalvanized metal sheet with sound and heat insulation made of polyethylene

**Comfort casing for ceiling unit, adjustable air discharge grille, air intake bottom/rear**



Fig. 4

**Comfort unit casing wall, adjustable air discharge grille (with air intake grille)**

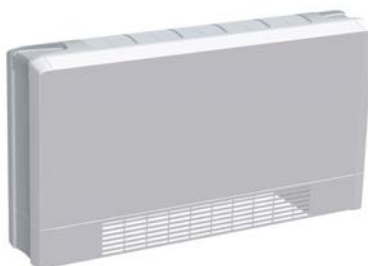

Fig. 5

**Comfort unit casing**

made of painted metal sheet, colour white (similar to RAL 9002); plastic lateral parts and service panels, colour white (similar RAL 9002) and grey (RAL 7035); adjustable plastic air discharge grille, in grey (RAL 7035), or rigid version made of aluminium, naturally anodized

**Thermoelectric valves**



Fig. 6

**Modulating valves**



Fig. 7

**Valves**

2 and 3-way valves with actuators for  
 2-point, 230/24 V~ 50/60 Hz  
 3-point, 230/24 V~ 50/60 Hz  
 continuous 24 V~, control signal 0-10 V,  
 mounted and wired by factory

**Geko-Drive**

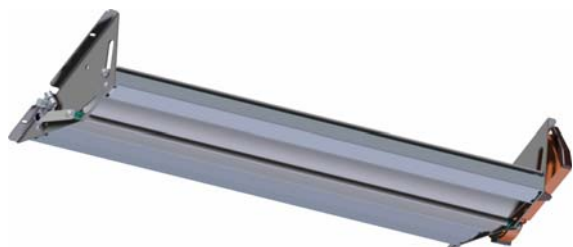

Fig. 8

**Geko-Drive**

Motorized and regulated discharge profile for optimization of flow pattern and air throw in cooling mode, mounted by the factory (in combination with unit casing and MATRIX 4000). For more features see Page 79

**Speed and thermostat switches**



Fig. 9

**MATRIX control system**



Fig. 10

**Control / steering systems**

according to:  
 unit configuration,  
 fitted valves,  
 internal/external  
 electronic components

\*) On the part of the plant manufacturer / operator, the unit must be used in accordance with EU Directive 1253.

**Heat exchanger**  
for warm / chilled water

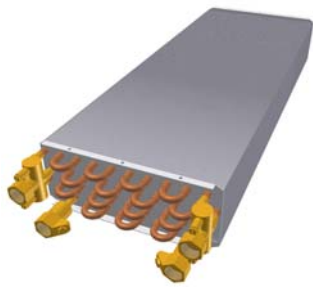

Fig. 11

**Heat exchanger**  
for refrigerant

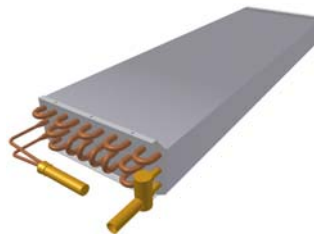

Fig. 12

**Heat exchanger**  
copper tubes with aluminum fins, max operating pressure 16 bar, coolant water, max. glycol ratio 50 %, water as heating medium, max. inlet temperature 90 °C, air vent and drain valves, optimized models for low heating, medium or high cooling medium temperatures and low-volume mass flow are available on request.

**Electric heater**  
230 V ~/N/PE 50 Hz/3 x 400 V~ 50/60 Hz

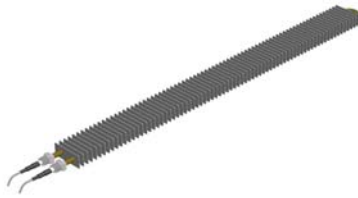

Fig. 13

**Centrifugal fan**  
230 V~ 50/60 Hz



Fig. 14

**Electric heater**  
with welded stainless steel fins, 2-stage heating capacity, 2 contactors, 2 safety temperature limiters

**Centrifugal fan**  
can be selected either with AC or highly efficient EC motors, with maintenance-free ball bearings, high pressure stability and long service life. Configuration and number of fans depend on unit size and selection

**Lateral wall /ceiling drain pan**



Fig. 15

**Lateral wall drain pan with humidity sensor for condensate pump**  
230 V ~ 50 Hz

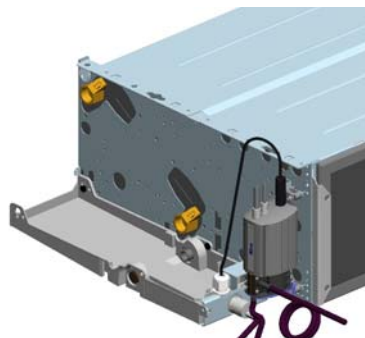

Fig. 16

**Lateral wall /ceiling drain pan**  
for collecting all condensate from heat exchanger and valve piping, for pressure-less condensate drainage, made of rigid plastic

**Lateral wall drain pan with humidity sensor fitted with condensate pump**  
For collecting condensate and drainage via condensate pump

**Filter element**



Fig. 17

**Mixed-air mechanism**



Fig. 18

**Filter element**  
easy to replace, available in G1, G2 and G3 (EN 779)

**Mixed-air mechanism\***  
with outside air intake connection made of galvanized metal sheet, condensate-insulated if temperature falls below dew point, aluminium mixing-air damper, cold air penetration guard via stable aluminium profile.

\*) The plant manufacturer / operator must operate the unit in accordance with EU Directive 1253.

**What are EC motors?**

EC-motors (= electronically commutated motors) are DC motors, where the rotor is not performed as a coil, like in usual AC motors (AC = alternating current), but consists of a permanent magnet. Electronic control of the motor enables continuous operation, where the integrated electronics ensures alternating magnetic field which adjusts itself to the relevant speed (refer to Fig. 19).

In such a way the motor operates at optimal conditions, resulting in maximum torque and minimum losses. The efficiency rate of the EC motors used by DencoHappel is twice as high as the comparable AC motors. The application of this technology in fan coil units makes it possible to achieve high efficiency rates for fan motors - especially in part-load mode.

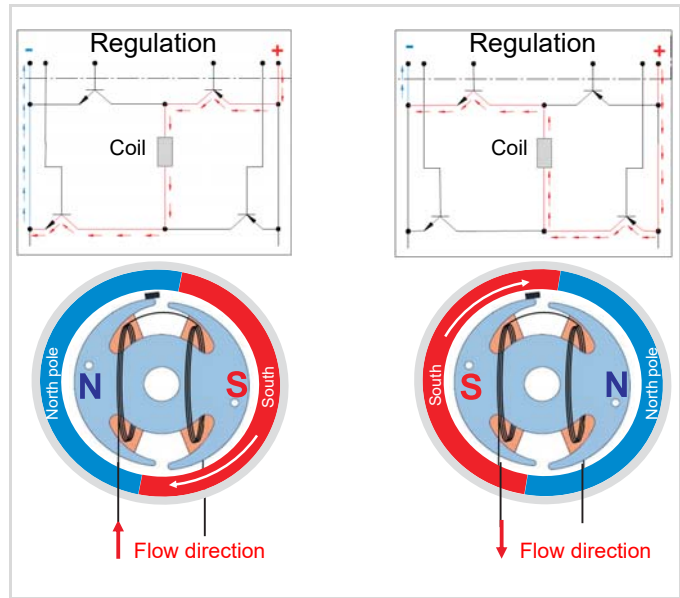

Fig. 19: Functional description of EC motor (electr. commutation)

This results in the reduction of electrical power consumption of an EC fan by up to 84%

**Comparison AC/EC fan - Flex-Geko**

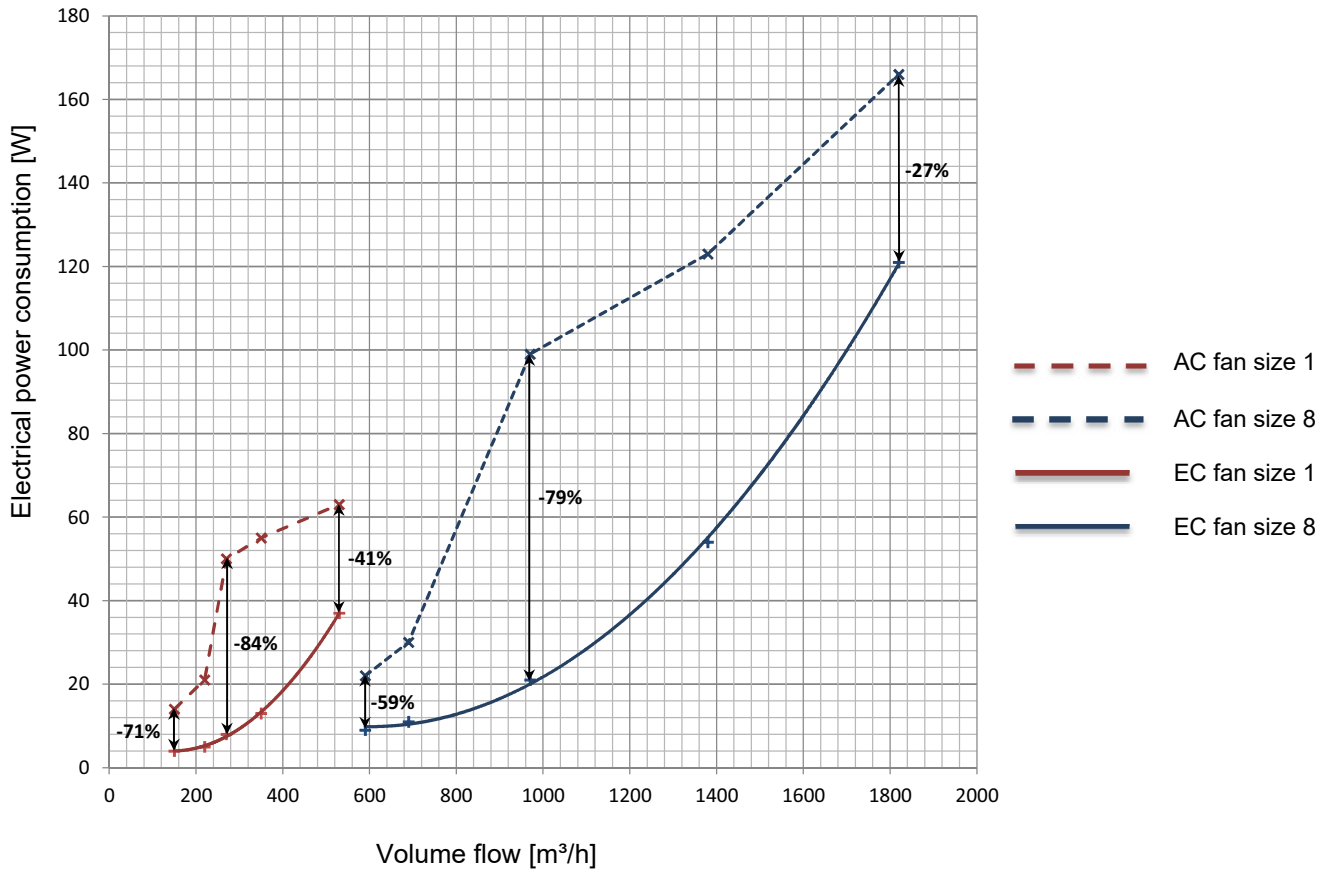

Fig. 20: Comparison - electrical power consumption EC/AC fan



- Further aspects:**
- Continuous operation
  - Low generation of heat
  - Established and usual high motor quality
  - Same design for 50 and 60 Hz

### Continuous fan controls (MATRIX and CET.ACEC)

EC fans featuring continuous operating mode offer a few of benefits:

- Room temperature control is performed with a higher accuracy, because occurring temperature differences can be addressed with the accordingly adjusted fan speed. This effect is assisted by using 3-point regulation valves (only with MATRIX control system).
- Variable fan speed control can compensate for fluctuating conditions of heating and cooling medium. Example: season-related different inlet temperature of heat generator or fluctuating volume flow rates (hydraulics)
- With standard AC fans the fan speed, which is optimal for room temperature control, must be adapted to the available fan speed stages which often leads to rapid increase of motor RPM and thus electrical power consumption.
- With continuous speed regulation - "hard" fan speed changes are eliminated, which provides additional acoustical comfort.

The MATRIX CET.ACEC controls uses these features by making the following functions available, the customer can select between automatic and manual operation:

**Automatic mode:** Room temperature control with continuous regulation (1.3-10 V) of a continuously variable EC fan. The fan continuously operates within the minimum and maximum air volumes.

Using the display control panel OP50/51 a speed limitation can be activated (mute function) in order to prevent an acoustic overshoot in automatic mode. This upper RPM limit can be separately set for each control panel (only MATRIX controls).

As an additional measure to avoid possible on-site acoustical resonance occurrences, up to three speed ranges can be hidden using only MATRIX.controls and service software.

**Manual mode  
MATRIX controls:** OP 50/51 (control panel with display): continuous fan setting using rotary switch between minimum and maximum air volume flow rate.

OP30/31 and OP44: (speed-stage control panel): 5-speed fan setting with speed 1 = minimum air volume flow rate and speed 5 = maximum air volume flow rate. Percentage values (regarding maximum air volume flow rate) for speeds 2-4 are pre-configured by the factory (default values) and can be changed on site by others using MATRIX.PC.

**Manual mode  
miniature switch  
CET.ACEC:** 3-stage fan control with  
stage 1 = min. air volume flow and  
stage 3 = max. air volume flow.

The control voltage (Volt) of stages 1-3 are preset by others (depending on selected unit) and can be changed on-site (with FläktGroup service tool or via MODbus interface).

## EUROVENT Energy Label

Within the framework of EU regulations (Eco-Design Directive) clear limits will be set in the future with respect to the energy efficiency of state-of-the-art technological standards. EUROVENT, as the European Association of Manufacturers of HVAC equipment, anticipates this development by having published Energy Label for fan coil units to include 5 energy efficiency classes (A to E) in January 2014.

In this case the energy efficiency is composed of time-weighted relationship between cooling or heating output and consumed electrical power of the fan.

If fan coil units are equipped with an energy-efficient temperature regulation system (MATRIX) the adjustment of fan speed is performed according to the situation-related heating or cooling demand. For the evaluation of energy efficiency - time percentage of the corresponding active speed stages must be considered. For the description of time-related conditions EUROVENT uses coefficient A (maximum), B (medium) and C (minimum speed). These indicators vary, depending on heating or cooling operating mode.

Fan stage	Coefficient	Time share	
		Cooling	Heating
High (maximum)	A	5 %	5 %
Medium	B	30 %	25 %
Low (minimum)	C	65 %	70 %

The energy efficiency relationship is composed of time-weighted shares and is presented in the example using the following formulas:

### Cooling (FCEER):

$$FCEER = \frac{A \times \dot{Q}_{KHighSpeed} + B \times \dot{Q}_{KMediumSpeed} + C \times \dot{Q}_{KLowSpeed}}{A \times Pe_{HighSpeed} + B \times Pe_{MediumSpeed} + C \times Pe_{LowSpeed}}$$

**Fan Coil Energy Efficiency Ratio - total cooling capacity**  
 (= Energy efficiency relationship)

### Heating (FCCOP):

$$FCCOP = \frac{A \times \dot{Q}_{HHighSpeed} + B \times \dot{Q}_{HMediumSpeed} + C \times \dot{Q}_{HLowSpeed}}{A \times Pe_{HighSpeed} + B \times Pe_{MediumSpeed} + C \times Pe_{LowSpeed}}$$

**Fan Coil Coefficient Of Performance**  
 (=Performance coefficient of fan coil unit)

with  $\dot{Q}_K$  = Total cooling capacity

with  $\dot{Q}_H$  = Heating capacity

with  $Pe$  = Electrical power consumption of fan

Higher numerical value of these indicators stands for especially outstanding energy efficiency.

For the corresponding energy label the EUROVENT determines the following classification:

Cooling FCEER (Total)			Heating FCCOP		
Class	>=	Value	Class	>=	Value
A	>=	185	A	>=	265
B	>=	120	B	>=	160
C	>=	80	C	>=	100
D	>=	55	D	>=	70
E	>=	40	E	>=	50

**Example:** Flex-Geko GF52.UWW1.SE0A1  
[unit code for 4-pipe with EC fan]

**Cooling (FCEER) \*:**

$$FCEER = \frac{5\% \times 4,58 + 30\% \times 3,53 + 65\% \times 2,72}{5\% \times 0,021 + 30\% \times 0,009 + 65\% \times 0,005} = 437 \geq 185 \xrightarrow{\text{Label}} \text{CLASS A}$$

**Heating (FCCOP) \*:**

$$FCCOP = \frac{5\% \times 4,53 + 25\% \times 3,62 + 70\% \times 2,91}{5\% \times 0,021 + 25\% \times 0,005 + 70\% \times 0,003} = 466 \geq 265 \xrightarrow{\text{Label}} \text{CLASS A}$$

\*) Cooling, heating and electrical output in [kW] under EUROVENT conditions:

Cooling: air intake 27°C / 47% r.h., chilled water 7 / 12°C

Heating: air intake 20°C, warm water 70 / 60°C

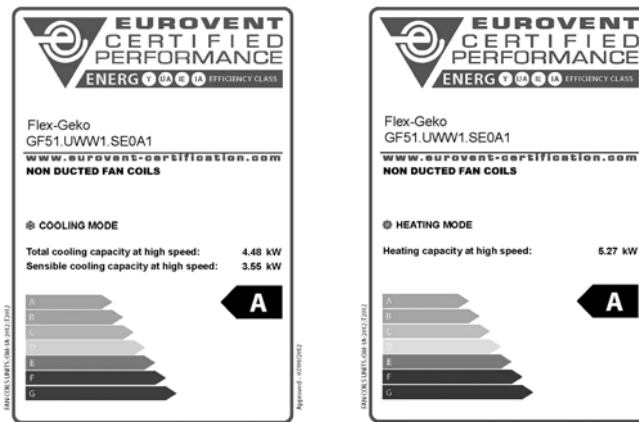

### Optimized heat exchangers for low-energy applications

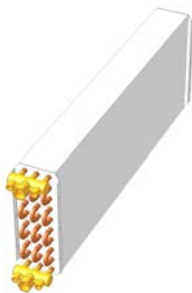

Flex-Geko offers today additional heat exchanger models especially for low-energy applications, such as heat pumps that are optimized for low heating medium or high cooling medium temperatures and low mass flows:

- 2-pipe system: additional capacity stage 4 \*
- 4-pipe system: additional capacity stage 3 \*

\*) Only unit models for water, without direct evaporator and/or electric heater

**AiD@** Data for all unit types can be calculated using our AiD@ layout software or provided by our sales representatives.

# Recirculating-Air Unit Heating and Cooling

## 4-pipe chilled and warm water

CWP 6/12 °C    PWW 70/50 °C  
 $t_{L1} = +27 °C$      $t_{L1} = +20 °C$   
 $\phi_1 = 46 \% \text{ r.h.}$

Flex-Geko

Sizes 1 to 8

Model size	Speeds	Air volume m <sup>3</sup> /h	Capacity stage 1				Capacity stage 2				AC-motor		EC motor	
			Cooling capacity $\dot{Q}_K$ kW	Pressure drop $\Delta p_K$ kPa	Heating capacity $\dot{Q}_H$ kW	Pressure drop $\Delta p_H$ kPa	Cooling capacity $\dot{Q}_K$ kW	Pressure drop $\Delta p_K$ kPa	Heating capacity $\dot{Q}_H$ kW	Pressure drop $\Delta p_H$ kPa	Sound power dB(A)	Sound pressure* dB(A)	Sound power dB(A)	Sound pressure* dB(A)
1	1	145	0.9	6.3	0.6	0.1	1.0	1.3	0.8	0.1	30	21	28	< 20
	2	215	1.2	10.0	0.9	0.1	1.3	2.3	1.0	0.2	36	28	37	28
	3	270	1.4	13.0	1.0	0.2	1.5	3.1	1.2	0.3	42	33	42	33
	4	345	1.6	16.6	1.1	0.2	1.8	4.4	1.4	0.4	48	39	48	39
	5	525	2.0	24.5	1.4	0.4	2.3	6.8	1.7	0.5	58	50	58	50
2	1	155	1.0	1.9	1.0	0.2	1.2	2.5	1.0	0.3	28	< 20	27	< 20
	2	225	1.3	3.2	1.2	0.4	1.6	4.2	1.3	0.4	35	26	36	27
	3	280	1.6	4.3	1.4	0.5	1.9	5.7	1.5	0.6	42	33	41	32
	4	355	1.8	5.6	1.6	0.6	2.3	8.1	1.8	0.8	46	37	47	38
	5	535	2.3	8.7	2.0	0.9	3.0	13.2	2.2	1.1	58	49	58	49
3	1	275	1.8	6.5	1.7	0.8	1.9	2.5	1.7	0.9	30	21	30	22
	2	345	2.1	8.7	1.9	1.0	2.2	3.4	2.0	1.1	35	27	36	27
	3	465	2.5	12.2	2.2	1.3	2.9	5.4	2.4	1.6	43	34	43	34
	4	665	3.1	17.6	2.7	1.8	3.6	8.3	2.9	2.2	52	44	52	43
	5	880	3.5	22.9	3.1	2.3	4.3	11.4	3.3	2.9	59	51	59	50
4	1	285	2.0	9.2	1.9	1.2	2.2	3.7	2.0	1.3	29	20	29	20
	2	355	2.3	12.4	2.2	1.5	2.6	5.0	2.2	1.7	35	26	34	25
	3	485	2.9	18.1	2.6	2.1	3.3	7.8	2.7	2.4	41	32	41	33
	4	715	3.6	27.5	3.2	3.0	4.3	13.0	3.4	3.6	51	42	51	42
	5	980	4.3	37.2	3.7	3.9	5.2	18.6	4.0	4.8	58	50	59	50
5	1	295	2.0	3.8	2.1	1.7	2.4	4.9	2.1	1.8	28	20	28	<20
	2	365	2.4	5.2	2.4	2.1	2.8	6.7	2.5	2.3	34	25	33	24
	3	515	3.0	7.9	3.0	3.0	3.7	11.0	3.1	3.5	42	34	41	33
	4	735	3.8	11.9	3.6	4.3	4.8	17.7	3.8	5.0	51	42	51	42
	5	1000	4.5	16.2	4.2	5.7	5.8	25.4	4.5	6.8	59	51	59	51
6	1	425	2.8	7.7	2.9	3.2	2.7	1.2	2.7	0.7	33	24	33	24
	2	555	3.4	11.0	3.4	4.3	3.5	1.8	3.1	0.9	39	31	40	31
	3	745	4.1	15.4	4.0	5.7	4.4	2.9	3.8	1.3	46	38	47	38
	4	980	4.8	20.5	4.6	7.5	5.4	4.1	4.4	1.8	55	47	54	46
	5	1295	5.7	27.2	5.3	9.5	6.4	5.7	5.1	2.3	62	54	62	53
7	1	455	3.2	10.2	3.2	4.4	3.1	1.6	3.0	0.9	33	24	33	24
	2	575	3.8	14.1	3.7	5.6	3.8	2.4	3.5	1.2	38	30	39	30
	3	765	4.5	19.8	4.3	7.4	4.9	3.8	4.1	1.7	46	38	46	37
	4	1020	5.4	26.9	5.1	9.9	6.0	5.4	4.9	2.3	54	45	54	45
	5	1405	6.4	36.8	5.9	13.0	7.4	8.0	5.8	3.1	62	53	62	54
8	1	575	3.9	16.5	3.9	6.8	4.0	2.8	3.6	1.4	34	25	34	25
	2	680	4.4	20.6	4.3	8.1	4.6	3.6	4.0	1.7	38	29	38	29
	3	955	5.4	30.0	5.2	11.4	6.0	5.9	5.0	2.5	46	37	46	37
	4	1365	-	-	6.3	16.0	7.6	9.1	6.0	3.6	55	46	55	46
	5	1800	-	-	7.2	20.1	9.1	12.6	7.0	4.8	61	53	62	53

Motor design		
AC motor	TC integr.	0
	TC led out	1
EC motor		E

Plastic terminal box (select sheet steel electric control box with MATRIX)



Speed combination

1-2-3 <sup>+</sup>	A
2-3-4 <sup>+</sup>	B
3-4-5 <sup>+</sup>	C
1-3-5 <sup>+</sup>	E
1-2-3-4-5 <sup>+</sup>	H
Min..Max (EC motor)	F

Metal-sheet electric control box with terminal block or for integrated controls



Speed combination

1-2-3 <sup>+</sup>	K
2-3-4 <sup>+</sup>	L
3-4-5 <sup>+</sup>	M
1-3-5 <sup>+</sup>	O
1-2-3-4-5 <sup>+</sup>	R
Min..Max (EC motor)	S

Data for capacity stage 3 (CS 3) are available on request (see Page 11).

1	Left	Wall	Medium connect.***
2	Right		
3	Left	Ceiling	
4	Right		
0	With drainage	Condensate line	
1	With condensate pump		
A	Circulating air ↻↻ supply air ↻↻		Air flow +++
B	Circulating air ↻↻ supply air ↻↻**		
C	Circulating air ↻↻ - supply air ↻↻		
D	Circulating air ↻↻ - supply air ↻↻**		
1	G1 mat filter		Filter
2	G2 mat filter		
3	G3 mat filter		

Order code

G F . U W W . . . . .

\* Ambient conditions see Page 70 Acoustics  
 \*\* Only wall units  
 \*\*\* Front connection side, facing discharge  
 + only AC motor  
 ++ Air volume flow CS 1 and filter class G1  
 \*\*\* Definition of air flow wall/ceiling see Page 74 Fig. 28

Accessories					Variant		Type	Code	
	Vertical wall/horizontal ceiling	A	Plastic adjustable	C		Discharge plenum primary air connection DN100	insulated	A	022
			Aluminium rigid	C				A	042
	Vertical wall	B	Plastic adjustable	C		Discharge bend	insulated	A	062
	Vertical wall/horizontal ceiling	C	Plastic adjustable	C		Flexible canvas discharge connector		A	112
			Aluminium rigid	C				A	212
	Vertical wall	D	Plastic adjustable	C		Geko-Drive – motorized regulated discharge profile ***	Left	A	412
							Right	A	422
	Vertical wall/horizontal ceiling; with unit foot cover **	A	Plastic adjustable	C		Air intake plenum with primary air connection DN 125	not insulated	A	011
			Aluminium rigid	C				A	031
	Vertical wall; with unit foot cover **	B	Plastic adjustable	C		Air intake bend	not insulated	A	051
	Vertical wall/horizontal ceiling; with unit foot cover and intake front grille **	A	Plastic adjustable	C		Intake flexible connection (transition piece required)		A	111
			Aluminium rigid	C				A	131
	Vertical wall, with unit foot cover and intake front grille **	B	Plastic adjustable	C		Transition piece for intake flexible connection, telescopic and sound-attenuator connection		A	151
	Horizontal ceiling; closed rear side	C	Plastic adjustable	C		Intake telescopic connection (transition piece required)	not insulated	A	211
			Aluminium rigid	C				A	713
	Vertical stand-alone installation closed on rear side	C	Plastic adjustable	C		Seal cap for round fitting, DN 200 *	insulated	A	913
			Aluminium rigid	C				A	813
						Unit feet for recirculating-air units *	G1	A	823
							G2	A	833
							G3	A	833

\*\* Unit feet ZGF.0A913 required

Sizes 1 to 8  
 \* 0, if irrespective of size

Order code



\*\*\* Note!  
 Geko-Drive only together with unit casing!

Valves

MATRIX 2000	MATRIX 3000/4000	Terminal box	Drive	Operating voltage/circuit	
•	•	•	2-point open/close	230 V AC <sup>2)</sup>	T
•	•	•	2-point open/close	24 V AC <sup>1), 2)</sup>	Q
	•	•	3-point open/stop/close	230 V AC	R
	•	•	3-point open/stop/close	24 V AC <sup>1)</sup>	N
		•	3-point open/stop/close	230 V AC + 2 contacts	C
		•	Continuous	0/2 ... 10 V = 24 V AC <sup>1)</sup>	S

1) 24 V-transformer to be provided by others

2)  $k_{vs}$ -values for open/close actuators (T,Q) only  $k_{vs}$  1.6 and 2.5 possible

Connection/shut-off	
Inlet/outlet flow with outside thread	0
Inlet/outlet with solder fitting	1
Inlet/outlet + ball trap with external thread	2
Inlet/outlet + ball trap with solder fitting	3
Inlet + ball trap/outlet + shut-off valve with external thread	4
Inlet + ball trap/outlet + shut-off valve with solder fitting	5

Medium connection	
Left	L
Right	R

$k_{vs}$ values		
Cooling/Heating		
0.25	≡	03
0.40	≡	04
0.63	≡	06
1.00	≡	10
1.60 <sup>2)</sup>	≡	16
2.50 <sup>2)</sup>	≡	25
4.00	≡	40

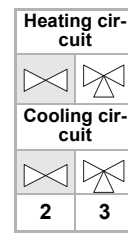

Order code



### FläktGroup MATRIX 2000

#### System features MATRIX 2000:

- Temperature assignment: 7...40 °C (default 10 ... 30 °C)
- Manual assignment of speed stage
- Adjustable regulating range
- Change-over between normal/economy mode on control panel
- Room temperature measurement using control panel
- External room temperature sensor can be connected
- Valve control (2-point)
- Temperature control via fan on/off and valve(s)
- Status messages using LED
- Group control
- Group switch-off switch-off in case of fault
- Motor temperature monitoring (TC required)
- Network-enabled

### MATRIX OP21C

Control panel for MATRIX 2000:

- Speed stage selection switch 0-A(Auto)-1-2-3
- Pure white casing, protection type IP20
- Economy mode button
- LEDs for operation/fault/ext.control
- Integrated room temperature sensor

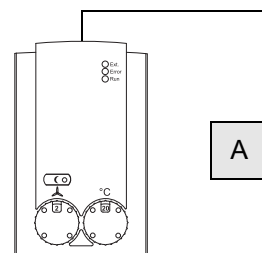

### FläktGroup MATRIX 3000/4000

#### System features MATRIX 3000:

- Temperature assignment.: 7...40 °C (default 10...30 °C)
- Speed (stage) assignment
- Adjustable regulating range
- Change-over between normal/economy mode on control panel
- Input for change-over between normal/economy mode or unit OFF with frost protection
- Room temperature measurement using control panel
- External room temperature sensor can be connected
- Valve control (2x2 or 2x3 point)
- Temperature control via fan and/or valve(s)
- Room frost protection
- Status messages using LED
- Status and fault signals using floating change-over contacts
- Unit individual and group control
- Isolation of individual units in case of fault
- Motor temperature monitoring (with speed stage motors TC required)
- Network-enabled

#### Additional features MATRIX 4000:

- Summer / winter compensation
- Noiseless valve control
- Cool and/or heat request via volt-free contacts (related to water circuit)
- Stand alone unit control
- Inputs for operating mode:
  - Normal mode
  - Economy mode
  - Autonomous mode
  - Unit OFF

### MATRIX OP30C

Control panel for MATRIX 3000/4000

- Pure white casing, protection type IP20
- Setpoint temperature setting
- Speed-stage selection switch 0-A(Auto)-1-2-3-4-5 (depends on motor type, with EC motor up to 5 stages)
- LEDs for operation/fault/ext.control
- Integrated room temperature sensor

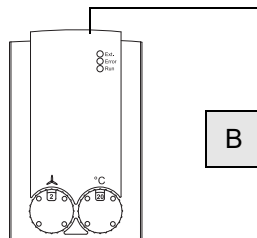

### MATRIX OP31C

As for control panel OP30C, but also with:

- Normal/economy mode buttons

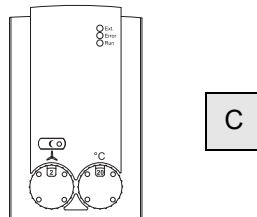

### MATRIX OP44C

As for control panel OP31C, but also with button for:

- Changeover between recirculating-air/ mixed-air operation
- Change-over heating/cooling/automatic mode

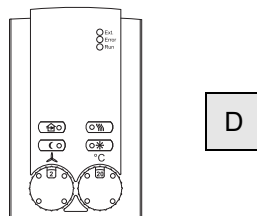

### MATRIX OP50C

Control panel for MATRIX 3000/4000

- Pure white casing, protection type IP20
- Menu-guided controls using rotation navigator
- LCD display with plain-text display
- Status messages using pictograms
- Integrated room temperature sensor
- Continuous speed regulation (only together with EC motor)

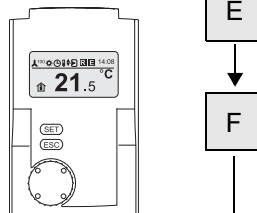

### MATRIX OP51C

As for control panel OP50C, but also with:

- Integrated weekly clock timer with a holiday and special days programme

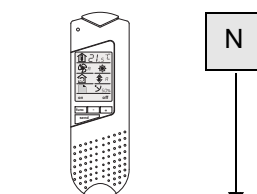

### MATRIX.IR

Infrared remote control for control system MATRIX 3000/4000

- Black casing, RAL 9004
- LCD display approx. 45x30 mm
- Function as in OP44C (without status, fault and external control signals, no integrated room temperature sensor)
- Maximum range 20 m
- Speed-stage selection switch 0-A(Auto)-1-2-3-4-5 (depends on motor type, with EC motor up to 5 stages)



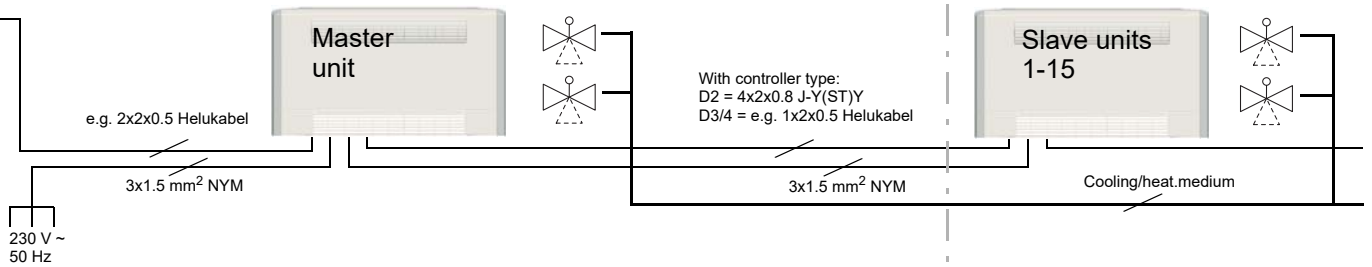
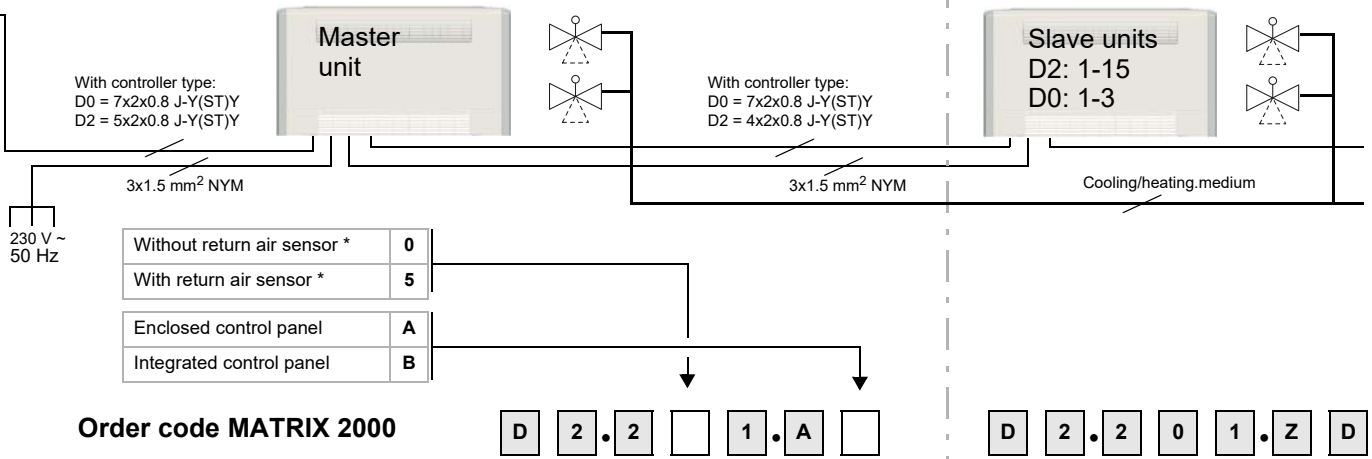

Speed (EC motor)	Speed stages (AC motor)	Stand alone unit control with operating and Fault signal	Group regulation with status and alarm signals	Input unit OFF with room frost protection	Input economy contact	Supply temperature limitation	Noiseless valve control	Contact heat and cool request	Geko-Drive	Connection external sensor			
											3	1	
Continuous	up to 3 speed		•	•							3	1	
			•		•							3	2
		•										3	1
		•										3	2
		•										3	3
		•										3	4
		•							•		•	4	1
		•							•		•	4	2
	up to 5 speed											4	3
												4	4
		•										4	5
		•										4	6
		•										4	6
		•										4	6
		•										4	6
		•										4	6

2	0	1
2	0	1
3		1
3		2
3		3
3		4
4		1
4		2
4		3
4		4
4		4
4		5
4		6
4		6
4		6

- Without return air sensor \* 0
- With return air sensor \* 5
- Control panel
- Enclosed control panel A
- Integrated control panel B

**Order code**

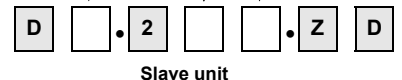
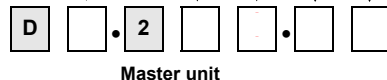

\* Alternative room temperature sensor (see Page 99)

# Recirculating-Air Unit Heating and Cooling

## 2-pipe chilled water and electric heating

CWP 6/12 °C  
 t<sub>L1</sub> = +27 °C  
 φ<sub>1</sub> = 46 % r.h.

Electric heater  
 230V~N/P/E  
 50Hz

Flex-Geko

Sizes 1 to 8

Model size	Speeds	Air volume m <sup>3</sup> /h	Capacity stage 1				Capacity stage 2				Capacity stage 3				AC motor		EC motor	
			Q <sub>K</sub> • Cooling capacity kW	Pressure drop Δp <sub>K</sub> kPa	Q <sub>H</sub> • AEX Speed L kW	Q <sub>H</sub> • AEX Speed M kW	Q <sub>K</sub> • Cooling capacity kW	Pressure drop Δp <sub>K</sub> kPa	Q <sub>H</sub> • AEX Speed L kW	Q <sub>H</sub> • AEX Speed M kW	Q <sub>K</sub> • Cooling capacity kW	Pressure drop Δp <sub>K</sub> kPa	Q <sub>H</sub> • AEX Speed L kW	Q <sub>H</sub> • AEX Speed M kW	Sound power dB(A)	Sound pressure * dB(A)	Sound power dB(A)	Sound pressure * dB(A)
1	2	220	1.2	9.2	0.87	-	1.4	3.4	0.87	-	1.6	4.1	0.87	-	36	28	37	28
1	3	270	1.4	11.4	0.87	0.87	1.7	4.6	0.87	0.87	1.9	5.5	0.87	0.87	42	33	42	33
1	4	350	1.6	14.9	1.74	0.87	1.9	6.2	1.74	0.87	2.3	8.1	1.74	0.87	48	39	48	39
1	5	530	2.0	21.9	-	1.74	2.5	9.9	-	1.74	3.0	13.0	-	1.74	58	50	58	50
2	1	-	-	-	-	-	-	-	-	-	-	-	-	-	-	-	-	-
2	2	230	1.5	17.7	1.27	-	1.7	6.2	1.27	-	1.7	1.7	1.27	-	35	26	36	27
2	3	280	1.7	22.1	1.27	1.27	2.0	8.3	1.27	1.27	2.0	2.5	1.27	1.27	42	33	41	32
2	4	360	2.0	29.1	2.54	1.27	2.4	11.1	2.54	1.27	2.5	3.7	2.54	1.27	46	37	47	38
2	5	540	-	-	-	2.54	3.1	18.4	-	2.54	3.4	6.4	-	2.54	58	49	58	49
3	1	-	-	-	-	-	-	-	-	-	-	-	-	-	-	-	-	-
3	2	350	2.0	7.2	1.67	-	2.5	4.9	1.67	-	2.7	4.9	1.67	-	35	27	36	27
3	3	470	2.4	10.0	1.67	1.67	3.1	7.4	1.67	1.67	3.4	7.6	1.67	1.67	43	34	43	34
3	4	670	3.0	14.7	3.34	1.67	3.9	11.2	3.34	1.67	4.4	12.2	3.34	1.67	52	44	52	43
3	5	890	3.4	19.1	-	3.34	4.5	15.1	-	3.34	5.3	17.5	-	3.34	59	51	59	50
4	1	-	-	-	-	-	-	-	-	-	-	-	-	-	-	-	-	-
4	2	360	2.3	10.4	1.95	-	2.8	6.9	1.95	-	2.9	3.7	1.95	-	35	26	34	25
4	3	490	2.8	15.0	1.95	1.95	3.5	10.5	1.95	1.95	3.7	5.9	1.95	1.95	41	32	41	32
4	4	720	3.5	22.6	3.90	1.95	4.5	17.2	3.90	1.95	5.0	10.0	3.90	1.95	51	42	51	42
4	5	990	4.1	30.8	-	3.90	5.5	24.4	-	3.90	6.2	15.1	-	3.90	58	50	59	50
5	1	-	-	-	-	-	-	-	-	-	-	-	-	-	-	-	-	-
5	2	370	2.5	13.9	2.03	-	3.0	9.3	2.03	-	3.1	4.9	2.03	-	34	25	33	24
5	3	520	3.2	21.3	2.03	2.03	3.9	14.7	2.03	2.03	4.2	8.2	2.03	2.03	42	34	41	33
5	4	740	3.9	31.5	4.06	2.03	5.0	23.0	4.06	2.03	5.4	13.3	4.06	2.03	51	42	51	42
5	5	1010	4.7	43.0	-	4.06	6.1	33.4	-	4.06	6.7	19.5	-	4.06	59	51	59	51
6	1	-	-	-	-	-	-	-	-	-	-	-	-	-	-	-	-	-
6	2	560	3.1	3.9	2.07	-	3.8	2.6	2.07	-	3.7	1.2	2.07	-	39	31	40	31
6	3	750	3.8	5.4	2.07	2.07	4.8	4.0	2.07	2.07	5.0	2.1	2.07	2.07	46	38	47	38
6	4	990	4.4	7.3	4.14	2.07	5.7	5.6	4.14	2.07	6.3	3.2	4.14	2.07	55	47	54	46
6	5	1310	5.2	9.8	-	4.14	6.8	7.6	-	4.14	7.6	4.5	-	4.14	62	54	62	53
7	1	-	-	-	-	-	-	-	-	-	-	-	-	-	-	-	-	-
7	2	580	3.5	5.0	2.07	-	4.2	3.4	2.07	-	4.3	1.7	2.07	-	38	30	39	30
7	3	770	4.2	7.1	2.07	2.07	5.2	5.0	2.07	2.07	5.5	2.7	2.07	2.07	46	38	46	37
7	4	1030	5.0	9.8	4.14	2.07	6.4	7.3	4.14	2.07	6.8	4.1	4.14	2.07	54	45	54	45
7	5	1420	5.9	13.4	-	4.14	7.8	10.6	-	4.14	8.7	6.3	-	4.14	62	53	62	54
8	1	-	-	-	-	-	-	-	-	-	-	-	-	-	-	-	-	-
8	2	690	4.2	7.7	2.07	-	5.0	5.1	2.07	-	5.2	2.7	2.07	-	38	29	38	29
8	3	970	5.2	11.3	2.07	2.07	6.4	7.9	2.07	2.07	6.8	4.4	2.07	2.07	46	37	46	37
8	4	1380	6.3	16.3	4.14	2.07	8.2	12.6	4.14	2.07	8.9	7.1	4.14	2.07	55	46	54	46
8	5	1820	7.3	21.1	-	4.14	9.6	16.9	-	4.14	10.8	10.1	-	4.14	61	53	61	53

Motor design		
AC motor	TC integr.	0
	TC led out	1
EC motor		E

Metal sheet electric control box with terminal strip or for integ. Controls



Speed combination

2-3-4	L
3-4-5	M
Min..Max (EC motor)	S

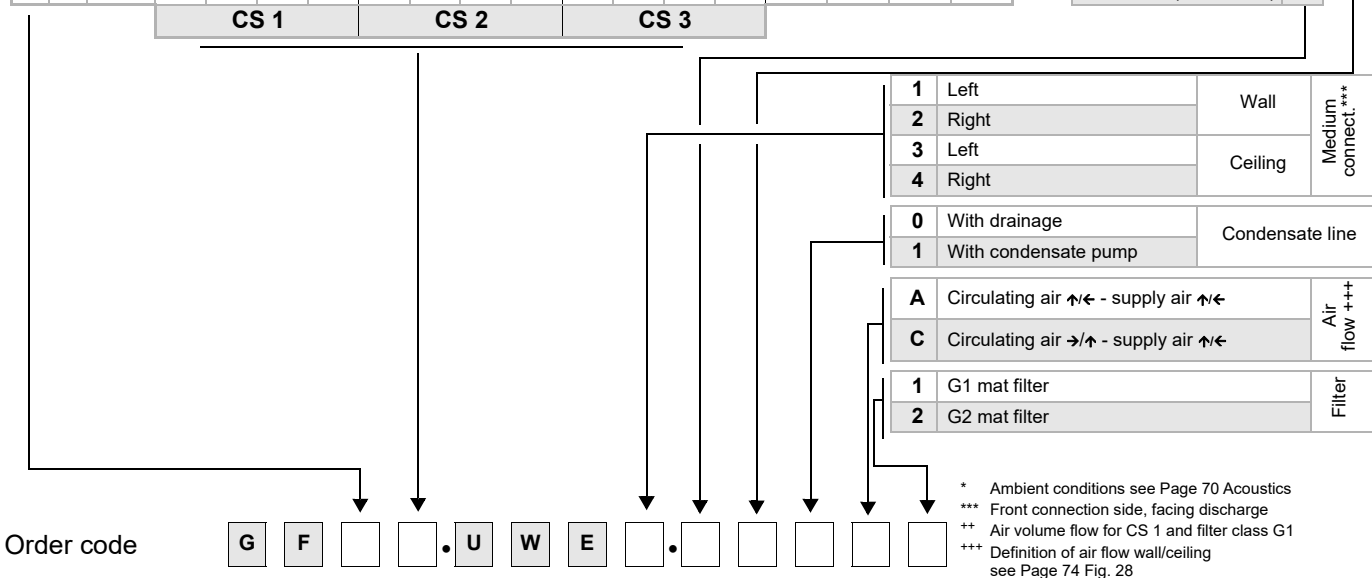





**FläktGroup MATRIX 2000**  
not applicable

**FläktGroup MATRIX 4000**

**System features MATRIX 4000:**

- Temperature assignment.: 7...40 °C (default 10..30 °C)
- Assignment of speed stage
- Adjustable regulating range
- Change-over between normal/economy mode on control panel
- Input for change-over between normal/economy mode or unit OFF with frost protection
- Room temperature measurement using control panel
- External room temperature sensor can be connected
- Valve control (2 or 3 point)
- Temperature control via fan and/or valve
- Room frost protection
- Status messages using LED
- Status and alarm signal via volt free change-over contacts
- Unit individual and group control
- Isolation of individual units in case of fault
- Motor temperature monitoring (with speed stage motors TC required)
- Network-enabled
- Summer / winter compensation
- Noiseless valve control
- Cool request via volt free contact (related to water circuit)
- Stand alone unit control
- Inputs for operating mode:
  - Normal mode
  - Economy mode
  - Autonomous mode
  - Unit OFF
- Regulation of multi-stage electrical heating with disconnection in case of over-temperature

**MATRIX OP30C**

Control panel for MATRIX 4000

- Pure white casing, protection type IP20
- Setpoint temperature setting
- Speed-stage selection switch 0-A(Auto)-1-2-3-4-5 (depends on motor type, with EC motor up to 5 stages)
- LEDs for operation/fault/ext.control
- Integrated room temperature sensor

**MATRIX OP31C**

As for control panel OP30C, but also with:

- Normal/economy mode buttons

**MATRIX OP44C**

As for control panel OP31C, but also with button for:

- Changeover between recirculating-air/mixed-air operation
- Change-over heating/cooling/automatic mode

**MATRIX OP50C**

Control panel for MATRIX 4000

- Pure white casing, protection type IP20
- Menu-guided controls using rotation navigator
- LCD display with plain-text display
- Status messages using pictograms
- Integrated room temperature sensor

**MATRIX OP51C**

As for control panel OP50C, but also with:

- Integrated weekly clock timer with holiday and special days programme

**MATRIX.IR**

Infrared remote control for control system MATRIX 4000

- Black casing, RAL 9004
- LCD display approx. 45x30 mm
- Function as in OP44C (without status, alarm and external control signals, no integrated room temperature sensor)
- Maximum range 20 m
- Speed-stage selection switch 0-A(Auto)-1-2-3-4-5 (depends on motor type, with EC motor up to 5 stages)

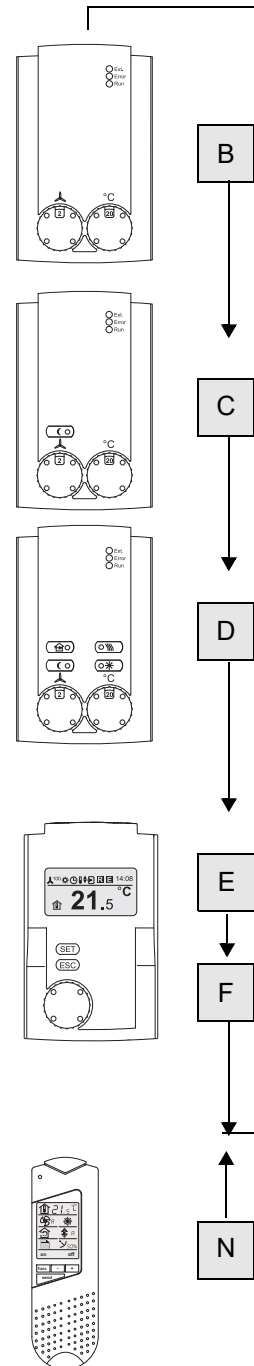

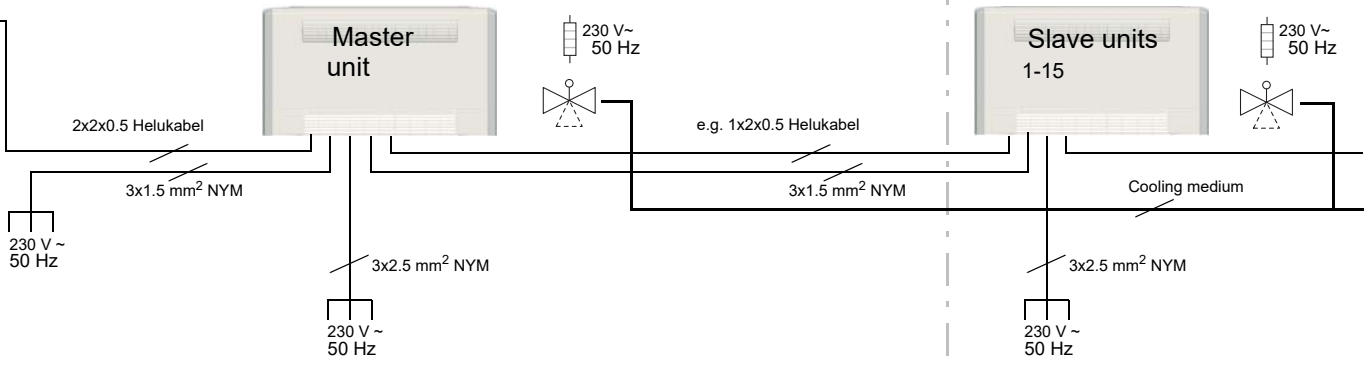

Speed (EC motor)	Speeds	Stand alone unit control with operating and Fault signal	Input unit OFF with room frost protection	Input economy contact	Noiseless valve control	Contact heat and cool request	Connection external sensor	
Continuous	up to 3 speed	•	•		•		•	1
		•		•	•		•	2
		•	•	•	•	•	•	5

Without return air sensor *	2
With return air sensor *	7
Control panel	
Enclosed control panel	A
Integrated control panel	B

**Order code**

D 4 . 2 [ ] [ ] . [ ] [ ]

Master unit

1  
2  
5

D 4 . 2 [ ] [ ] . Z D

Slave unit

\* Alternatively room temperature sensor (see Page 99)

# Recirculating-Air Unit Heating and Cooling

## Direct evaporator and 2-pipe warm water

Flex-Geko

Sizes 1 to 8

Refrigerant: R410A  
 t<sub>o</sub> = 10 °C  
 t<sub>L1</sub> = +27 °C  
 φ<sub>1</sub> = 46 % r.h.  
 PWW 70/50 °C  
 t<sub>L1</sub> = +20 °C

Model size	Speeds	Air volume m <sup>3</sup> /h	Capacity stage 1			AC motor		EC motor	
			Q <sub>K</sub> Cooling capacity kW	Q <sub>H</sub> Heating capacity kW	Pressure drop Δp <sub>H</sub> kPa	Sound power dB(A)	Sound pressure* dB(A)	Sound power dB(A)	Sound pressure* dB(A)
1	1	-	-	-	-	-	-	-	-
	2	-	-	-	-	-	-	-	-
	3	270	1.0	1.0	0.2	42	34	41	32
	4	345	1.1	1.1	0.2	48	39	47	39
	5	525	1.3	1.4	0.4	59	51	57	49
2	1	-	-	-	-	-	-	-	-
	2	-	-	-	-	-	-	-	-
	3	280	1.1	1.4	0.5	42	34	40	32
	4	355	1.3	1.6	0.6	47	38	46	38
	5	535	1.6	2.0	0.9	60	51	57	48
3	1	-	-	-	-	-	-	-	-
	2	-	-	-	-	-	-	-	-
	3	465	1.8	2.2	1.3	43	34	43	34
	4	665	2.2	2.7	1.8	53	44	52	43
	5	880	2.6	3.1	2.3	60	51	59	50
4	1	-	-	-	-	-	-	-	-
	2	-	-	-	-	-	-	-	-
	3	485	1.9	2.6	2.1	41	32	41	32
	4	715	2.4	3.2	3.0	50	42	50	41
	5	980	2.7	3.7	3.9	58	50	58	50
5	1	-	-	-	-	-	-	-	-
	2	-	-	-	-	-	-	-	-
	3	515	2.1	3.0	3.0	42	33	40	32
	4	735	2.6	3.6	4.3	51	43	50	41
	5	1000	3.0	4.2	5.7	59	51	59	50
6	1	-	-	-	-	-	-	-	-
	2	-	-	-	-	-	-	-	-
	3	745	2.8	4.0	5.7	47	38	46	37
	4	980	3.3	4.6	7.5	56	47	53	45
	5	1295	3.9	5.3	9.5	62	54	61	52
7	1	-	-	-	-	-	-	-	-
	2	-	-	-	-	-	-	-	-
	3	765	3.1	4.3	7.4	47	39	45	36
	4	1020	3.8	5.1	9.9	54	46	53	44
	5	1405	4.6	5.9	13.0	62	53	62	53
8	1	-	-	-	-	-	-	-	-
	2	-	-	-	-	-	-	-	-
	3	955	3.5	5.2	11.4	47	39	45	37
	4	1365	4.3	6.3	16.0	55	47	54	45
	5	1800	4.9	7.2	20.1	62	53	61	52

Motor design		
AC motor	TC integr.	0
	TC led out	1
EC motor		E

Metal sheet electric control box with terminal block or for integ. Controls



Speed combination

3-4-5	M
Min..Max (EC motor)	S

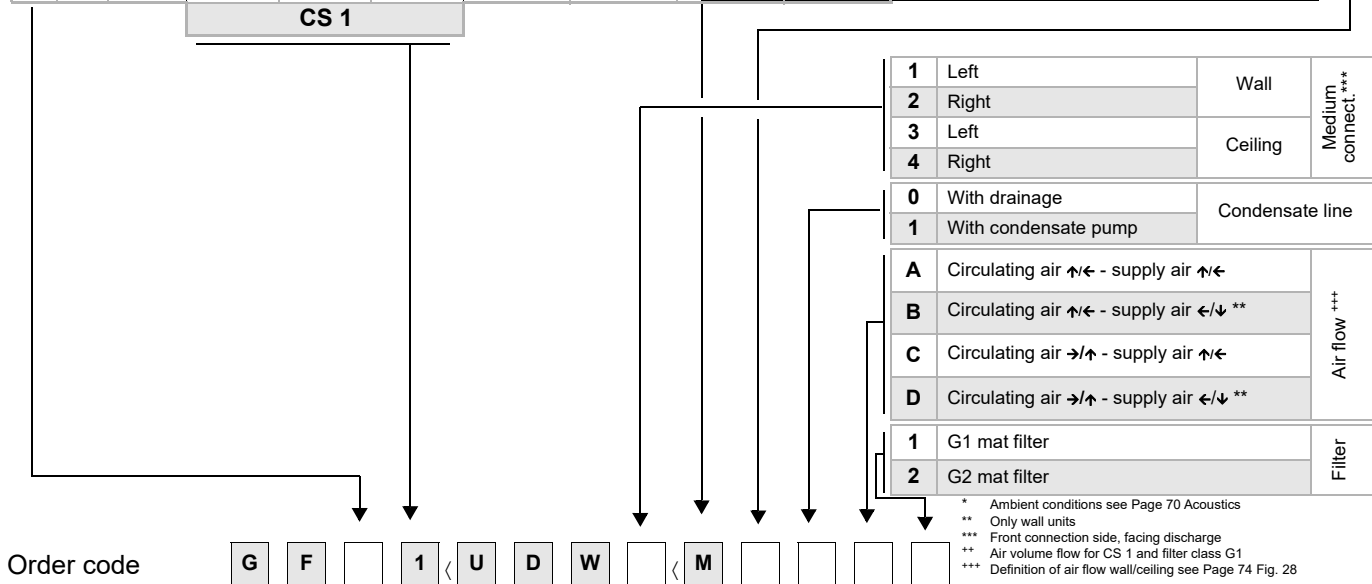

Order code

G F 1 U D W M



**FläktGroup MATRIX 2000**  
not applicable

**FläktGroup MATRIX 3000/4000**

**System features MATRIX 3000:**

- Temperature assignment.: 7...40 °C (default 10..30 °C)
- Speed (stage) assignment
- Adjustable regulating range
- Change-over between normal/economy mode on control panel
- Input for change-over between normal/economy mode or unit OFF with frost protection
- Room temperature measurement using control panel
- External room temperature sensor can be connected
- Valve control (2 or 3 point)
- Temperature control via fan and/or valve
- Room frost protection
- Status messages using LED
- Status and alarm signal via volt free change-over contacts
- Unit individual and group control
- Isolation of individual units in case of fault
- Motor temperature monitoring (with speed stage motors TC required)
- Network-enabled

**Additional features MATRIX 4000:**

- Summer / winter compensation
- Noiseless valve control
- Heat request via volt-free contact (related to water circuit)
- Stand alone unit control
- Inputs for operating mode:
  - Normal mode
  - Economy mode
  - Autonomous mode
  - Unit OFF

**MATRIX OP30C**

- Control panel for MATRIX 3000/4000
- Pure white casing, protection type IP20
  - Setpoint temperature setting
  - Speed-stage selection switch 0-A(Auto)-1-2-3-4-5 (depends on motor type, with EC motor up to 5 stages)
  - LEDs for operation/fault/ext.control
  - Integrated room temperature sensor

**MATRIX OP31C**

- As for control panel OP30C, but also with:
- Normal/economy mode buttons

**MATRIX OP44C**

- As for control panel OP31C, but also with button for:
- Changeover between recirculating-air/ mixed-air operation
  - Change-over heating/cooling/automatic mode

**MATRIX OP50C**

- Control panel for MATRIX 3000/4000
- Pure white casing, protection type IP20
  - Menu-guided controls using rotation navigator
  - LCD display with plain-text display
  - Status messages using pictograms
  - Integrated room temperature sensor
  - Continuous speed regulation (only together with EC motor)

**MATRIX OP51C**

- As for control panel OP50C, but also with:
- Integrated weekly clock timer with holiday and special days programme

**MATRIX.IR**

- Infrared remote control for control system MATRIX 3000/4000
- Black casing, RAL 9004
  - LCD display approx. 45x30 mm
  - Function as in OP44C (without status, fault and external control signals, no integrated room temperature sensor)
  - Maximum range 20 m
  - Speed-stage selection switch 0-A(Auto)-1-2-3-4-5 (depends on motor type, with EC motor up to 5 stages)

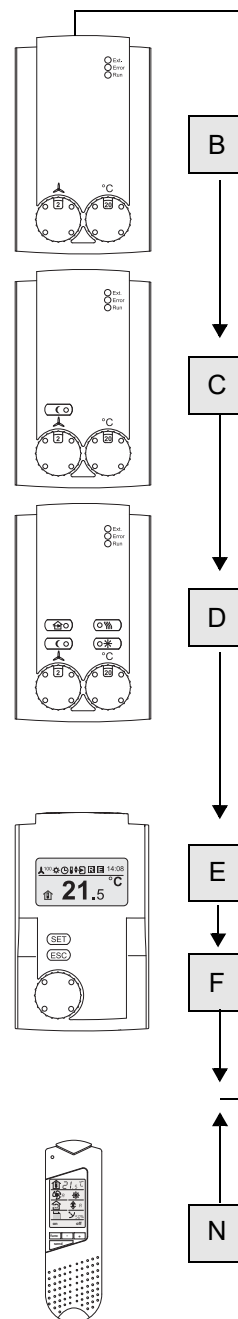

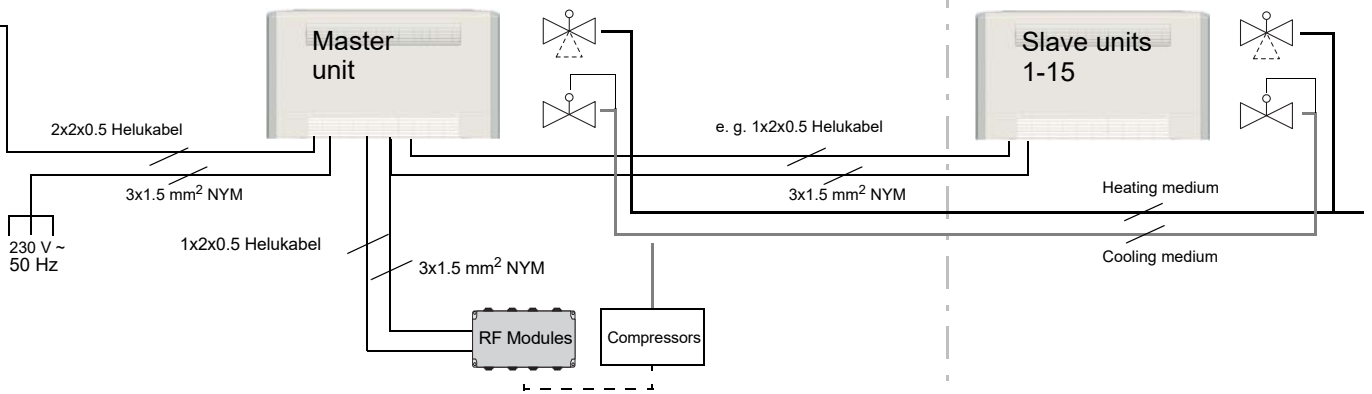

Speeds EC motor	Speed stages AC motor	Stand alone unit control with operating and Fault signal	Input unit OFF with room frost protection	Input economy contact	Noiseless valve control	Contact heat and cool request	Connection external sensor		
Continuous	up to 3 speed	•	•					3	1
		•		•				3	2
		•	•		•		•	4	1
		•		•	•	•	•	4	2
		•	•	•	•	•	•	4	3

3	1
3	2
4	1
4	2
4	3

Without return air sensor *	3
With return air sensor *	8
Control panel	
Enclosed control panel	A
Integrated control panel	B

**Order code**

D [ ] . 2 [ ] [ ] . [ ] [ ]

Master unit

D [ ] . 2 [ ] [ ] . Z D

Slave unit

\* Alternatively room temperature sensor (see Page 99)

# Recirculating-Air Unit Heating or Cooling

## 2-pipe chilled or warm water

Flex-Geko

Sizes 1 to 8

CWP 6/12 °C  
 $t_{L1} = +27$  °C  
 $\phi_1 = 46$  % r.h.

PWW 70/50 °C  
 $t_{L1} = +20$  °C

Model size	Speeds	Air volume m <sup>3</sup> /h	Capacity stage 1				Capacity stage 2				Capacity stage 3				AC-Motor		EC motor	
			Q <sub>K</sub> •Cooling capacity kW	Pressure drop Δp <sub>K</sub> kPa	Q <sub>H</sub> •Heating capacity kW	Pressure drop Δp <sub>H</sub> kPa	Q <sub>K</sub> •Cooling capacity kW	Pressure drop Δp <sub>K</sub> kPa	Q <sub>H</sub> •Heating capacity kW	Pressure drop Δp <sub>H</sub> kPa	Q <sub>K</sub> •Cooling capacity kW	Pressure drop Δp <sub>K</sub> kPa	Q <sub>H</sub> •Heating capacity kW	Pressure drop Δp <sub>H</sub> kPa	Sound power dB(A)	Sound pressure * dB(A)	Sound power dB(A)	Sound pressure * dB(A)
1	1	150	1.0	5.8	1.7	1.6	1.0	1.9	1.9	0.6	1.2	2.2	2.0	0.6	30	21	28	< 20
	2	220	1.2	9.2	2.3	2.6	1.4	3.4	2.6	1.0	1.6	4.1	2.9	1.1	36	28	37	28
	3	270	1.4	11.4	2.6	3.4	1.7	4.6	3.1	1.4	1.9	5.5	3.4	1.6	42	33	42	33
	4	350	1.6	14.9	3.1	4.6	1.9	6.2	3.7	1.9	2.3	8.1	4.2	2.3	48	39	48	39
	5	530	2.0	21.9	3.9	7.2	2.5	9.9	5.0	3.3	3.0	13.0	5.5	3.9	58	50	58	50
2	1	160	1.2	10.8	2.0	2.8	1.3	3.6	2.2	0.9	1.3	1.1	2.2	0.3	28	< 20	28	< 20
	2	230	1.5	17.7	2.6	4.5	1.7	6.2	3.0	1.6	1.7	1.7	3.1	0.5	35	26	36	27
	3	280	1.7	22.1	3.1	5.9	2.0	8.3	3.6	2.2	2.0	2.5	3.7	0.7	42	33	41	32
	4	360	2.0	29.1	3.6	8.1	2.4	11.1	4.3	3.2	2.5	3.7	4.6	1.1	46	37	47	38
	5	540	-	-	4.7	13.0	3.1	18.4	5.8	5.4	3.4	6.4	6.2	1.8	58	49	58	49
3	1	280	1.7	5.5	3.2	1.6	2.1	3.5	3.7	1.0	2.2	3.5	3.8	0.9	30	21	30	22
	2	350	2.0	7.2	3.7	2.1	2.5	4.9	4.5	1.4	2.7	4.9	4.6	1.3	35	27	36	27
	3	470	2.4	10.0	4.6	3.0	3.1	7.4	5.6	2.1	3.4	7.6	6.0	2.0	43	34	43	34
	4	670	3.0	14.7	5.8	4.7	3.9	11.2	7.2	3.3	4.4	12.2	7.9	3.4	52	44	52	43
	5	890	3.4	19.1	6.8	6.4	4.5	15.1	8.8	4.8	5.3	17.5	9.6	4.9	59	51	59	50
4	1	290	2.0	7.8	3.5	2.1	2.3	5.1	4.0	1.3	2.4	2.6	4.1	0.7	29	20	29	20
	2	360	2.3	10.4	4.1	2.9	2.8	6.9	4.8	1.8	2.9	3.7	5.0	0.9	35	26	34	25
	3	490	2.8	15.0	5.1	4.3	3.5	10.5	6.2	2.8	3.7	5.9	6.5	1.5	41	32	41	33
	4	720	3.5	22.6	6.6	6.8	4.5	17.2	8.2	4.8	5.0	10.0	8.9	2.7	51	42	51	42
	5	990	4.1	30.8	8.1	9.9	5.5	24.4	10.1	7.1	6.2	15.1	11.1	4.1	58	50	59	50
5	1	300	2.1	10.4	3.7	2.7	2.6	6.8	4.3	1.7	2.6	3.5	4.3	0.8	28	20	28	< 20
	2	370	2.5	13.9	4.4	3.7	3.0	9.3	5.1	2.3	3.1	4.9	5.2	1.2	34	25	33	24
	3	520	3.2	21.3	5.7	5.8	3.9	14.7	6.7	3.8	4.2	8.2	7.1	2.0	42	34	41	33
	4	740	3.9	31.5	7.2	9.0	5.0	23.0	8.9	6.3	5.4	13.3	9.4	3.4	51	42	51	42
	5	1010	4.7	43.0	8.8	13.0	6.1	33.4	11.0	9.2	6.7	19.5	12.0	5.3	59	51	59	51
6	1	430	2.6	2.7	4.9	0.8	3.0	1.7	5.7	0.5	3.1	0.9	5.7	0.3	33	24	33	24
	2	560	3.1	3.9	5.9	1.2	3.8	2.6	7.1	0.8	3.7	1.2	7.2	0.4	39	31	40	31
	3	750	3.8	5.4	7.3	1.7	4.8	4.0	8.8	1.2	5.0	2.1	9.4	0.6	46	38	47	38
	4	990	4.4	7.3	8.8	2.4	5.7	5.6	10.8	1.7	6.3	3.2	11.6	0.9	55	47	54	46
	5	1310	5.2	9.8	10.5	3.4	6.8	7.6	13.1	2.4	7.6	4.5	14.2	1.4	62	54	62	53
7	1	460	2.9	3.7	5.4	1.1	3.5	2.4	6.2	0.7	3.4	1.1	6.4	0.3	33	24	33	24
	2	580	3.5	5.0	6.4	1.5	4.2	3.4	7.5	0.9	4.3	1.7	7.8	0.5	38	30	39	30
	3	770	4.2	7.1	7.8	2.1	5.2	5.0	9.5	1.4	5.5	2.7	10.0	0.8	46	38	46	37
	4	1030	5.0	9.8	9.5	3.0	6.4	7.3	11.7	2.1	6.8	4.1	12.6	1.2	54	45	54	45
	5	1420	5.9	13.4	11.7	4.5	7.8	10.6	14.6	3.2	8.7	6.3	15.9	1.8	62	53	62	54
8	1	590	3.7	6.2	6.8	1.7	4.4	4.0	7.8	1.1	4.4	2.0	7.7	0.5	34	25	34	26
	2	690	4.2	7.7	7.6	2.2	5.0	5.1	8.9	1.4	5.2	2.7	9.2	0.7	38	29	38	29
	3	970	5.2	11.3	9.6	3.3	6.4	7.9	11.7	2.2	6.8	4.4	12.1	1.2	46	37	46	37
	4	1380	6.3	16.3	12.1	5.1	8.2	12.6	15.0	3.6	8.9	7.1	16.1	2.0	55	46	54	46
	5	1820	7.3	21.1	14.4	7.0	9.6	16.9	18.1	5.0	10.8	10.1	19.6	2.9	61	53	61	53

Motor design		
AC motor	TC integr.	0
	TC led out	1
EC motor		E

Plastic terminal box (with MATRIX metal sheet electrical control box)



Speed combination

1-2-3+	A
2-3-4+	B
3-4-5+	C
1-3-5+	E
1-2-3-4-5+	H
Min..Max (EC motor)	F

Metal sheet electric control box with terminal strip or for integ. Controls



Speed combination

1-2-3+	K
2-3-4+	L
3-4-5+	M
1-3-5+	O
1-2-3-4-5+	R
Min..Max (EC motor)	S

Data for capacity stage 4 (CS 4) are available on request (see Page 11).

1	Left	Wall	Medium connect.***
2	Right		
3	Left	Ceiling	Medium connect.***
4	Right		
0	With drainage	Condensate line	
1	With condensate pump		
A	Circulating air ↕↔ - supply air ↕↔	Air flow +++	
B	Circulating air ↕↔ - supply air ↔↕**		
C	Circulating air →↕ - supply air ↕↔		
D	Circulating air →↕ - supply air ↔↕**		
1	G1 mat filter	Filter	
2	G2 mat filter		
3	G2 mat filter		

Order code

G F . U W C . . . . .

\* Ambient conditions see Page 70 Acoustics  
 \*\* Only wall units  
 \*\*\* Front connection side, facing discharge  
 + only AC motor  
 ++ Air volume flow for CS 1 and filter class G1  
 \*\*\* Definition of air flow wall/ceiling see Page 74 Fig. 28



Accessories					Variant		Type	Code	
	Vertical wall/ horizontal ceiling	A	Plastic adjustable	C	012		Discharge plenum primary air connection DN100	insulated	A 022
			Aluminium rigid	C	013			Discharge plenum with round fitting DN200	insulated
	Vertical wall	B	Plastic adjustable	C	022			Discharge bend	insulated
	Vertical wall/ horizontal ceiling	C	Plastic adjustable	C	032		Flexible canvas discharge connector		A 112
			Aluminium rigid	C	033			Discharge sound attenuator connector	
	Vertical wall	D	Plastic adjustable	C	042			Geko-Drive – motorized regulated discharge profile ***	left right
	Vertical wall/ horizontal ceiling; with unit foot cover **	A	Plastic adjustable	C	052			Air intake plenum with primary air connection DN 125	not insulated
			Aluminium rigid	C	053			Air intake plenum with round connection DN 200	not insulated
	Vertical wall; with unit foot cover **	B	Plastic adjustable	C	062			Air intake bend	not insulated
	Vertical wall/hori- zontal ceiling; with unit foot cover and intake front grille **	A	Plastic adjustable	C	072		Intake flexible connection (transition piece required)		A 111
			Aluminium rigid	C	073			Transition piece for intake flexible connection, telescopic and sound-attenuator connection	
	Vertical wall, with unit foot cover and intake front grille **	B	Plastic adjustable	C	082			Intake telescopic connection (transition piece required)	not insulated
	Horizontal ceiling; closed rear side	C	Plastic adjustable	C	132			Intake sound attenuator connection for recirculating-air unit (transition piece required)	
			Aluminium rigid	C	133			Seal cap for round fitting, DN 200 *	insulated
	Vertical stand-alone installation closed on rear side	C	Plastic adjustable	C	232			Unit feet for recirculating-air units *	
			Aluminium rigid	C	233			Spare filter (5 pieces)	G1
	G2	A 823							
	G3	A 833							

\*\* Unit feet ZGF.0A913 required

Order code: Z G F . [ ] [ ] [ ] [ ] [ ]

\*\*\* Note! Geko-Drive only together with unit casing!

Valves					Connection/shut-off		Medium connection	
MATRIX 2000	MATRIX 3000/4000	Terminal box	Drive	Operating voltage/circuit			Left	L
•	•	•	2-point open/close	230 V AC <sup>2)</sup>	0	Inlet/outlet flow with outside thread	Right	R
•	•	•	2-point open/close	24 V AC <sup>1), 2)</sup>	1	Inlet/outlet with solder fitting		
•	•	•	3-point open/stop/close	230 V AC	2	Inlet/outlet + ball trap with external thread		
•	•	•	3-point open/stop/close	24 V AC <sup>1)</sup>	3	Inlet/outlet + ball trap with solder fitting		
•	•	•	3-point open/stop/close	230 V AC + 2 contacts	4	Inlet + ball trap/ outlet + shut-off valve with external thread		
		•	Continuous	0/2 ... 10 V = 24 V AC <sup>1)</sup>	5	Inlet + ball trap/ outlet + shut-off valve with solder fitting		

Cool / heat circuit		k <sub>VS</sub> values	
	3	Cooling/Heating	
		0.25	≡ 03
		0.40	≡ 04
		0.63	≡ 06
		1.00	≡ 10
		1.60 <sup>2)</sup>	≡ 16
		2.50 <sup>2)</sup>	≡ 25
		4.00	≡ 40

Order code: V G F . [ ] 3 [ ] [ ] . [ ] [ ]

Cooling/heating circuit

1) 24 V-transformer to be provided by others  
 2) k<sub>VS</sub>-values for open/close actuators (T,Q) only k<sub>VS</sub> 1.6 and 2.5 possible

**FläktGroup MATRIX 2000**

**System features MATRIX 2000:**

- Extended temperature assignment.: 7...40 °C (default 10..30 °C)
- Manual assignment of speed stage
- Adjustable regulating range
- Change-over between normal/economy mode on control panel
- Room temperature measurement using control panel
- External room temperature sensor can be connected
- Valve control (2-point)
- Temperature control with fan speed change-over and valve(s)
- Status messages using LED
- Group control
- Group switch-off switch-off in case of fault
- Motor temperature monitoring (TC required)
- Network-enabled

**MATRIX OP21C**

- Control panel for MATRIX 2000
- Pure white casing, protection type IP20
  - Setpoint temperature setting
  - Speed stage selection switch 0-A (Auto)-1-2-3
  - Economy mode button
  - LEDs for operation/fault/ext.control
  - Integrated room temperature sensor

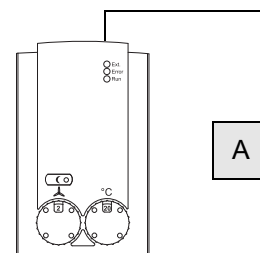

**FläktGroup MATRIX 3000/4000**

**System features MATRIX 3000:**

- Temperature assignment.: 7...40 °C (default 10..30 °C)
- Speed (stage) assignment
- Adjustable regulating range
- Change-over between normal/economy mode on control panel
- Input for change-over between normal/economy mode or unit OFF with frost protection
- Room temperature measurement using control panel
- External room temperature sensor can be connected
- Valve control (2x2 or 2x3 point)
- Temperature control via fan and/or valve(s)
- Room frost protection
- Status messages using LED
- Status and fault signals using floating change-over contacts
- Unit individual and group control
- Isolation of individual units in case of fault
- Motor temperature monitoring (with speed stage motors TC required)
- Network-enabled

**MATRIX OP30C**

- Control panel for MATRIX 3000/4000
- Pure white casing, protection type IP20
  - Setpoint temperature setting
  - Speed-stage selection switch 0-A(Auto)-1-2-3-4-5 (depends on motor type, with EC motor up to 5 stages)
  - LEDs for operation/fault/ext.control
  - Integrated room temperature sensor

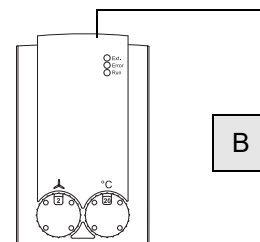

**MATRIX OP31C**

- As for control panel OP30C, but also with:
- Normal/economy mode buttons

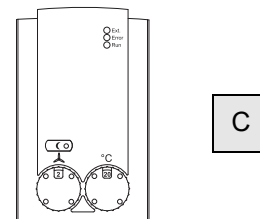

**MATRIX OP44C**

- As for control panel OP31C, but also with button for:
- Changeover between recirculating-air/ mixed-air operation
  - Change-over heating/cooling/automatic mode

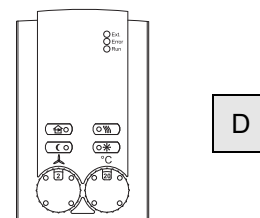

**Additional features MATRIX 4000:**

- Summer / winter compensation
- Noiseless valve control
- Cool and/or heat request via volt-free contacts (related to water circuit)
- Stand alone unit control
- Inputs for operating mode:
  - Normal mode
  - Economy mode
  - Autonomous mode
  - Unit OFF

**MATRIX OP50C**

- Control panel for MATRIX 3000/4000
- Pure white casing, protection type IP20
  - Menu-guided controls using rotation navigator
  - LCD display with plain-text display
  - Status messages using pictograms
  - Integrated room temperature sensor
  - Continuous speed regulation (only with EC motor)

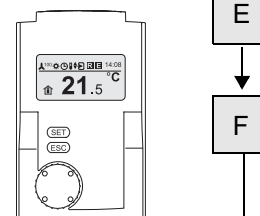

**MATRIX OP51C**

- As for control panel OP50C, but also with:
- Integrated weekly clock timer with a holiday and special days programme

**MATRIX.IR**

- Infrared remote control for control system MATRIX 3000/4000
- Black casing, RAL 9004
  - LCD display approx. 45x30 mm
  - Function as in OP44C (without status, fault and external control signals, no integrated room temperature sensor)
  - Maximum range 20 m
  - Speed-stage selection switch 0-A(Auto)-1-2-3-4-5 (depends on motor type, with EC motor up to 5 stages)



E

F

N

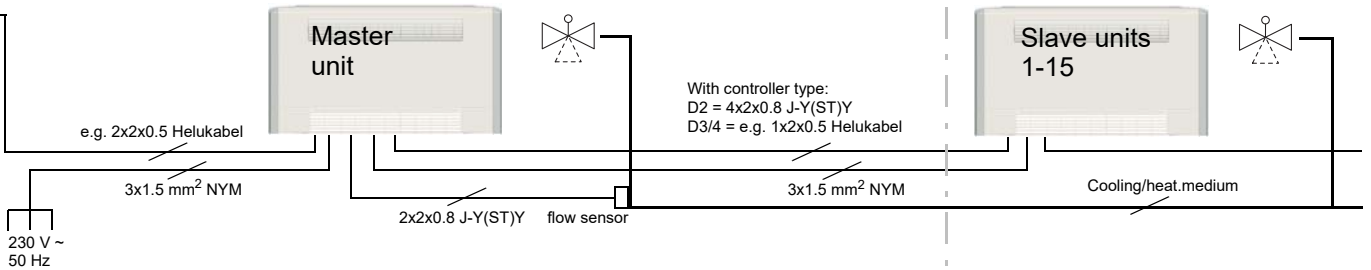
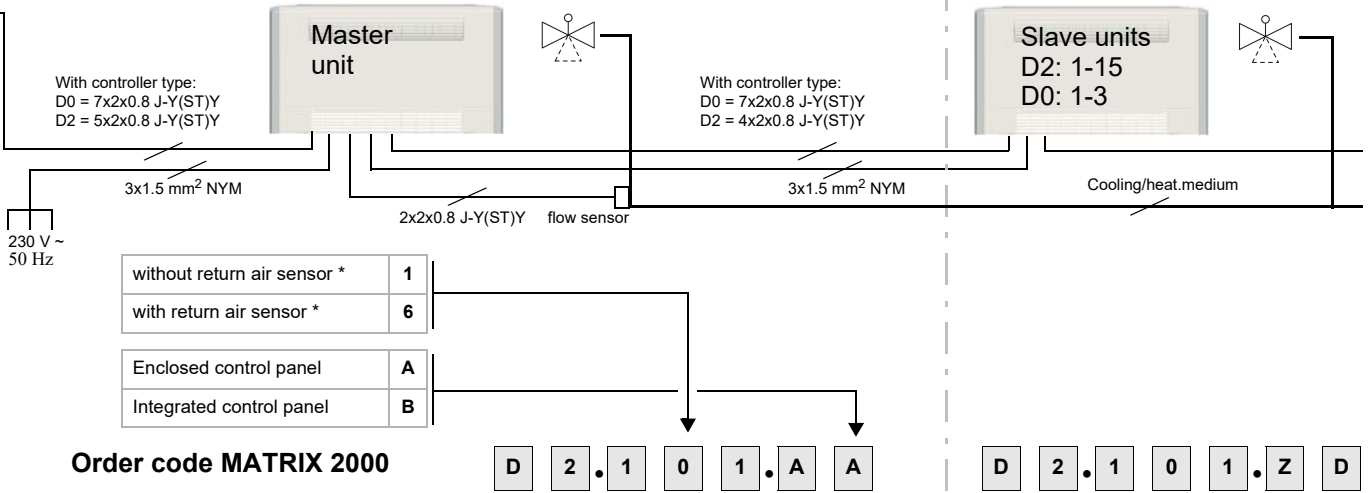

	Speed (EC motor)	Speed stages (AC motor)	Features							Order code			
			Stand alone unit control with operating- and Fault signal	Group regulation with status and alarm signals	Input unit OFF with room frost protection	Input economy contact	Supply temperature limitation	Noiseless valve control	Contact heat and cool request	Geko-Drive	Connection external sensor		
Continuous	up to 3 speed		•	•							3	1	
			•		•						3	2	
		•		•							3	1	
		•			•						3	2	
		•				•					3	3	
		•					•				3	4	
		•						•			4	1	
	up to 5 speed	•			•						•	4	2
		•				•					•	4	3
		•					•				•	4	4
		•				•					•	4	5
		•					•				•	4	6
		•						•			•	4	6
		•							•		•	4	6

2	0	1
2	0	1
3		1
3		2
3		3
3		4
4		1
4		2
4		3
4		4
4		5
4		6
4		6

Without return air sensor *	0
With return air sensor *	5
Control panel	
Enclosed control panel	A
Integrated control panel	B

**Order code**

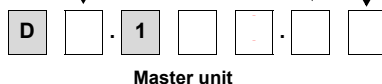

\* Alternatively room temperature sensor (see Page 99)

# Recirculating-Air Unit Heating or Cooling

2-pipe chilled or warm water  
with auxiliary electrical heating (AEH),  
Model sizes 1 to 8

Flex-Geko

CWP 6/12 °C PWW 70/50 °C Electric heater  
t<sub>L1</sub> = +27 °C t<sub>L1</sub> = +20 °C 230V~N/P/E  
φ<sub>1</sub> = 46 % r.h. 50Hz

Model size	Speeds	+ Air volume m <sup>3</sup> /h	Capacity stage 1				Capacity stage 2				Capacity stage 3				E heating		AC motor		EC motor	
			•Cooling capacity Q <sub>K</sub> kW	Pressure drop Δp <sub>K</sub> kPa	•Heating capacity Q <sub>H</sub> kW	•Pressure drop Q <sub>H</sub> kW	•Cooling capacity Q <sub>K</sub> kW	Pressure drop Δp <sub>K</sub> kPa	•Heating capacity Q <sub>H</sub> kW	•Pressure drop Q <sub>H</sub> kW	•Cooling capacity Q <sub>K</sub> kW	Pressure drop Δp <sub>K</sub> kPa	•Heating capacity Q <sub>H</sub> kW	•Pressure drop Q <sub>H</sub> kW	•AEX Speed L Q <sub>H</sub> kW	•AEX Speed M Q <sub>H</sub> kW	Sound power dB(A)	Sound pressure* dB(A)	Sound power dB(A)	Sound pressure* dB(A)
1	2	220	1.2	9.2	2.3	2.6	1.4	3.4	2.6	1.0	1.6	4.1	2.9	1.1	0.87	-	36	28	37	28
1	3	270	1.4	11.4	2.6	3.4	1.7	4.6	3.1	1.4	1.9	5.5	3.4	1.6	0.87	0.87	42	33	42	33
1	4	350	1.6	14.9	3.1	4.6	1.9	6.2	3.7	1.9	2.3	8.1	4.2	2.3	1.74	0.87	48	39	48	39
1	5	530	2.0	21.9	3.9	7.2	2.5	9.9	5.0	3.3	3.0	13.0	5.5	3.9	-	1.74	58	50	58	50
2	1	230	1.5	17.7	2.6	4.5	1.7	6.2	3.0	1.6	1.7	1.7	3.1	0.5	1.27	-	35	26	36	27
2	3	280	1.7	22.1	3.1	5.9	2.0	8.3	3.6	2.2	2.0	2.5	3.7	0.7	1.27	1.27	42	33	41	32
2	4	360	2.0	29.1	3.6	8.1	2.4	11.1	4.3	3.2	2.5	3.7	4.6	1.1	2.54	1.27	46	37	47	38
2	5	540	-	-	4.7	13.0	3.1	18.4	5.8	5.4	3.4	6.4	6.2	1.8	-	2.54	58	49	58	49
3	1	350	2.0	7.2	3.7	2.1	2.5	4.9	4.5	1.4	2.7	4.9	4.6	1.3	1.67	-	35	27	36	27
3	3	470	2.4	10.0	4.6	3.0	3.1	7.4	5.6	2.1	3.4	7.6	6.0	2.0	1.67	1.67	43	34	43	34
3	4	670	3.0	14.7	5.8	4.7	3.9	11.2	7.2	3.3	4.4	12.2	7.9	3.4	3.34	1.67	52	44	52	43
3	5	890	3.4	19.1	6.8	6.4	4.5	15.1	8.8	4.8	5.3	17.5	9.6	4.9	-	3.34	59	51	59	50
4	1	360	2.3	10.4	4.1	2.9	2.8	6.9	4.8	1.8	2.9	3.7	5.0	0.9	1.95	-	35	26	34	25
4	3	490	2.8	15.0	5.1	4.3	3.5	10.5	6.2	2.8	3.7	5.9	6.5	1.5	1.95	1.95	41	32	41	33
4	4	720	3.5	22.6	6.6	6.8	4.5	17.2	8.2	4.8	5.0	10.0	8.9	2.7	3.90	1.95	51	42	51	42
4	5	990	4.1	30.8	8.1	9.9	5.5	24.4	10.1	7.1	6.2	15.1	11.1	4.1	-	3.90	58	50	59	50
5	1	370	2.5	13.9	4.4	3.7	3.0	9.3	5.1	2.3	3.1	4.9	5.2	1.2	2.03	-	34	25	33	24
5	3	520	3.2	21.3	5.7	5.8	3.9	14.7	6.7	3.8	4.2	8.2	7.1	2.0	2.03	2.03	42	34	41	33
5	4	740	3.9	31.5	7.2	9.0	5.0	23.0	8.9	6.3	5.4	13.3	9.4	3.4	4.06	2.03	51	42	51	42
5	5	1010	4.7	43.0	8.8	13.0	6.1	33.4	11.0	9.2	6.7	19.5	12.0	5.3	-	4.06	59	51	59	51
6	1	560	3.1	3.9	5.9	1.2	3.8	2.6	7.1	0.8	3.7	1.2	7.2	0.4	2.07	-	39	31	40	31
6	3	750	3.8	5.4	7.3	1.7	4.8	4.0	8.8	1.2	5.0	2.1	9.4	0.6	2.07	2.07	46	38	47	38
6	4	990	4.4	7.3	8.8	2.4	5.7	5.6	10.8	1.7	6.3	3.2	11.6	0.9	4.14	2.07	55	47	54	46
6	5	1310	5.2	9.8	10.5	3.4	6.8	7.6	13.1	2.4	7.6	4.5	14.2	1.4	-	4.14	62	54	62	53
7	1	580	3.5	5.0	6.4	1.5	4.2	3.4	7.5	0.9	4.3	1.7	7.8	0.5	2.07	-	38	30	39	30
7	3	770	4.2	7.1	7.8	2.1	5.2	5.0	9.5	1.4	5.5	2.7	10.0	0.8	2.07	2.07	46	38	46	37
7	4	1030	5.0	9.8	9.5	3.0	6.4	7.3	11.7	2.1	6.8	4.1	12.6	1.2	4.14	2.07	54	45	54	45
7	5	1420	5.9	13.4	11.7	4.5	7.8	10.6	14.6	3.2	8.7	6.3	15.9	1.8	-	4.14	62	53	62	54
8	1	690	4.2	7.7	7.6	2.2	5.0	5.1	8.9	1.4	5.2	2.7	9.2	0.7	2.07	-	38	29	38	29
8	3	970	5.2	11.3	9.6	3.3	6.4	7.9	11.7	2.2	6.8	4.4	12.1	1.2	2.07	2.07	46	37	46	37
8	4	1380	6.3	16.3	12.1	5.1	8.2	12.6	15.0	3.6	8.9	7.1	16.1	2.0	4.14	2.07	55	46	54	46
8	5	1820	7.3	21.1	14.4	7.0	9.6	16.9	18.1	5.0	10.8	10.1	19.6	2.9	-	4.14	61	53	61	53

Motor design		
AC motor	TC integr.	0
	TC led out	1
EC motor		E

Metal-sheet electric control box with terminal block or for integrated controls



Speed stages combinations

2-3-4	L
3-4-5	M
Min..Max (EC motor)	S

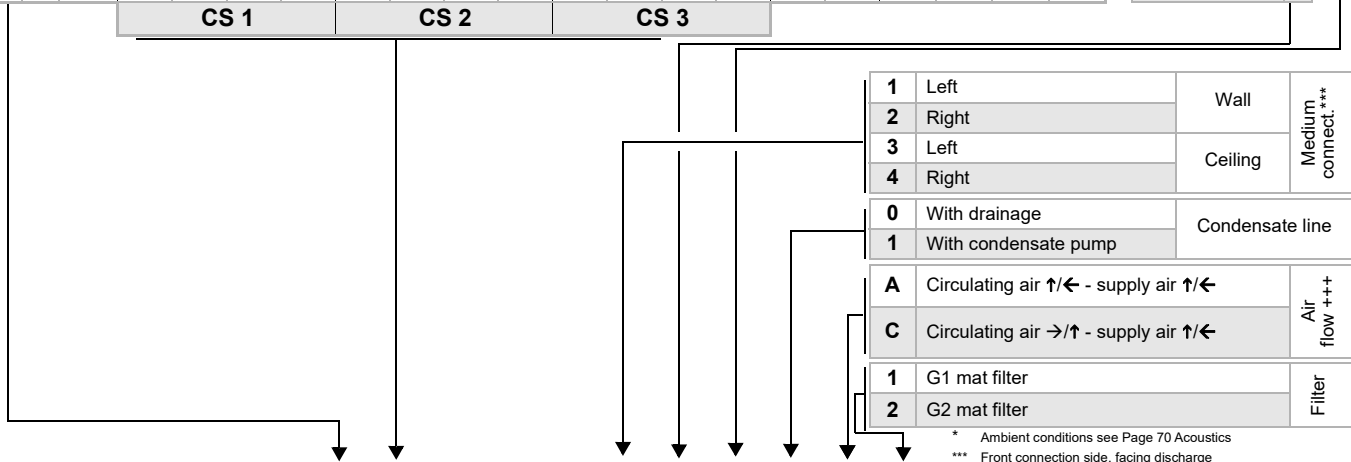

\* Ambient conditions see Page 70 Acoustics  
 ... Front connection side, facing discharge  
 ... Air volume flow for CS 1 and filter class G1  
 ... Definition of air flow wall/ceiling see Page 74

Order code

**G** **F** **U** **W** **B**

2-pipe system chilled or warm water and auxiliary electric heating, sizes 1 to 8

### Accessories

Arrangement/ installation	Variant/ unit casing	Suitable for air flow designation	Discharge grille	Code	Variant	Type	Code
	Vertical wall/horizontal ceiling	A	Aluminium rigid	C 013		Air intake plenum with primary air connection DN 125	not insulated A 011
	Vertical wall/horizontal ceiling	C	Aluminium rigid	C 033		Air intake bend	not insulated A 051
	Vertical wall/horizontal ceiling; with unit foot cover **	A	Aluminium rigid	C 053		Transition piece for intake telescopic connection	A 131
	Vertical wall/horizontal ceiling; with unit foot cover and intake front grille **	A	Aluminium rigid	C 073		Intake telescopic connection (transition piece required)	not insulated A 151
	Horizontal ceiling; closed on rear side	C	Aluminium rigid	C 133		Unit feet for recirculating-air units *	A 913
	Vertical stand-alone installation closed on rear side	C	Aluminium rigid	C 233		Spare filter (5 pieces)	G1 A 813 G2 A 823

\*\* Unit feet ZGF.0A913 required

**Sizes 1 to 8**  
\* 0, if irrespective of size

**Order code** Z G F . [ ] [ ] [ ] [ ]

### Valves

MATRIX 2000	MATRIX 3000/4000	Terminal box	Drive	Operating voltage/circuit	
			• 2-point open/close	230 V AC <sup>2)</sup>	T
			• 2-point open/close	24 V AC <sup>1), 2)</sup>	Q
			• 3-point open/stop/close	230 V AC	R
			• 3-point open/stop/close	24 V AC <sup>1)</sup>	N
			• 3-point open/stop/close	230 V AC + 2 contacts	C
			• Continuous	0/2 ... 10 V = 24 V AC <sup>1)</sup>	S

Connection/shut-off		Medium connection	
Inlet/outlet flow with outside thread	0	Left	L
Inlet/outlet with solder fitting	1	Right	R
Inlet/outlet + ball trap with external thread	2		
Inlet/outlet + ball trap with solder fitting	3		
Inlet + ball trap/outlet + shut-off valve with external thread	4		
Inlet + ball trap/outlet + shut-off valve with solder fitting	5		

k <sub>vs</sub> values		
Cooling/Heating		
0.25	≡	03
0.40	≡	04
0.63	≡	06
1.00	≡	10
1.60 <sup>2)</sup>	≡	16
2.50 <sup>2)</sup>	≡	25
4.00	≡	40

**Cool / heat circuit**

3

**Order code** V G F . [ ] 3 [ ] [ ] [ ] [ ]

Cooling/heating circuit

1) 24 V-transformer to be provided by others  
2) k<sub>vs</sub>-values for open/close actuators (T,Q) only k<sub>vs</sub> 1.6 and 2.5 possible

2-pipe chilled or warm water and auxiliary electric heating, sizes 1 to 8

**FläktGroup MATRIX 2000**

not applicable

**FläktGroup MATRIX 4000**

**System features MATRIX 4000:**

- Temperature assignment.: 7...40 °C (default 10..30 °C)
- Assignment of speed stage
- Adjustable regulating range
- Change-over between normal/economy mode on control panel
- Input for change-over between normal/economy mode or unit OFF with frost protection
- Room temperature measurement using control panel
- External room temperature sensor can be connected
- Valve control (2 or 3 point)
- Temperature control via fan and/or valve
- Room frost protection
- Status messages using LED
- Status and alarm signal via volt free change-over contacts
- Unit individual and group control
- Isolation of individual units in case of fault
- Motor temperature monitoring (with speed stage motors TC required)
- Network-enabled
- Summer / winter compensation
- Noiseless valve control
- Cool and/or heat request via volt-free contacts (related to water circuit)
- Stand alone unit control
- Inputs for operating mode:
  - Normal mode
  - Economy mode
  - Autonomous mode
  - Unit OFF
- Regulation of multi-stage electrical heating with disconnection in case of over-temperature

**MATRIX OP30C**

- Control panel for MATRIX 4000
- Pure white casing, protection type IP20
  - Setpoint temperature setting
  - Speed-stage selection switch 0-A(Auto)-1-2-3-4-5 (depends on motor type, with EC motor up to 5 stages)
  - LEDs for operation/fault/ext.control
  - Integrated room temperature sensor

**MATRIX OP31C**

- As for control panel OP30C, but also with:
- Normal/economy mode buttons

**MATRIX OP44C**

- As for control panel OP31C, but also with button for:
- Changeover between recirculating-air/mixed-air operation
  - Change-over heating/cooling/automatic mode

**MATRIX OP50C**

- Control panel for MATRIX 4000
- Pure white casing, protection type IP20
  - Menu-guided controls using rotation navigator
  - LCD display with plain-text display
  - Status messages using pictograms
  - Integrated room temperature sensor

**MATRIX OP51C**

- As for control panel OP50C, but also with:
- Integrated weekly clock timer with holiday and special days programme

**MATRIX.IR**

- Infrared remote control for MATRIX 4000
- Black casing, RAL 9004
  - LCD display approx. 45x30 mm
  - Function as in OP44C (without status, alarm and external control signals, no integrated room temperature sensor)
  - Maximum range 20 m
  - Speed-stage selection switch 0-A(Auto)-1-2-3-4-5 (depends on motor type, with EC motor up to 5 stages)

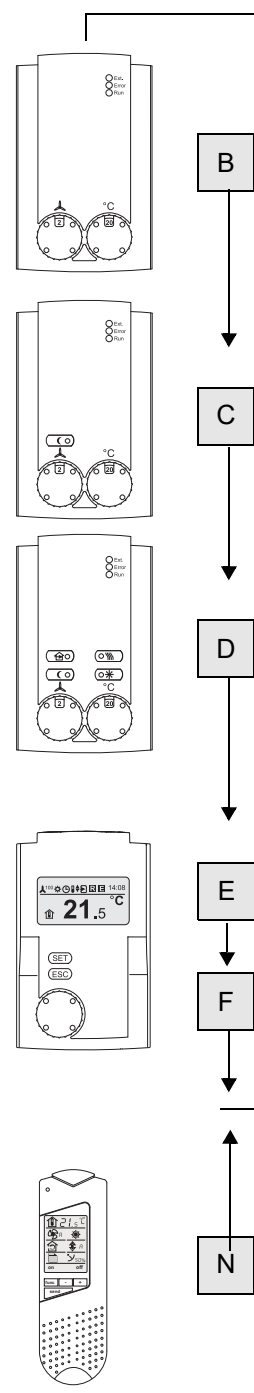

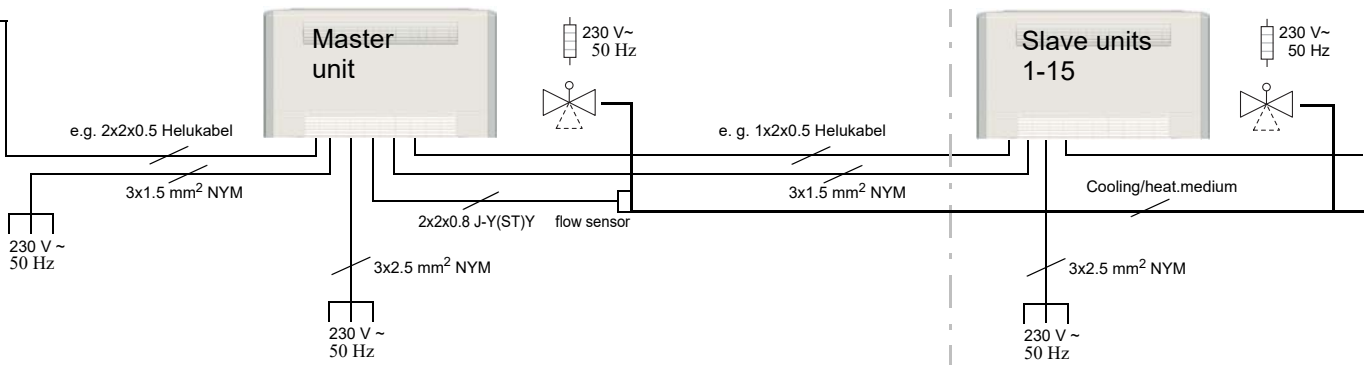

Speed EC motor	Speeds	Stand alone unit control with operating- and Fault signal	Input unit OFF with room frost protection	Input economy contact	Noiseless valve control	Contact heat and cool request	Connection external sensor		
Continuous	up to 3 speed	•	•	•	•	•	•	1	1
		•	•	•	•	•	•	2	2
		•	•	•	•	•	•	5	5

Without return air sensor *	1
With return air sensor *	6
Control panel	
Enclosed control panel	A
Integrated control panel	B

**Order code**

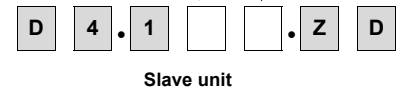
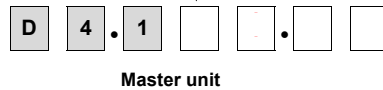

\* Alternatively room temperature sensor (see Page 99)

Sizes 1 to 8

Model size	Speeds	Air volume m <sup>3</sup> /h	Capacity stage 1				Capacity stage 2				Capacity stage 3				AC motor		EC motor	
			•Cooling capacity Q <sub>K</sub> kW	Pressure drop Δp <sub>K</sub> kPa	•Heating capacity Q <sub>H</sub> kW	Pressure drop Δp <sub>H</sub> kPa	•Cooling capacity Q <sub>K</sub> kW	Pressure drop Δp <sub>K</sub> kPa	•Heating capacity Q <sub>H</sub> kW	Pressure drop Δp <sub>H</sub> kPa	•Cooling capacity Q <sub>K</sub> kW	Pressure drop Δp <sub>K</sub> kPa	•Heating capacity Q <sub>H</sub> kW	Pressure drop Δp <sub>H</sub> kPa	Sound power dB(A)	Sound pressure* dB(A)	Sound power dB(A)	Sound pressure* dB(A)
1	1	150	-	-	1.7	1.6	-	-	1.9	0.6	-	-	2.0	0.6	30	21	28	< 20
	2	220	-	-	2.3	2.6	-	-	2.6	1.0	-	-	2.9	1.1	36	28	37	28
	3	270	-	-	2.6	3.4	-	-	3.1	1.4	-	-	3.4	1.6	42	33	42	33
	4	350	-	-	3.1	4.6	-	-	3.7	1.9	-	-	4.2	2.3	48	39	48	39
	5	530	-	-	3.9	7.2	-	-	5.0	3.3	-	-	5.5	3.9	58	50	58	50
2	1	160	-	-	2.0	2.8	-	-	2.2	0.9	-	-	2.2	0.3	28	< 20	28	< 20
	2	230	-	-	2.6	4.5	-	-	3.0	1.6	-	-	3.1	0.5	35	26	36	27
	3	280	-	-	3.1	5.9	-	-	3.6	2.2	-	-	3.7	0.7	42	33	41	32
	4	360	-	-	3.6	8.1	-	-	4.3	3.2	-	-	4.6	1.1	46	37	47	38
	5	540	-	-	4.7	13.0	-	-	5.8	5.4	-	-	6.2	1.8	58	49	58	49
3	1	280	-	-	3.2	1.6	-	-	3.7	1.0	-	-	3.8	0.9	30	21	30	22
	2	350	-	-	3.7	2.1	-	-	4.5	1.4	-	-	4.6	1.3	35	27	36	27
	3	470	-	-	4.6	3.0	-	-	5.6	2.1	-	-	6.0	2.0	43	34	43	34
	4	670	-	-	5.8	4.7	-	-	7.2	3.3	-	-	7.9	3.4	52	44	52	43
	5	890	-	-	6.8	6.4	-	-	8.8	4.8	-	-	9.6	4.9	59	51	59	50
4	1	290	-	-	3.5	2.1	-	-	4.0	1.3	-	-	4.1	0.7	29	20	29	20
	2	360	-	-	4.1	2.9	-	-	4.8	1.8	-	-	5.0	0.9	35	26	34	25
	3	490	-	-	5.1	4.3	-	-	6.2	2.8	-	-	6.5	1.5	41	32	41	33
	4	720	-	-	6.6	6.8	-	-	8.2	4.8	-	-	8.9	2.7	51	42	51	42
	5	990	-	-	8.1	9.9	-	-	10.1	7.1	-	-	11.1	4.1	58	50	59	50
5	1	300	-	-	3.7	2.7	-	-	4.3	1.7	-	-	4.3	0.8	28	20	28	< 20
	2	370	-	-	4.4	3.7	-	-	5.1	2.3	-	-	5.2	1.2	34	25	33	24
	3	520	-	-	5.7	5.8	-	-	6.7	3.8	-	-	7.1	2.0	42	34	41	33
	4	740	-	-	7.2	9.0	-	-	8.9	6.3	-	-	9.4	3.4	51	42	51	42
	5	1010	-	-	8.8	13.0	-	-	11.0	9.2	-	-	12.0	5.3	59	51	59	51
6	1	430	-	-	4.9	0.8	-	-	5.7	0.5	-	-	5.7	0.3	33	24	33	24
	2	560	-	-	5.9	1.2	-	-	7.1	0.8	-	-	7.2	0.4	39	31	40	31
	3	750	-	-	7.3	1.7	-	-	8.8	1.2	-	-	9.4	0.6	46	38	47	38
	4	990	-	-	8.8	2.4	-	-	10.8	1.7	-	-	11.6	0.9	55	47	54	46
	5	1310	-	-	10.5	3.4	-	-	13.1	2.4	-	-	14.2	1.4	62	54	62	53
7	1	460	-	-	5.4	1.1	-	-	6.2	0.7	-	-	6.4	0.3	33	24	33	24
	2	580	-	-	6.4	1.5	-	-	7.5	0.9	-	-	7.8	0.5	38	30	39	30
	3	770	-	-	7.8	2.1	-	-	9.5	1.4	-	-	10.0	0.8	46	38	46	37
	4	1030	-	-	9.5	3.0	-	-	11.7	2.1	-	-	12.6	1.2	54	45	54	45
	5	1420	-	-	11.7	4.5	-	-	14.6	3.2	-	-	15.9	1.8	62	53	62	54
8	1	590	-	-	6.8	1.7	-	-	7.8	1.1	-	-	7.7	0.5	34	25	34	26
	2	690	-	-	7.6	2.2	-	-	8.9	1.4	-	-	9.2	0.7	38	29	38	29
	3	970	-	-	9.6	3.3	-	-	11.7	2.2	-	-	12.1	1.2	46	37	46	37
	4	1380	-	-	12.1	5.1	-	-	15.0	3.6	-	-	16.1	2.0	55	46	54	46
	5	1820	-	-	14.4	7.0	-	-	18.1	5.0	-	-	19.6	2.9	61	53	61	53

Motor design		
AC motor	TC integr.	0
	TC led out	1
EC motor		E

Plastic terminal box (with MATRIX metal sheet electrical control box)



Speed combination

1-2-3 <sup>+</sup>	A
2-3-4 <sup>+</sup>	B
3-4-5 <sup>+</sup>	C
1-3-5 <sup>+</sup>	E
1-2-3-4-5 <sup>+</sup>	H
Min..Max (EC motor)	F

Metal sheet electric control box with terminal strip or for integ. Controls



Speed combination

1-2-3 <sup>+</sup>	K
2-3-4 <sup>+</sup>	L
3-4-5 <sup>+</sup>	M
1-3-5 <sup>+</sup>	O
1-2-3-4-5 <sup>+</sup>	R
Min..Max (EC motor)	S

Data for capacity stage 4 (CS 4) are available on request (see Page 11).

1	Left	Wall	Medium connect.***
2	Right		
3	Left	Ceiling	
4	Right		
A	Circulating air ↑/← - supply air ↑/←		Air flow +++
B	Circulating air ↑/← - supply air ←/↓		
C	Circulating air →/↑ - supply air ↑/←		
D	Circulating air →/↑ - supply air ←/↓		
1	G1 mat filter		Filter
2	G2 mat filter		
3	G3 mat filter		

\* Ambient conditions see Page 70 Acoustics  
 \*\*\* Front connection side, facing discharge  
 + only AC motor  
 ++ Air volume flow for CS 1 and filter class G1  
 \*\*\* Definition of air flow wall/ceiling see Page 74

Order code

G F . U 0 W . 0



### Accessories

Arrangement/ installation	Variant/ unit casing	Suitable for air flow designation	Discharge grille	Code	Variant	Type	Code
	Vertical wall/ horizontal ceiling	A	Plastic adjustable	C 012		not insulated	A 012
			Aluminium rigid	C 013		insulated	A 022
	Vertical wall/ horizontal ceiling	B	Plastic adjustable	C 022		not insulated	A 032
			Aluminium rigid	C 033		insulated	A 042
	Vertical wall/ horizontal ceiling	C	Plastic adjustable	C 032		not insulated	A 052
			Aluminium rigid	C 033		insulated	A 062
	Vertical wall/ horizontal ceiling	D	Plastic adjustable	C 042		A 112	
			Plastic adjustable	C 052			not insulated
	Vertical wall/ horizontal ceiling; with unit foot cover **	A	Plastic adjustable	C 052			A 212
			Aluminium rigid	C 053			not insulated
	Vertical wall/ horizontal ceiling; with unit foot cover **	B	Plastic adjustable	C 062			not insulated
			Aluminium rigid	C 072			not insulated
	Vertical wall/ horizontal ceiling; with unit foot cover and intake front grille **	A	Plastic adjustable	C 072			A 111
			Aluminium rigid	C 073			A 131
	Vertical wall/ horizontal ceiling; on front side with unit foot cover and intake front grille **	B	Plastic adjustable	C 082			not insulated
			Aluminium rigid	C 132			A 211
	Horizontal ceiling; closed rear side	C	Plastic adjustable	C 132			insulated
			Aluminium rigid	C 133			A 913
	Vertical stand-alone installation; closed on rear side	C	Plastic adjustable	C 232			G1
			Aluminium rigid	C 233		G2	A 823
						G3	A 833

\*\* Unit feet ZGF.0A913 required

**Sizes 1 to 8**  
\* 0, if irrespective of size

**Order code**    Z   G   F . [ ] [ ] [ ] [ ]

### Valves

MATRIX 500	MATRIX 2000	MATRIX 3000/4000	Terminal box	Drive	Operating voltage/circuit	
•	•	•	•	2-point open/close	230 V AC <sup>2)</sup>	T
	•	•	•	2-point open/close	24 V AC <sup>1), 2)</sup>	Q
		•	•	3-point open/stop/close	230 V AC	R
		•	•	3-point open/stop/close	24 V AC <sup>1)</sup>	N
			•	3-point open/stop/close	230 V AC + 2 contacts	C
			•	Continuous	0/2 ... 10 V = 24 V AC <sup>1)</sup>	S

Connection/shut-off		Medium connection
Inlet/outlet flow with outside thread	0	Left    L
Inlet/outlet with solder fitting	1	Right   R
Inlet/outlet + ball trap with external thread	2	
Inlet/outlet + ball trap with solder fitting	3	
Inlet + ball trap/ outlet + shut-off valve with external thread	4	
Inlet + ball trap/ outlet + shut-off valve with solder fitting	5	

k <sub>vs</sub> values Heating		
0.25	≡	03
0.40	≡	04
0.63	≡	06
1.00	≡	10
1.60 <sup>2)</sup>	≡	16
2.50 <sup>2)</sup>	≡	25
4.00	≡	40

**Heating circuit**

**Order code**    V   G   F . [ ] [ ] [ ] [ ] . [ ] [ ]

Heating circuit

1) 24 V-transformer to be provided by others  
2) k<sub>vs</sub>-values for open/close actuators (T,Q) only k<sub>vs</sub> 1.6 and 2.5 possible

### FläktGroup MATRIX 2000

#### System features MATRIX 2000:

- Extended temperature assignment.: 7...40 °C (default 10...30 °C)
- Manual assignment of speed stage
- Adjustable regulating range
- Change-over between normal/economy mode on control panel
- Room temperature measurement using control panel
- External room temperature sensor can be connected
- Valve control (2-point)
- Temperature control via fan speed change and valve(s)
- Status messages using LED
- Group control
- Group switch-off switch-off in case of fault
- Motor temperature monitoring (TC required)
- Network-enabled

### MATRIX OP21C

Control panel for MATRIX 2000

- Pure white casing, protection type IP20
- Setpoint temperature setting
- Speed stage selection switch 0-A (Auto)-1-2-3
- Economy mode button
- LEDs for operation/fault/ext.control
- Integrated room temperature sensor

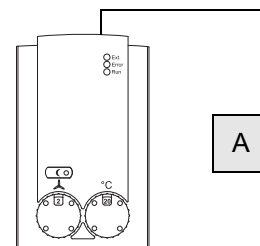

A

### FläktGroup MATRIX 3000/4000

#### System features MATRIX 3000:

- Temperature assignment.: 7...40 °C (default 10...30 °C)
- Speed (stage) assignment
- Adjustable regulating range
- Change-over between normal/economy mode on control panel
- Input for change-over between normal/economy mode or unit OFF with frost protection
- Room temperature measurement using control panel
- External room temperature sensor can be connected
- Valve control (2x2 or 2x3 point)
- Temperature control via fan and/or valve(s)
- Room frost protection
- Status messages using LED
- Status and fault signals using floating change-over contacts
- Unit individual and group control
- Isolation of individual units in case of fault
- Motor temperature monitoring (with speed stage motors TC required)
- Network-enabled

#### Additional features MATRIX 4000:

- Summer / winter compensation
- Noiseless valve control
- Cool and/or heat request via volt-free contacts (related to water circuit)
- Stand alone unit control
- Inputs for operating mode:
  - Normal mode
  - Economy mode
  - Autonomous mode
  - Unit OFF

### MATRIX OP30C

Control panel for MATRIX 3000/4000

- Pure white casing, protection type IP20
- Setpoint temperature setting
- Speed-stage selection switch 0-A(Auto)-1-2-3-4-5 (depends on motor type, with EC motor up to 5 stages)
- LEDs for operation/fault/ext.control
- Integrated room temperature sensor

### MATRIX OP31C

As for control panel OP30C, but also with:

- Normal/economy mode buttons

### MATRIX OP44C

As for control panel OP31C, but also with button for:

- Changeover between recirculating-air/ mixed-air operation
- Change-over heating/cooling/automatic mode

### MATRIX OP50C

Control panel for MATRIX 3000/4000

- Pure white casing, protection type IP20
- Menu-guided controls using rotation navigator
- LCD display with plain-text display
- Status messages using pictograms
- Integrated room temperature sensor
- Continuous speed regulation (only together with EC motor)

### MATRIX OP51C

As for control panel OP50C, but also with:

- Integrated weekly clock timer with a holiday and special days programme

### MATRIX.IR

Infrared remote control for MATRIX 3000/4000

- Black casing, RAL 9004
- LCD display approx. 45x30 mm
- Function as in OP44C (without status, fault and external control signals, no integrated room temperature sensor)
- Maximum range 20 m
- Speed-stage selection switch 0-A(Auto)-1-2-3-4-5 (depends on motor type, with EC motor up to 5 stages)

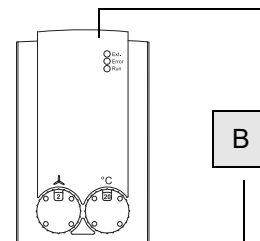

B

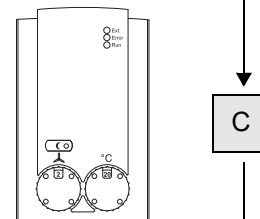

C

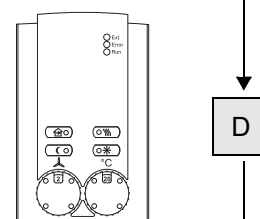

D

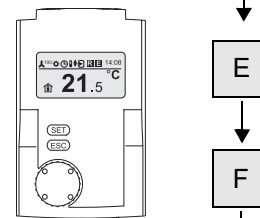

E

F



N

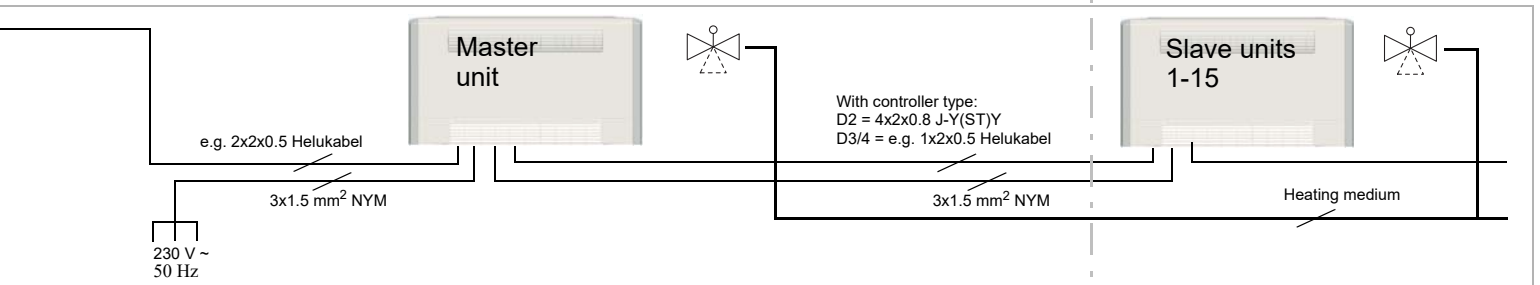
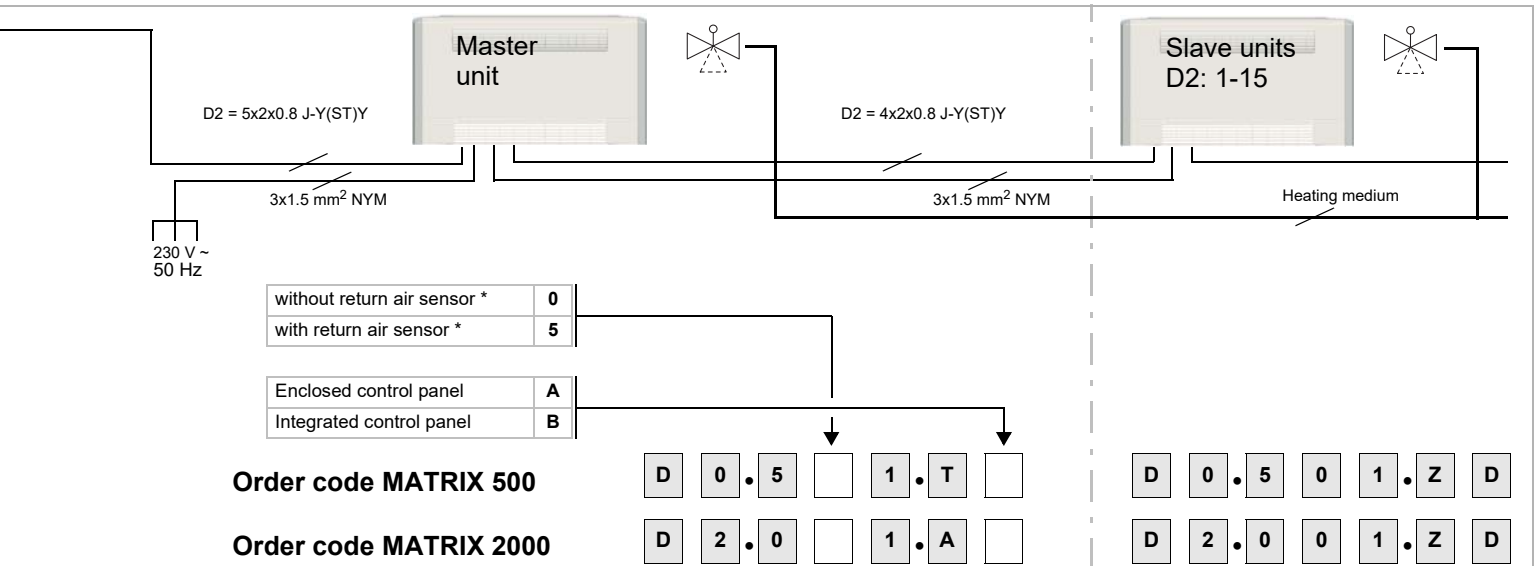

Speed (EC motor)	Speed stages (AC motor)	Stand alone unit control with operating and Fault signal	Group regulation with status and alarm signal	Input unit OFF with room frost protection	Input economy contact	Supply temperature limitation	Noiseless valve control	Contact heat request	Connection external sensor	Matrix		
										3	1	
Continuous	up to 3 speed		•	•						3	1	
			•		•					3	2	
			•			•				3	1	
			•				•			3	2	
			•					•		3	3	
			•						•	3	4	
			•							4	1	
	up to 5 speed									•	4	2
										•	4	3
										•	4	4
										•	4	4
										•	4	5
										•	4	6
										•	4	6

2	0	1
2	0	1
3	1	
3	2	
3	3	
3	4	
4	1	
4	2	
4	3	
4	4	
4	5	
4	6	

Without return air sensor *	0
With return air sensor *	5
Control panel	
Enclosed control panel	A
Integrated control panel	B

**Order code**

D		.	0			.		
---	--	---	---	--	--	---	--	--

Master unit

D		.	0			.	Z	D
---	--	---	---	--	--	---	---	---

Slave unit

\* Alternatively room temperature sensor (see Page 99)

Model size	Speeds	Air volume m <sup>3</sup> /h	Capacity stage 1				AC motor	
			Q <sup>*</sup> Cooling capacity kW	Pressure drop $\Delta p_K$ kPa	Full electric heating Q <sup>*</sup> kW	Pressure drop $\Delta p_H$ kPa	Sound power dB(A)	Sound pressure* dB(A)
1	1	-	-	-	-	-	-	-
	2	-	-	-	-	-	-	-
	3	270	-	-	2.07	-	42	33
	4	350	-	-	2.07	-	48	39
	5	530	-	-	4.14	-	58	50
2	1	-	-	-	-	-	-	-
	2	-	-	-	-	-	-	-
	3	280	-	-	2.52	-	42	33
	4	360	-	-	2.52	-	46	37
	5	540	-	-	5.04	-	58	49
3	1	-	-	-	-	-	-	-
	2	-	-	-	-	-	-	-
	3	470	-	-	3.69	-	43	34
	4	670	-	-	3.69	-	52	44
	5	890	-	-	7.38	-	59	51
4	1	-	-	-	-	-	-	-
	2	-	-	-	-	-	-	-
	3	490	-	-	4.20	-	41	32
	4	720	-	-	4.20	-	51	42
	5	990	-	-	8.40	-	58	50
5	1	-	-	-	-	-	-	-
	2	-	-	-	-	-	-	-
	3	520	-	-	4.89	-	42	34
	4	740	-	-	4.89	-	51	42
	5	1010	-	-	9.78	-	59	51
6	1	-	-	-	-	-	-	-
	2	-	-	-	-	-	-	-
	3	750	-	-	4.98	-	46	38
	4	990	-	-	4.98	-	55	47
	5	1310	-	-	9.96	-	62	54
7	1	-	-	-	-	-	-	-
	2	-	-	-	-	-	-	-
	3	770	-	-	6.18	-	46	38
	4	1030	-	-	6.18	-	54	45
	5	1420	-	-	12.36	-	62	53
8	1	-	-	-	-	-	-	-
	2	-	-	-	-	-	-	-
	3	970	-	-	6.18	-	46	37
	4	1370	-	-	6.18	-	55	46
	5	1820	-	-	12.36	-	61	53

Motor design		
AC motor	TC integr.	0
	TC led out	1

Metal-sheet electric control box with terminal block or for integrated controls



Speed combination

3-4-5	M
-------	---

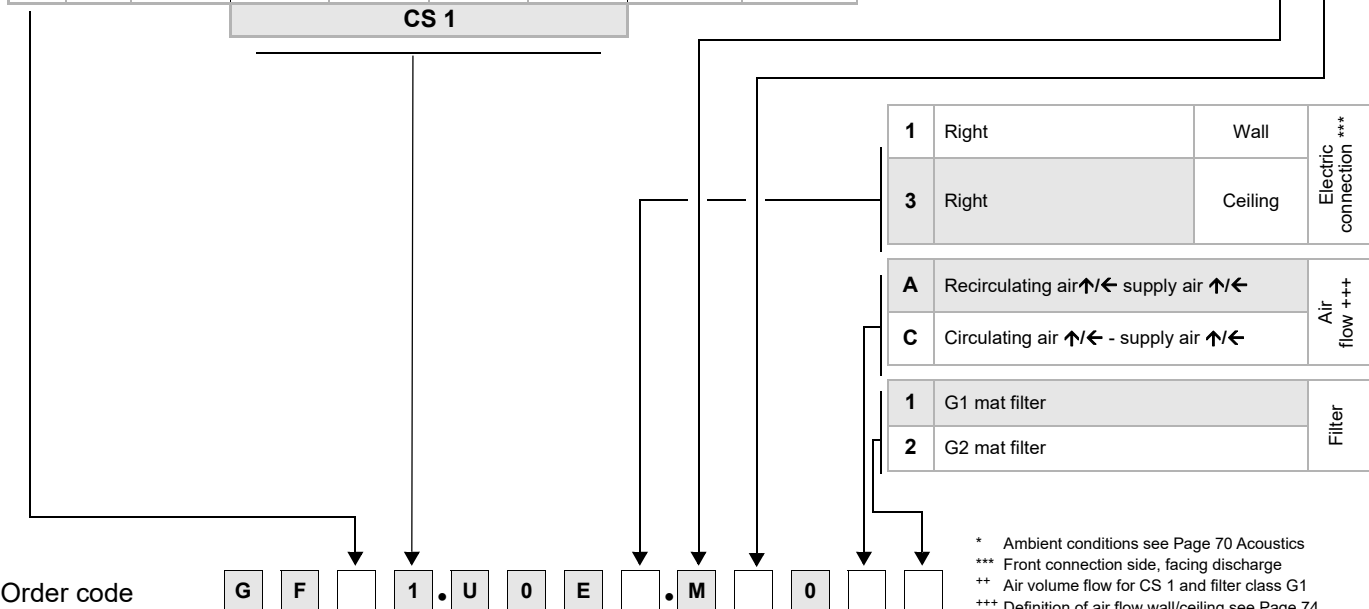

\* Ambient conditions see Page 70 Acoustics  
 \*\*\* Front connection side, facing discharge  
 \*\* Air volume flow for CS 1 and filter class G1  
 \*\*\* Definition of air flow wall/ceiling see Page 74

Accessories					Variant		Type	Code		
	Vertical wall/horizontal ceiling	A	Aluminium rigid	C	013		Discharge plenum primary air connection DN100	not insulated	A	012
	Vertical wall/horizontal ceiling	C	Aluminium rigid	C	033		Discharge bend	not insulated	A	052
	Vertical wall/horizontal ceiling; with unit foot cover **	A	Aluminium rigid	C	053		Discharge telescopic connection	not insulated	A	152
	Vertical wall/horizontal ceiling; with unit foot cover and intake front grille **	A	Aluminium rigid	C	073		Air intake plenum with primary air connection DN 125	not insulated	A	011
	Horizontal ceiling; closed on rear side	C	Aluminium rigid	C	133		Air intake bend	not insulated	A	051
	Vertical stand-alone installation closed on rear side	C	Aluminium rigid	C	233		Transition piece for intake telescopic connection		A	131
** Unit feet ZGF.0A913 required							Intake telescopic connection (transition piece required)	not insulated	A	151
							Unit feet for recirculating-air units *		A	913
							Spare filter (5 pieces)	G1	A	813
								G2		823

<b>Sizes 1 to 8</b> * 0, if irrespective of size	<b>Order code</b>	Z	G	F	.					

Full electric heating, model sizes 1 to 8

**FläktGroup MATRIX 2000**

not applicable

**FläktGroup MATRIX 4000**

**System features MATRIX 4000:**

- Temperature assignment.: 7...40 °C (default 10..30 °C)
- Assignment of speed stage
- Adjustable regulating range
- Change-over between normal/economy mode on control panel
- Input for change-over between normal/economy mode or unit OFF with frost protection
- Room temperature measurement using control panel
- External room temperature sensor can be connected
- Temperature control via fan
- Room frost protection
- Status messages using LED
- Status and alarm signal via volt free change-over contacts
- Unit individual and group control
- Isolation of individual units in case of fault
- Motor temperature monitoring (TC required)
- Network-enabled
- Summer / winter compensation
- Stand alone unit control
- Inputs for operating mode:
  - Normal mode
  - Economy mode
  - Autonomous mode
  - Unit OFF
- Regulation of multi-stage electrical heating with disconnection in case of over-temperature
- Motor temperature monitoring (with speed stage motors TC required)

**MATRIX OP30C**

Control panel for MATRIX 4000

- Pure white casing, protection type IP20
- Setpoint temperature setting
- Speed stage selection switch 0-A(Auto)-1-2-3
- LEDs for operation/fault/ext.control
- Integrated room temperature sensor

**MATRIX OP31C**

As for control panel OP30C, but also with:

- Normal/economy mode buttons

**MATRIX OP50C**

Control panel for MATRIX 4000

- Pure white casing, protection type IP20
- Menu-guided controls using rotation navigator
- LCD display with plain-text display
- Status messages using pictograms
- Integrated room temperature sensor

**MATRIX OP51C**

As for control panel OP50C, but also with:

- Integrated weekly clock timer with holiday and special days programme

**MATRIX.IR**

Infrared remote control for control system MATRIX 4000

- Black casing, RAL 9004
- LCD display approx. 45x30 mm
- Function as in OP44C (without status, alarm and external control signals, no integrated room temperature sensor)
- Maximum range 20 m
- Speed stage selection switch 0-A(Auto)-1-2-3

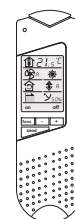
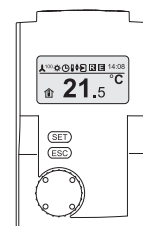
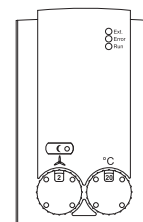
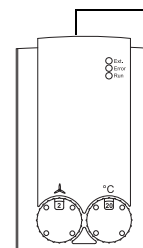

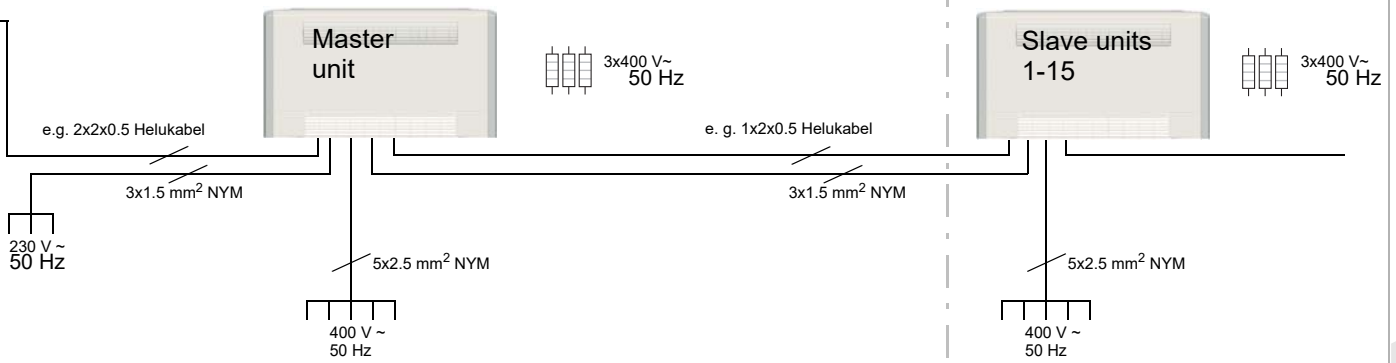

Speeds	Stand alone unit control with operating and Fault signal	Input unit OFF with room frost protection	Input economy contact	Contact heat request	Connection external sensor	
up to 3 speed	•	•			•	1
	•		•		•	2
	•	•	•	•	•	3

- 1
- 2
- 3

Without return air sensor *	2
With return air sensor *	7
Control panel	
Enclosed control panel	A
Integrated control panel	B

**Order code**

D 4 . 0 [ ] [ ] . [ ] [ ]

Master unit

D 4 . 0 [ ] [ ] . Z D

Slave unit

\* Alternatively room temperature sensor (see Page 99)

# Recirculating-Air Unit Cooling

## 2-pipe chilled water

CWP 6/12 °C  
 t<sub>L1</sub> = +27 °C  
 φ<sub>1</sub> = 46 % r.h.

Flex-Geko

Sizes 1 to 8

Model size	Speeds	Air volume m <sup>3</sup> /h	Capacity stage 1				Capacity stage 2				Capacity stage 3				AC-motor		EC motor	
			Cooling capacity	Pressure drop	Heating capacity	Pressure drop	Cooling capacity	Pressure drop	Heating capacity	Pressure drop	Cooling capacity	Pressure drop	Heating capacity	Pressure drop	Sound power	Sound pressure *	Sound power	Sound pressure *
			Q <sub>K</sub> kW	Δp <sub>K</sub> kPa	Q <sub>H</sub> kW	Δp <sub>H</sub> kPa	Q <sub>K</sub> kW	Δp <sub>K</sub> kPa	Q <sub>H</sub> kW	Δp <sub>H</sub> kPa	Q <sub>K</sub> kW	Δp <sub>K</sub> kPa	Q <sub>H</sub> kW	Δp <sub>H</sub> kPa	dB(A)	dB(A)	dB(A)	dB(A)
1	1	150	1.0	5.8	-	-	1.0	1.9	-	-	1.2	2.2	-	-	30	21	28	< 20
	2	220	1.2	9.2	-	-	1.4	3.4	-	-	1.6	4.1	-	-	36	28	37	28
	3	270	1.4	11.4	-	-	1.7	4.6	-	-	1.9	5.5	-	-	42	33	42	33
	4	350	1.6	14.9	-	-	1.9	6.2	-	-	2.3	8.1	-	-	48	39	48	39
	5	530	2.0	21.9	-	-	2.5	9.9	-	-	3.0	13.0	-	-	58	50	58	50
2	1	160	1.2	10.8	-	-	1.3	3.6	-	-	1.3	1.1	-	-	28	< 20	28	< 20
	2	230	1.5	17.7	-	-	1.7	6.2	-	-	1.7	1.7	-	-	35	26	36	27
	3	280	1.7	22.1	-	-	2.0	8.3	-	-	2.0	2.5	-	-	42	33	41	32
	4	360	2.0	29.1	-	-	2.4	11.1	-	-	2.5	3.7	-	-	46	37	47	38
	5	540	-	-	-	-	3.1	18.4	-	-	3.4	6.4	-	-	58	49	58	49
3	1	280	1.7	5.5	-	-	2.1	3.5	-	-	2.2	3.5	-	-	30	21	30	22
	2	350	2.0	7.2	-	-	2.5	4.9	-	-	2.7	4.9	-	-	35	27	36	27
	3	470	2.4	10.0	-	-	3.1	7.4	-	-	3.4	7.6	-	-	43	34	43	34
	4	670	3.0	14.7	-	-	3.9	11.2	-	-	4.4	12.2	-	-	52	44	52	43
	5	890	3.4	19.1	-	-	4.5	15.1	-	-	5.3	17.5	-	-	59	51	59	50
4	1	290	2.0	7.8	-	-	2.3	5.1	-	-	2.4	2.6	-	-	29	20	29	20
	2	360	2.3	10.4	-	-	2.8	6.9	-	-	2.9	3.7	-	-	35	26	34	25
	3	490	2.8	15.0	-	-	3.5	10.5	-	-	3.7	5.9	-	-	41	32	41	33
	4	720	3.5	22.6	-	-	4.5	17.2	-	-	5.0	10.0	-	-	51	42	51	42
	5	990	4.1	30.8	-	-	5.5	24.4	-	-	6.2	15.1	-	-	58	50	59	50
5	1	300	2.1	10.4	-	-	2.6	6.8	-	-	2.6	3.5	-	-	28	20	28	< 20
	2	370	2.5	13.9	-	-	3.0	9.3	-	-	3.1	4.9	-	-	34	25	33	24
	3	520	3.2	21.3	-	-	3.9	14.7	-	-	4.2	8.2	-	-	42	34	41	33
	4	740	3.9	31.5	-	-	5.0	23.0	-	-	5.4	13.3	-	-	51	42	51	42
	5	1010	4.7	43.0	-	-	6.1	33.4	-	-	6.7	19.5	-	-	59	51	59	51
6	1	430	2.6	2.7	-	-	3.0	1.7	-	-	3.1	0.9	-	-	33	24	33	24
	2	560	3.1	3.9	-	-	3.8	2.6	-	-	3.7	1.2	-	-	39	31	40	31
	3	750	3.8	5.4	-	-	4.8	4.0	-	-	5.0	2.1	-	-	46	38	47	38
	4	990	4.4	7.3	-	-	5.7	5.6	-	-	6.3	3.2	-	-	55	47	54	46
	5	1310	5.2	9.8	-	-	6.8	7.6	-	-	7.6	4.5	-	-	62	54	62	53
7	1	460	2.9	3.7	-	-	3.5	2.4	-	-	3.4	1.1	-	-	33	24	33	24
	2	580	3.5	5.0	-	-	4.2	3.4	-	-	4.3	1.7	-	-	38	30	39	30
	3	770	4.2	7.1	-	-	5.2	5.0	-	-	5.5	2.7	-	-	46	38	46	37
	4	1030	5.0	9.8	-	-	6.4	7.3	-	-	6.8	4.1	-	-	54	45	54	45
	5	1420	5.9	13.4	-	-	7.8	10.6	-	-	8.7	6.3	-	-	62	53	62	54
8	1	590	3.7	6.2	-	-	4.4	4.0	-	-	4.4	2.0	-	-	34	25	34	26
	2	690	4.2	7.7	-	-	5.0	5.1	-	-	5.2	2.7	-	-	38	29	38	29
	3	970	5.2	11.3	-	-	6.4	7.9	-	-	6.8	4.4	-	-	46	37	46	37
	4	1380	6.3	16.3	-	-	8.2	12.6	-	-	8.9	7.1	-	-	55	46	54	46
	5	1820	7.3	21.1	-	-	9.6	16.9	-	-	10.8	10.1	-	-	61	53	61	53

Motor design		
AC motor	TC integr.	0
	TC led out	1
EC motor		E

Plastic terminal box (with MATRIX metal sheet electrical control box)



Speed combination

1-2-3 <sup>+</sup>	A
2-3-4 <sup>+</sup>	B
3-4-5 <sup>+</sup>	C
1-3-5 <sup>+</sup>	E
1-2-3-4-5 <sup>+</sup>	H
Min..Max (EC motor)	F

Metal sheet electric control box with terminal strip or for integ. Controls



Speed combination

1-2-3 <sup>+</sup>	K
2-3-4 <sup>+</sup>	L
3-4-5 <sup>+</sup>	M
1-3-5 <sup>+</sup>	O
1-2-3-4-5 <sup>+</sup>	R
Min..Max (EC motor)	S

Data for capacity stage 4 (CS 4) are available on request (see Page 11).

1	Left	Wall	Medium connect.***
2	Right		
3	Left	Ceiling	
4	Right		
0	With drainage	Condensate line	
1	With condensate pump		
A	Circulating air ↗↖ supply air ↗↖	Air flow +++	
B	Circulating air ↗↖ - supply air ↘↙**		
C	Circulating air ↘↙ - supply air ↗↖		
D	Circulating air ↘↙ - supply air ↘↙**		
1	G1 mat filter	Filter	
2	G2 mat filter		
3	G2 mat filter		

\* Ambient conditions see Page 70 Acoustics  
 \*\* Only wall units  
 \*\*\* Front connection side, facing discharge  
 + only AC motor  
 \*\* Air volume flow for CS 1 and filter class G1  
 \*\*\* Definition of air flow wall/ceiling see Page 74

Order code

G F . U W 0 . . . . .



2-pipe system chilled water, model sizes 1 to 8

### Accessories

Arrangement/ installation	Variant/ unit casing	Suitable for air flow designation	Discharge grille	Code
	Vertical wall/ horizontal ceiling	A	Plastic adjustable	C 012
			Aluminium rigid	C 013
	Vertical wall	B	Plastic adjustable	C 022
			Aluminium rigid	C 032
	Vertical wall/ horizontal ceiling	C	Plastic adjustable	C 032
			Aluminium rigid	C 033
	Vertical wall	D	Plastic adjustable	C 042
			Aluminium rigid	C 052
	Vertical wall/ horizontal ceiling; with unit foot cover **	A	Plastic adjustable	C 052
			Aluminium rigid	C 053
	Vertical wall; with unit foot cover **	B	Plastic adjustable	C 062
			Aluminium rigid	C 072
	Vertical wall/ horizontal ceiling; with unit foot cover and intake front grille **	A	Plastic adjustable	C 072
			Aluminium rigid	C 073
	Vertical wall, with unit foot cover and intake front grille **	B	Plastic adjustable	C 082
			Aluminium rigid	C 132
	Horizontal ceiling; closed rear side	C	Plastic adjustable	C 132
			Aluminium rigid	C 133
	Vertical stand-alone installation closed on rear side	C	Plastic adjustable	C 232
			Aluminium rigid	C 233

Variant	Type	Code
Discharge plenum primary air connection DN100	insulated	A 022
Discharge plenum with round fitting DN200	insulated	A 042
Discharge bend	insulated	A 062
Flexible canvas discharge connector		A 112
Discharge sound attenuator connector		A 212
Geko-Drive – motorized regulated discharge profile ***	Left	A 412
	Right	A 422
Air intake plenum with primary air connection DN 125	not insulated	A 011
Air intake plenum with round connection DN 200	not insulated	A 031
Air intake bend	not insulated	A 051
Intake flexible connection (transition piece required)		A 111
Transition piece for intake flexible connection, telescopic and sound-attenuator connection		A 131
Intake telescopic connection (transition piece required)	not insulated	A 151
Intake sound attenuator connection for recirculating-air unit (transition piece required)		A 211
Seal cap for round fitting, DN 200 *	insulated	A 713
Unit feet for recirculating-air units *	G1	A 813
	G2	A 823
	G3	A 833
Spare filter (5 pieces)		

\*\* Unit feet ZGF.0A913 required

\*\*\* Note! Geko-Drive only together with unit casing!

**Order code** Z G F . [ ] [ ] [ ] [ ] [ ]

**Sizes 1 to 8**  
\* 0, if irrespective of size

### Valves

MATRIX 500	MATRIX 2000	MATRIX 3000/4000	Terminal box	Drive	Operating voltage/circuit	
•	•	•	•	2-point open/close	230 V AC <sup>2)</sup>	T
	•	•	•		24 V AC <sup>1), 2)</sup>	Q
	•	•	•	3-point open/stop/close	230 V AC	R
		•	•		24 V AC <sup>1)</sup>	N
		•	•		230 V AC + 2 contacts	C
			•	Continuous	0/2 ... 10 V = 24 V AC <sup>1)</sup>	S

Connection/shut-off		Medium connection	
Inlet/outlet flow with outside thread	0	Left	L
Inlet/outlet with solder fitting	1	Right	R
Inlet/outlet + ball trap with external thread	2		
Inlet/outlet + ball trap with solder fitting	3		
Inlet + ball trap/ outlet + shut-off valve with external thread	4		
Inlet + ball trap/ outlet + shut-off valve with solder fitting	5		

k <sub>vs</sub> values Cooling	
0.25	≡ 03
0.40	≡ 04
0.63	≡ 06
1.00	≡ 10
1.60 <sup>2)</sup>	≡ 16
2.50 <sup>2)</sup>	≡ 25
4.00	≡ 40

**Order code** V G F . [ ] [ ] [ ] [ ] [ ] [ ] [ ] [ ] [ ] [ ]

**Cooling circuit**

<sup>1)</sup> 24 V-transformer to be provided by others

<sup>2)</sup> k<sub>vs</sub>-values for open/close actuators (T,Q) only k<sub>vs</sub> 1.6 and 2.5 possible

### FläktGroup MATRIX 2000

#### System features MATRIX 500/2000:

- Extended temperature assignment.: 7...40 °C (default 10...30 °C)
- Manual assignment of speed stage
- Adjustable regulating range
- Change-over between normal/economy mode on control panel
- Room temperature measurement using control panel
- External room temperature sensor can be connected
- Valve control (2-point)
- Temperature control via fan speed change and valve(s)
- Status messages using LED
- Group control
- Group switch-off switch-off in case of fault
- Motor temperature monitoring (TC required)
- Network-enabled

#### MATRIX OP21C

- Control panel for MATRIX 2000
- Pure white casing, protection type IP20
  - Setpoint temperature setting
  - Speed stage selection switch 0-A (Auto)-1-2-3
  - Economy mode button
  - LEDs for operation/fault/ext.control
  - Integrated room temperature sensor

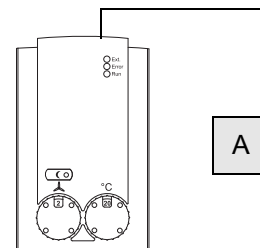

### FläktGroup MATRIX 3000/4000

#### System features MATRIX 3000:

- Temperature assignment.: 7...40 °C (default 10...30 °C)
- Speed (stage) assignment
- Adjustable regulating range
- Change-over between normal/economy mode on control panel
- Input for change-over between normal/economy mode or unit OFF with frost protection
- Room temperature measurement using control panel
- External room temperature sensor can be connected
- Valve control (2x2 or 2x3 point)
- Temperature control via fan and/or valve(s)
- Room frost protection
- Status messages using LED
- Status and fault signals using floating change-over contacts
- Unit individual and group control
- Isolation of individual units in case of fault
- Motor temperature monitoring (with speed stage motors TC required)
- Network-enabled

#### MATRIX OP30C

- Control panel for MATRIX 3000/4000
- Pure white casing, protection type IP20
  - Setpoint temperature setting
  - Speed-stage selection switch 0-A(Auto)-1-2-3-4-5 (depends on motor type, with EC motor up to 5 stages)
  - LEDs for operation/fault/ext.control
  - Integrated room temperature sensor

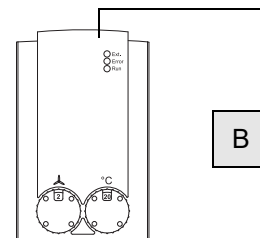

#### MATRIX OP31C

- As for control panel OP30C, but also with:
- Normal/economy mode buttons

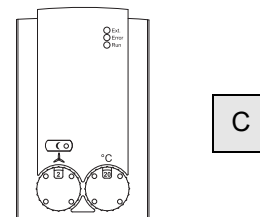

#### MATRIX OP44C

- As for control panel OP31C, but also with button for:
- Changeover between recirculating-air/ mixed-air operation
  - Change-over heating/cooling/automatic mode

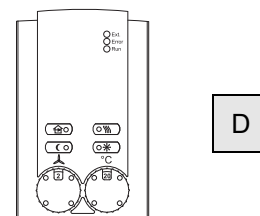

#### MATRIX OP50C

- Control panel for MATRIX 3000
- Pure white casing, protection type IP20
  - Menu-guided controls using rotation navigator
  - LCD display with plain-text display
  - Status messages using pictograms
  - Integrated room temperature sensor
  - Continuous speed regulation (only together with EC motor)

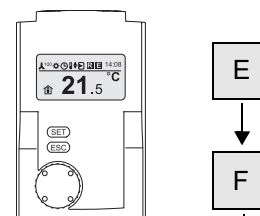

#### MATRIX OP51C

- As for control panel OP50C, but also with:
- Integrated weekly clock timer with a holiday and special days programme

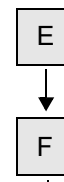

#### MATRIX.IR

- Infrared remote control for MATRIX 3000
- Black casing, RAL 9004
  - LCD display approx. 45x30 mm
  - Function as in OP44C (without status, fault and external control signals, no integrated room temperature sensor)
  - Maximum range 20 m
  - Speed-stage selection switch 0-A(Auto)-1-2-3-4-5 (depends on motor type, with EC motor up to 5 stages)



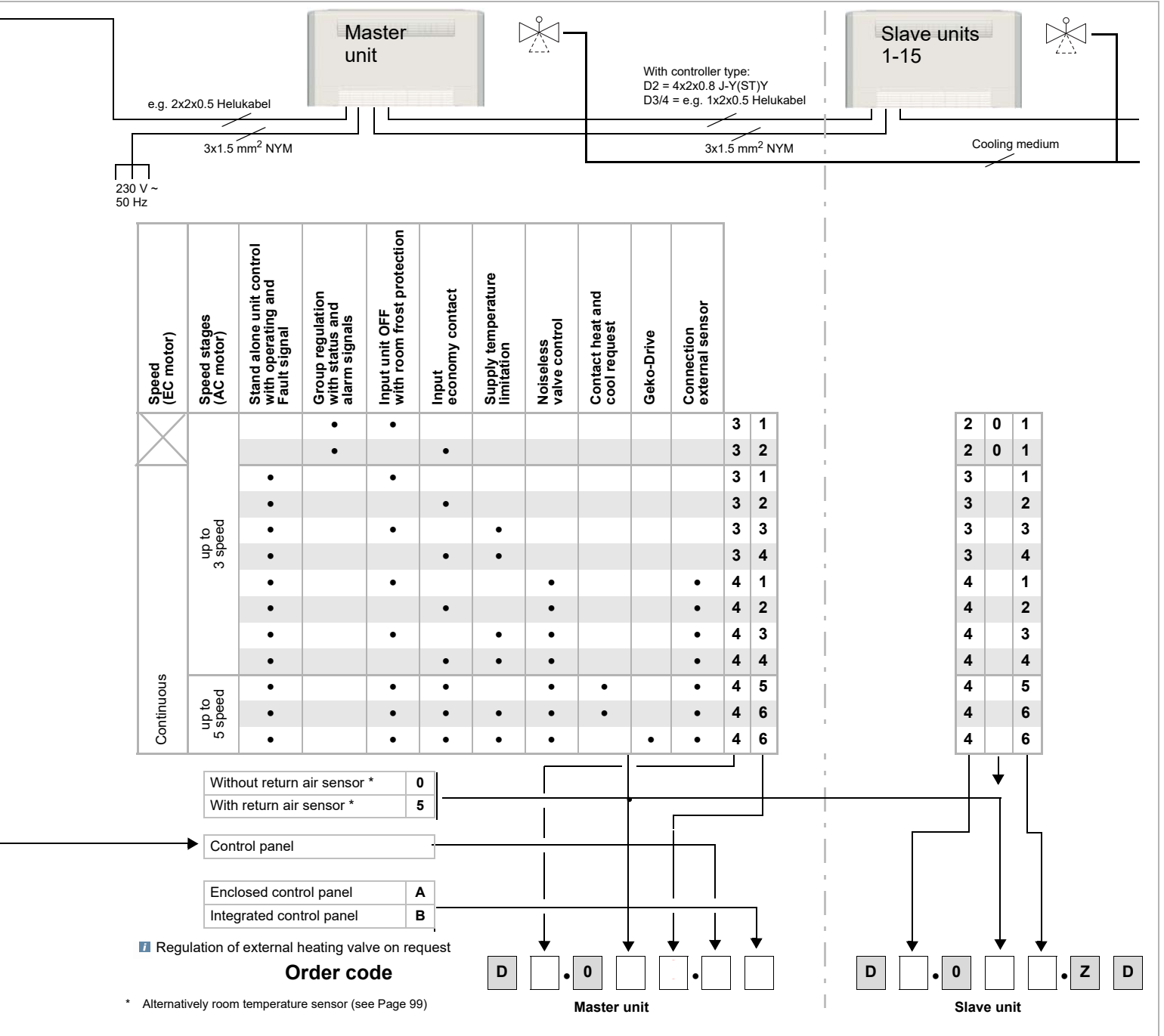
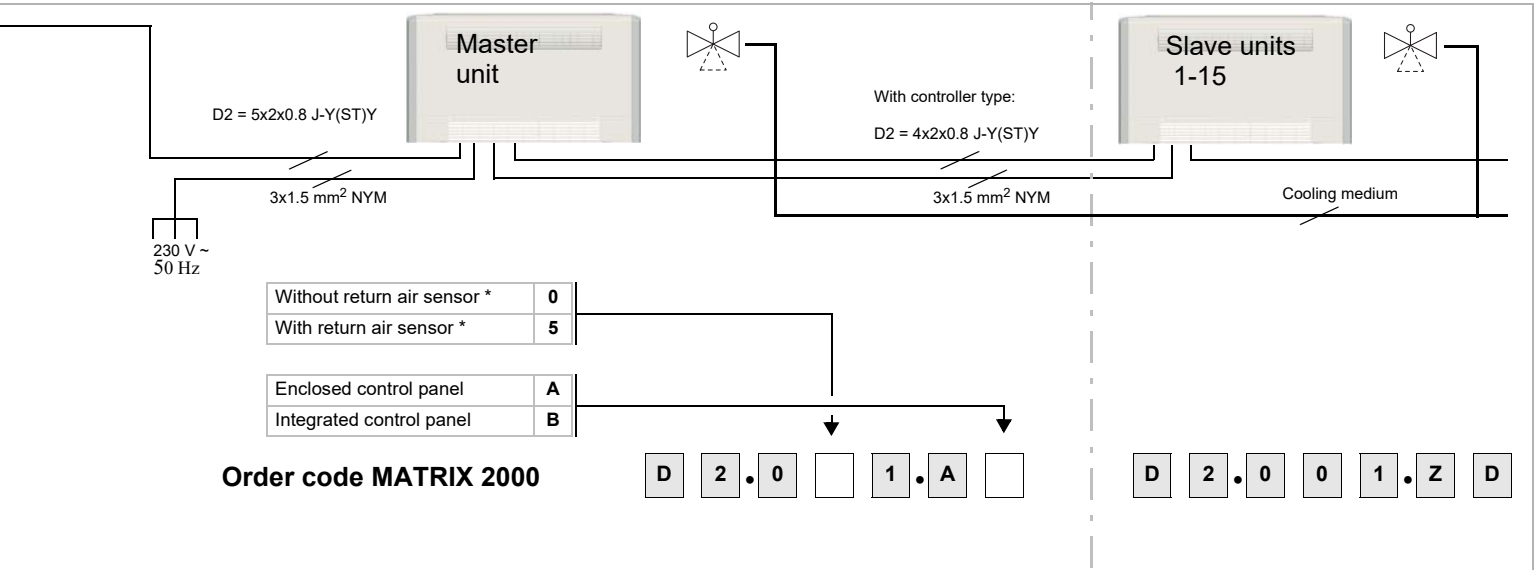

# Recirculating-Air Unit Cooling

## Direct evaporator

Flex-Geko

Sizes 1 to 8

$t_o = 10\text{ }^\circ\text{C}$  Refrigerant:  
 $t_{L1} = +27\text{ }^\circ\text{C}$  R410A  
 $\phi_1 = 46\text{ \% r.h.}$

Model size	Speeds	Air volume m <sup>3</sup> /h	Capacity stage 1			AC motor		EC motor	
			Cooling capacity Q <sub>K</sub> kW	Heating capacity Q <sub>H</sub> kW	Pressure drop Δp <sub>H</sub> kPa	Sound power dB(A)	Sound pressure* dB(A)	Sound power dB(A)	Sound pressure* dB(A)
1	1	-	-	-	-	-	-	-	-
	2	-	-	-	-	-	-	-	-
	3	270	1.2	-	-	42	33	42	33
	4	350	1.4	-	-	48	39	48	39
	5	530	1.7	-	-	58	50	58	50
2	1	-	-	-	-	-	-	-	-
	2	-	-	-	-	-	-	-	-
	3	280	1.4	-	-	42	33	41	32
	4	360	1.7	-	-	46	37	47	38
	5	540	2.3	-	-	58	49	58	49
3	1	-	-	-	-	-	-	-	-
	2	-	-	-	-	-	-	-	-
	3	470	2.5	-	-	43	34	43	34
	4	670	3.1	-	-	52	44	52	43
	5	890	3.7	-	-	59	51	59	50
4	1	-	-	-	-	-	-	-	-
	2	-	-	-	-	-	-	-	-
	3	490	2.4	-	-	41	32	41	33
	4	720	2.9	-	-	51	42	51	42
	5	990	3.6	-	-	58	50	59	50
5	1	-	-	-	-	-	-	-	-
	2	-	-	-	-	-	-	-	-
	3	520	2.6	-	-	42	34	41	33
	4	740	3.4	-	-	51	42	51	42
	5	1010	4.2	-	-	59	51	59	51
6	1	-	-	-	-	-	-	-	-
	2	-	-	-	-	-	-	-	-
	3	750	3.8	-	-	46	38	47	38
	4	990	4.6	-	-	55	47	54	46
	5	1310	5.6	-	-	62	54	62	53
7	1	-	-	-	-	-	-	-	-
	2	-	-	-	-	-	-	-	-
	3	770	4.2	-	-	46	38	46	37
	4	1030	5.2	-	-	54	45	54	45
	5	1420	6.4	-	-	62	53	62	54
8	1	-	-	-	-	-	-	-	-
	2	-	-	-	-	-	-	-	-
	3	970	4.6	-	-	46	37	46	37
	4	1380	5.9	-	-	55	46	54	46
	5	1820	7.1	-	-	61	53	61	53

Motor design		
AC motor	TC integr.	0
	TC led out	1
EC motor		E

Metal sheet electric control box with terminal block or for integ. Controls



Speed combination

3-4-5	M
Min..Max (EC motor)	S

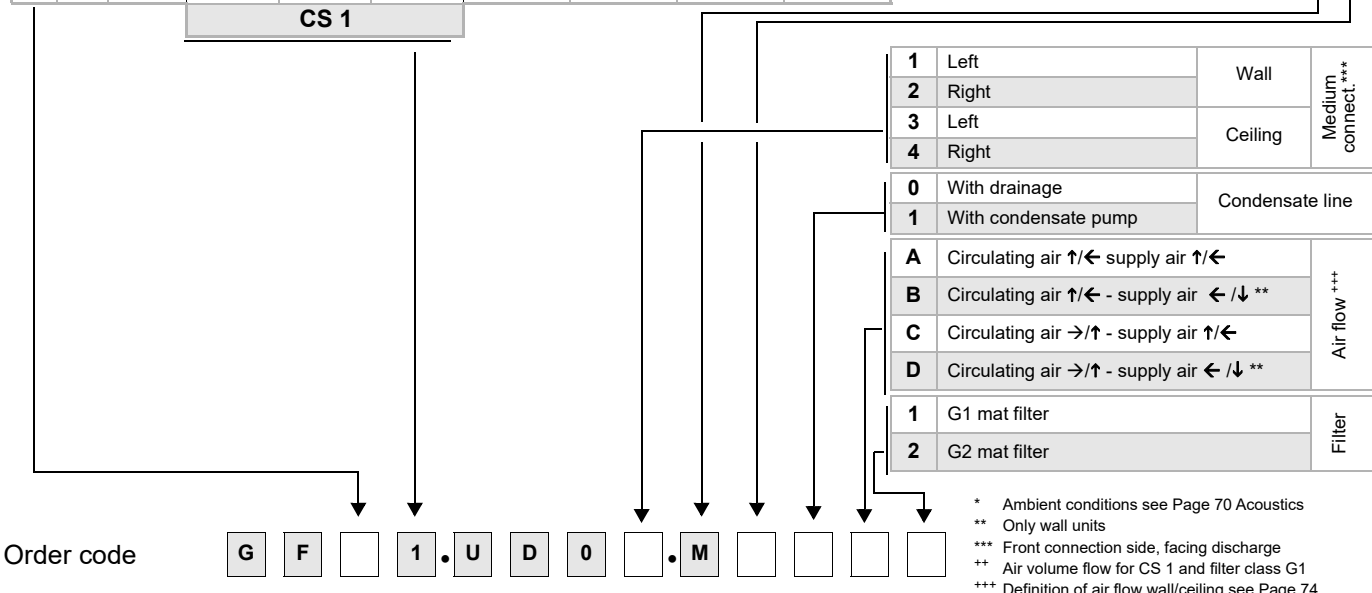

\* Ambient conditions see Page 70 Acoustics  
 \*\* Only wall units  
 \*\*\* Front connection side, facing discharge  
 \*\* Air volume flow for CS 1 and filter class G1  
 \*\*\* Definition of air flow wall/ceiling see Page 74

### Accessories

Arrangement/ installation	Variant/ unit casing	Suitable for air flow designation	Discharge grille	Code	Variant	Type	Code
	Vertical wall/ horizontal ceiling	A	Plastic adjustable	C 012		insulated	A 022
			Aluminium rigid	C 013			
	Vertical wall	B	Plastic adjustable	C 022		insulated	A 062
	Vertical wall/ horizontal ceiling	C	Plastic adjustable	C 032		not insulated	A 112
			Aluminium rigid	C 033			
	Vertical wall	D	Plastic adjustable	C 042		Left	A 412
						Right	A 422
	Vertical wall/ horizontal ceiling; with unit foot cover **	A	Plastic adjustable	C 052		not insulated	A 011
			Aluminium rigid	C 053			
	Vertical wall; with unit foot cover **	B	Plastic adjustable	C 062		not insulated	A 051
	Vertical wall/ horizontal ceiling; with unit foot cover and intake front grille **	A	Plastic adjustable	C 072		not insulated	A 111
			Aluminium rigid	C 073			
	Vertical wall, with unit foot cover and intake front grille **	B	Plastic adjustable	C 082		not insulated	A 131
	Horizontal ceiling; closed rear side	C	Plastic adjustable	C 132		not insulated	A 151
			Aluminium rigid	C 133			
	Vertical stand-alone installation closed on rear side	C	Plastic adjustable	C 232		not insulated	A 913
			Aluminium rigid	C 233			
						G1	A 813
						G2	A 823

\*\* Unit feet ZGF.0A913 required

**Sizes 1 to 8**  
\* 0, if irrespective of size

**Order code** Z G F . [ ] [ ] [ ] [ ] [ ]

\*\*\* Note! Geko-Drive only together with unit casing!

### Valves

Expansion valve R410 A

Setting of expansion valve ≡ S1-S8

Medium connection	
Left	L
Right	R

**Order code** V G F . E 0 [ ] [ ] . 0 [ ]

Cooling circuit

**FläktGroup MATRIX 2000**

not applicable

**FläktGroup MATRIX 3000/4000**

**System features MATRIX 3000:**

- Temperature assignment.: 7...40 °C (default 10..30 °C)
- Speed (stage) assignment
- Adjustable regulating range
- Change-over between normal/economy mode on control panel
- Input for change-over between normal/economy mode or unit OFF with frost protection
- Room temperature measurement using control panel
- External room temperature sensor can be connected
- Temperature control via fan
- Status messages using LED
- Status and alarm signal via volt free change-over contacts
- Unit individual and group control
- Isolation of individual units in case of fault
- Motor temperature monitoring (with speed stage motors TC required)
- Network-enabled

**Additional features MATRIX 4000:**

- Summer compensation
- Stand alone unit control
- Inputs for operating mode:
  - Normal mode
  - Economy mode
  - Autonomous mode
  - Unit OFF

**MATRIX OP30C**

Control panel for MATRIX 3000/4000

- Pure white casing, protection type IP20
- Setpoint temperature setting
- Speed-stage selection switch 0-A(Auto)-1-2-3-4-5 (depends on motor type, with EC motor up to 5 stages)
- LEDs for operation/fault/ext.control
- Integrated room temperature sensor

**MATRIX OP31C**

As for control panel OP30C, but also with:

- Normal/economy mode buttons

**MATRIX OP50C**

Control panel for MATRIX 3000/4000

- Pure white casing, protection type IP20
- Menu-guided controls using rotation navigator
- LCD display with plain-text display
- Status messages using pictograms
- Integrated room temperature sensor
- Continuous speed assignment (only in connection with EC motor)

**MATRIX OP51C**

As for control panel OP50C, but also with:

- Integrated weekly clock timer with holiday and special days programme

**MATRIX.IR**

Infrared remote control for control system  
MATRIX 3000/4000

- Black casing, RAL 9004
- LCD display approx. 45x30 mm
- Function as in OP44C (without status, alarm and external control signals, no integrated room temperature sensor)
- Maximum range 20 m
- Speed-stage selection switch 0-A(Auto)-1-2-3-4-5 (depends on motor type, with EC motor up to 5 stages)

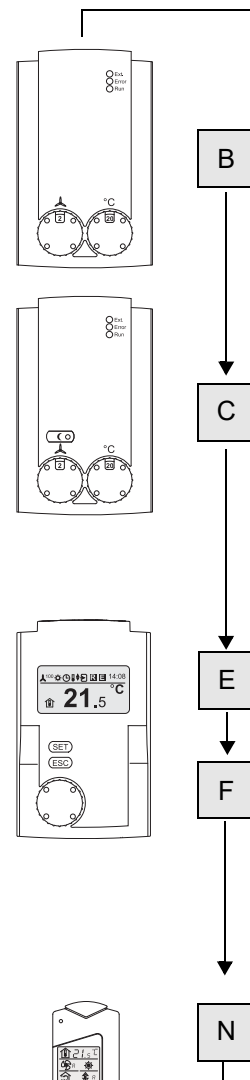

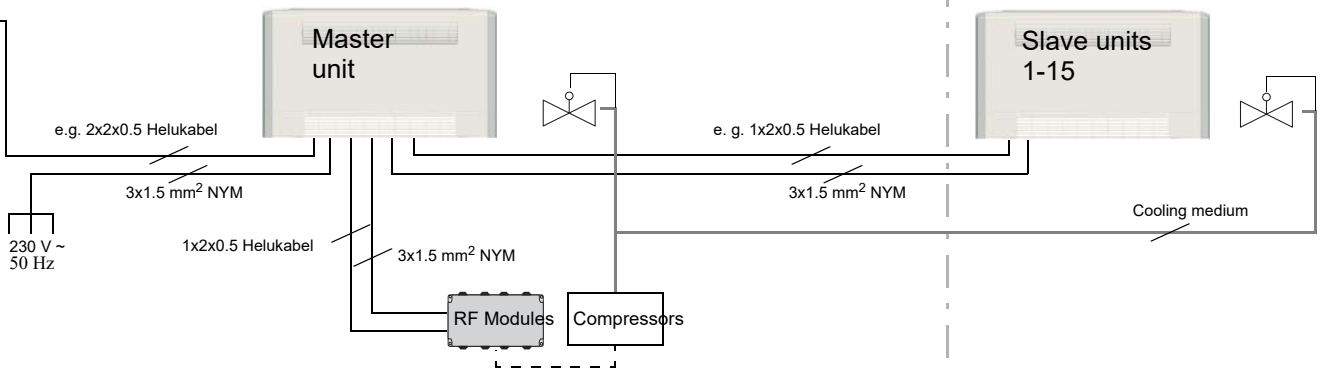

Speeds EC motor	Speed stages AC motor	Stand alone unit control with operating and Fault signal	Input unit OFF	Input economy contact	Connection external sensor		
Continuous	up to 3 speed	•	•			3	1
		•		•		3	2
		•	•		•	4	1
		•		•	•	4	2
		•	•	•	•	4	5

Without return air sensor *	4
With return air sensor *	9

Control panel	
Enclosed control panel	A
Integrated control panel	B

7 Regulation of external heating valve on request

**Order code**

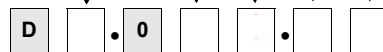

Master unit

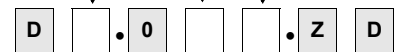
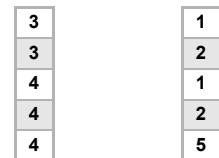

Slave unit

\* Alternatively room temperature sensor (see Page 99)

# Mixed-Air Unit Heating and Cooling

## 4-pipe chilled and warm water

Flex-Geko

Sizes 1 to 8

CWP 6/12 °C    PWW 70/50 °C  
 $t_{L1} = +27$  °C     $t_{L1} = +10$  °C  
 $\phi_1 = 46$  % r.h.

Model size	Speeds	Air volume m <sup>3</sup> /h	Capacity stage 1				Capacity stage 2				AC-motor		EC motor	
			Q <sub>K</sub> • Cooling capacity kW	Δp <sub>K</sub> Pressure drop kPa	Q <sub>H</sub> • Heating capacity kW	Δp <sub>H</sub> Pressure drop kPa	Q <sub>K</sub> • Cooling capacity kW	Δp <sub>K</sub> Pressure drop kPa	Q <sub>H</sub> • Heating capacity kW	Δp <sub>H</sub> Pressure drop kPa	Sound power dB(A)	Sound pressure* dB(A)	Sound power dB(A)	Sound pressure* dB(A)
1	1	145	0.9	6.3	1.0	0.2	0.9	1.3	1.0	0.2	30	21	30	21
	2	210	1.2	9.8	1.2	0.3	1.3	2.2	1.4	0.4	36	28	39	30
	3	265	1.4	12.7	1.4	0.3	1.5	3.0	1.5	0.5	42	33	44	35
	4	340	1.6	16.3	1.6	0.4	1.8	4.2	1.8	0.6	48	39	50	41
	5	490	1.9	23.0	1.9	0.6	2.2	6.3	2.1	0.8	58	50	59	50
2	1	150	1.0	1.8	1.3	0.4	1.2	2.3	1.3	0.5	28	< 20	28	< 20
	2	220	1.3	3.1	1.6	0.6	1.6	4.0	1.7	0.7	35	26	37	28
	3	275	1.5	4.2	1.9	0.8	1.9	5.7	2.0	0.9	42	33	43	34
	4	350	1.8	5.6	2.1	1.0	2.3	8.0	2.3	1.2	46	37	49	40
	5	515	2.2	8.4	2.6	1.4	2.9	12.7	2.8	1.8	58	49	59	50
3	1	250	1.7	5.8	2.1	1.1	1.8	2.2	2.1	1.3	30	21	31	22
	2	315	1.9	7.7	2.3	1.4	2.1	3.0	2.4	1.6	35	27	36	28
	3	430	2.4	11.1	2.8	2.0	2.7	4.9	2.9	2.3	43	34	44	35
	4	615	2.9	16.2	3.4	2.8	3.5	7.6	3.6	3.3	52	44	53	44
	5	800	3.3	20.9	3.8	3.4	4.1	10.3	4.1	4.2	59	51	59	50
4	1	270	1.9	8.5	2.4	1.8	2.1	3.4	2.4	1.9	29	20	31	22
	2	335	2.2	11.5	2.7	2.2	2.4	4.6	2.8	2.5	35	26	35	27
	3	460	2.8	16.9	3.3	3.1	3.1	7.2	3.4	3.6	41	32	43	34
	4	670	3.5	25.6	4.0	4.5	4.1	12.0	4.2	5.3	51	42	52	43
	5	910	4.1	34.5	4.7	5.9	5.0	17.0	4.9	6.9	58	50	59	51
5	1	280	1.9	3.5	2.7	2.4	2.2	4.5	2.6	2.6	28	< 20	29	21
	2	345	2.3	4.8	3.0	3.1	2.7	6.2	3.0	3.4	34	25	34	25
	3	490	3.0	7.5	3.8	4.5	3.5	10.3	3.8	5.1	42	34	42	34
	4	700	3.7	11.3	4.6	6.4	4.6	16.4	4.7	7.4	51	42	52	43
	5	945	4.4	15.3	5.3	8.4	5.6	23.8	5.6	10	59	51	60	51
6	1	405	2.8	7.3	3.6	4.8	2.6	1.1	3.3	1.1	33	24	35	26
	2	520	3.3	10.1	4.2	6.2	3.3	1.7	4.0	1.5	39	31	41	32
	3	715	4.0	14.7	5.0	8.5	4.3	2.7	4.8	2.1	46	38	49	40
	4	930	4.7	19.7	5.8	11.1	5.2	3.9	5.6	2.8	55	47	56	47
	5	1200	5.4	25.2	6.5	13.8	6.1	5.2	6.3	3.5	62	54	63	54
7	1	430	3.0	9.5	4.0	6.3	2.9	1.5	3.7	1.4	33	24	34	26
	2	545	3.6	13.3	4.6	8.1	3.6	2.2	4.3	1.8	38	30	40	31
	3	735	4.4	18.8	5.5	11.2	4.8	3.6	5.2	2.6	46	38	48	39
	4	970	5.2	25.4	6.3	14.5	5.8	5.2	6.1	3.5	54	45	55	46
	5	1310	6.1	34.3	7.3	18.9	7.1	7.3	7.2	4.7	62	53	63	55
8	1	525	3.7	14.6	4.7	9.5	3.8	2.5	4.5	2.1	34	25	35	26
	2	625	4.2	18.6	5.2	11.4	4.4	3.3	5.0	2.5	38	29	39	30
	3	880	5.2	27.8	6.4	16.4	5.7	5.3	6.1	3.7	46	37	47	38
	4	1250	6.4	40.3	7.7	22.7	7.2	8.2	7.5	5.4	55	46	55	47
	5	1625	-	-	-	-	8.6	11.2	8.5	6.9	61	53	62	53

Motor design		
AC motor	TC integr.	0
	TC led out	1
EC motor		E

Plastic terminal box (select sheet steel electric control box with MATRIX)



Speed combination

1-2-3 <sup>+</sup>	A
2-3-4 <sup>+</sup>	B
3-4-5 <sup>+</sup>	C
1-3-5 <sup>+</sup>	E
1-2-3-4-5 <sup>+</sup>	H
Min..Max (EC motor)	F

Metal-sheet electric control box with terminal block or for integrated controls



Speed combination

1-2-3 <sup>+</sup>	K
2-3-4 <sup>+</sup>	L
3-4-5 <sup>+</sup>	M
1-3-5 <sup>+</sup>	O
1-2-3-4-5 <sup>+</sup>	R
Min..Max (EC motor)	S

Data for capacity stage 3 (CS 3) are available on request (see Page 11).

Order code

G F . M W W . . . . .

1	Left	Wall	Medium connect.***
2	Right		
3	Left	Ceiling	
4	Right		
0	With drainage	Condensate pipework	
1	With condensate pump		
A	Fresh ← / ↓ - circulating → / ↑ - supply air ↑ / ←	Air flow ***	
B	Fresh ← / ↓ - circulating → / ↑ - supply air ← / ↓ **		
C	Fresh ↑ / ← - circulating → / ↑ - supply air ↑ / ←		
D	Fresh ↑ / ← - circulating → / ↑ - supply air ← / ↓ **		
1	G1 mat filter	Filter	
2	G2 mat filter		
3	G3 mat filter		

\* Ambient conditions refer to Page 70 Acoustics  
 \*\* Only wall units  
 \*\*\* Front connection side, facing discharge  
 + only AC motor  
 \*\* Air volume flow for CS 1 and filter class G1  
 \*\*\* Definition of air flow wall/ceiling see Page 74





**FläktGroup MATRIX 2000**

not applicable

**FläktGroup MATRIX 4000**

**System features MATRIX 4000:**

- Temperature assignment.: 7...40 °C (default 10..30 °C)
- Speed (stage) assignment
- Adjustable regulating range
- Change-over between normal/economy mode on control panel
- Input for change-over between normal/economy mode or unit OFF with frost protection
- Room temperature measurement using control panel
- External room temperature sensor can be connected
- Valve control (2x3 point)
- Temperature control via fan and/or valve(s)
- Room frost protection
- Status messages using LED
- Status and alarm signal via volt free change-over contacts
- Unit individual and group control
- Isolation of individual units in case of fault
- Motor temperature monitoring (with speed stage motors TC required)
- Network-enabled

**Additional features MATRIX 4000:**

- Summer / winter compensation
- Noiseless valve control
- Cool and/or heat request via volt-free contacts (related to water circuit)
- Stand alone unit control
- Inputs for operating mode:
  - Normal mode
  - Economy mode
  - Autonomous mode
  - Unit OFF
- Mixing-air damper control open/close with frost protection

**MATRIX OP30C**

Control panel for MATRIX 4000

- Pure white casing, protection type IP20
- Setpoint temperature setting
- Speed-stage selection switch 0-A(Auto)-1-2-3-4-5 (depends on motor type, with EC motor up to 5 stages)
- LEDs for operation/fault/ext.control
- Integrated room temperature sensor

**MATRIX OP31C**

As for control panel OP30C, but also with:

- Normal/economy mode buttons

**MATRIX OP44C**

As for control panel OP31C, but also with button for:

- Changeover between recirculating-air/ mixed-air operation
- Change-over heating/cooling/automatic mode

**MATRIX OP50C**

Control panel for MATRIX 4000

- Pure white casing, protection type IP20
- Menu-guided controls using rotation navigator
- LCD display with plain-text display
- Status messages using pictograms
- Integrated room temperature sensor
- Continuous speed assignment (only in connection with EC motor)

**MATRIX OP51C**

As for control panel OP50C, but also with:

- Integrated weekly clock timer with holiday and special days programme

**MATRIX.IR**

Infrared remote control for MATRIX 4000

- Black casing, RAL 9004
- LCD display approx. 45x30 mm
- Function as in OP44C (without status, alarm and external control signals, no integrated room temperature sensor)
- Maximum range 20 m
- Speed-stage selection switch 0-A(Auto)-1-2-3-4-5 (depends on motor type, with EC motor up to 5 stages)

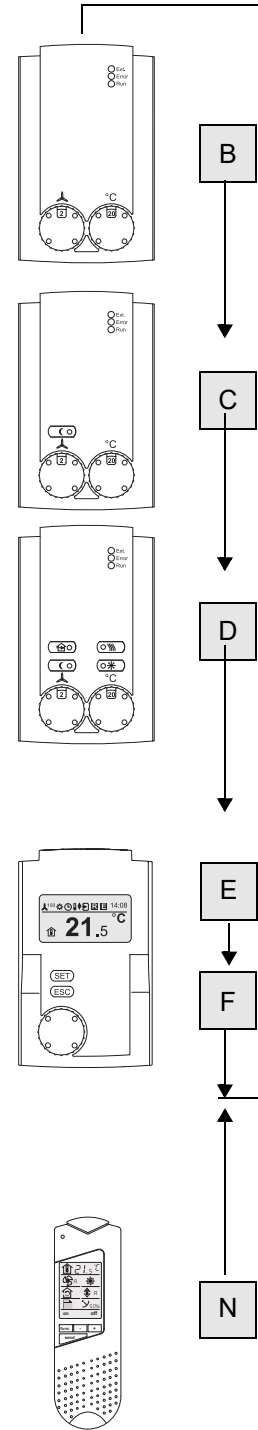

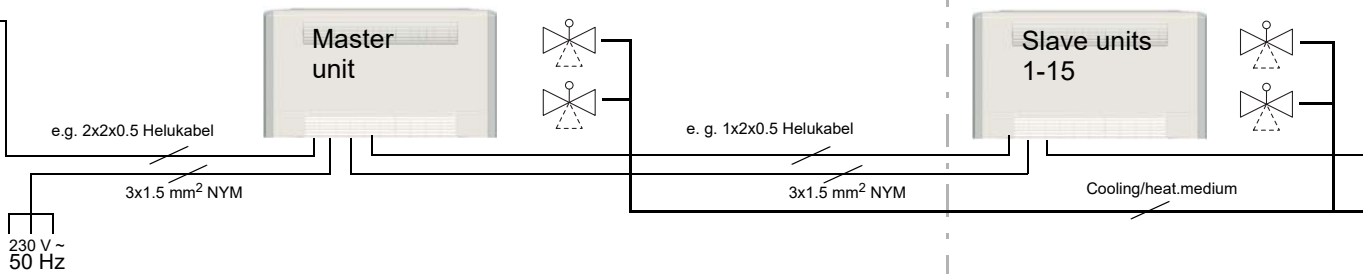

Speed (EC motor)	Speed stages (AC motor)	Stand alone unit control with operating and Fault signal	Input unit OFF with room frost protection	Input economy contact	Supply temperature limitation	Noiseless valve control	Contact heat and cool request	Geko-Drive	Connection external sensor	
Continuous	up to 3 speed	•	•	•		•			•	1
		•	•	•		•			•	2
		•	•	•	•	•			•	3
	up to 5 speed	•	•	•		•	•		•	4
		•	•	•	•	•	•		•	5
		•	•	•	•	•	•	•	•	6

without return air sensor *	0
with return air sensor *	5

Control panel	
Enclosed control panel	A
Integrated control panel	B

**Order code**

D 4 . 5 [ ] [ ] . [ ] [ ]

Master unit

- 1
- 2
- 3
- 4
- 5
- 6
- 6

D 4 . 5 [ ] [ ] . Z D

Slave unit

\* Alternatively room temperature sensor (see Page 99)

# Mixed-Air Unit Heating and Cooling

## Direct Evaporator and 2-pipe warm water

Flex-Geko

Sizes 1 to 8

$t_o = 10\text{ °C}$  Refrigerant: PWW 70/50 °C  
 $t_{L1} = +27\text{ °C}$  R410A  $t_{L1} = +10\text{ °C}$   
 $\phi_1 = 46\% \text{ r.h.}$

Model size	Speeds	Air volume m <sup>3</sup> /h	Capacity stage 1			AC motor		EC motor	
			Q <sub>K</sub> Cooling capacity kW	Q <sub>H</sub> Heating capacity kW	Pressure drop ΔP <sub>H</sub> kPa	Sound power dB(A)	Sound pressure* dB(A)	Sound power dB(A)	Sound pressure* dB(A)
1	1	-	-	-	-	-	-	-	-
	2	-	-	-	-	-	-	-	-
	3	265	0.9	1.4	0.3	42	33	44	35
	4	340	1.1	1.6	0.4	48	39	50	41
	5	490	1.3	1.9	0.6	58	50	59	50
2	1	-	-	-	-	-	-	-	-
	2	-	-	-	-	-	-	-	-
	3	275	1.1	1.9	0.8	42	33	43	34
	4	350	1.3	2.1	1.0	46	37	49	40
	5	515	1.5	2.6	1.4	58	49	59	50
3	1	-	-	-	-	-	-	-	-
	2	-	-	-	-	-	-	-	-
	3	430	1.7	2.8	2.0	43	34	44	35
	4	615	2.1	3.4	2.8	52	44	53	44
	5	800	2.5	3.8	3.4	59	51	59	50
4	1	-	-	-	-	-	-	-	-
	2	-	-	-	-	-	-	-	-
	3	460	1.9	3.3	3.1	41	32	43	34
	4	670	2.3	4.0	4.5	51	42	52	43
	5	910	2.6	4.7	5.9	58	50	59	51
5	1	-	-	-	-	-	-	-	-
	2	-	-	-	-	-	-	-	-
	3	490	2.1	3.8	4.5	42	34	42	34
	4	700	2.5	4.6	6.4	51	42	52	43
	5	945	2.9	5.3	8.4	59	51	60	51
6	1	-	-	-	-	-	-	-	-
	2	-	-	-	-	-	-	-	-
	3	715	2.7	5.0	8.5	46	38	49	40
	4	930	3.2	5.8	11.1	55	47	56	47
	5	1200	3.7	6.5	13.8	62	54	63	54
7	1	-	-	-	-	-	-	-	-
	2	-	-	-	-	-	-	-	-
	3	735	3.0	5.5	11.2	46	38	48	39
	4	970	3.7	6.3	14.5	54	45	55	46
	5	1310	4.4	7.3	18.9	62	53	63	55
8	1	-	-	-	-	-	-	-	-
	2	-	-	-	-	-	-	-	-
	3	880	3.4	6.4	16.4	46	37	47	38
	4	1250	4.1	7.7	22.7	55	46	55	47
	5	1625	4.7	-	-	61	53	62	53

Motor thermal contact		
5-speed motor	TC integr.	<b>0</b>
	TC led out	<b>1</b>
EC motor		<b>E</b>

Metal sheet electric control box with terminal block or for integ. Controls



Speed combination

3-4-5	<b>M</b>
Min..Max (EC motor)	<b>S</b>

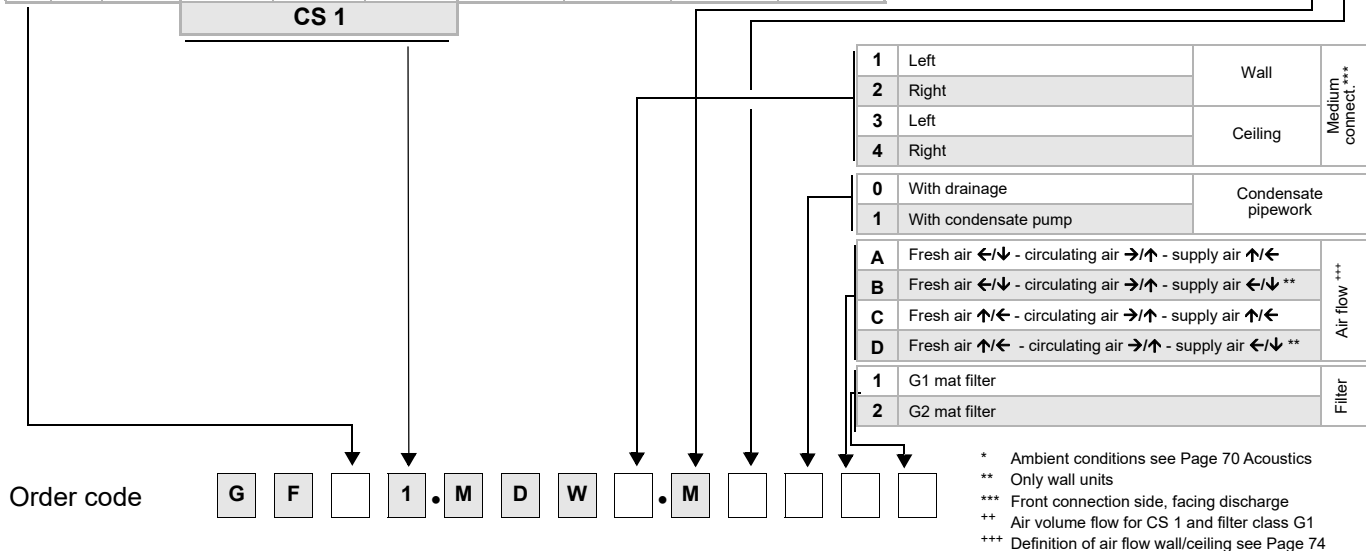

\* Ambient conditions see Page 70 Acoustics  
 \*\* Only wall units  
 \*\*\* Front connection side, facing discharge  
 \*\*\* Air volume flow for CS 1 and filter class G1  
 \*\*\* Definition of air flow wall/ceiling see Page 74



**FläktGroup MATRIX 2000**

not applicable

**FläktGroup MATRIX 4000**

**System features MATRIX 4000:**

- Temperature assignment.: 7...40 °C (default 10..30 °C)
- Speed (stage) assignment
- Adjustable regulating range
- Change-over between normal/economy mode on control panel
- Input for change-over between normal/economy mode or unit OFF with frost protection
- Room temperature measurement using control panel
- External room temperature sensor can be connected
- Valve control (3-point)
- Temperature control via fan and/or valve
- Room frost protection
- Status messages using LED
- Status and alarm signal via volt free change-over contacts
- Unit individual and group control
- Isolation of individual units in case of fault
- Motor temperature monitoring (with speed stage motors TC required)
- Network-enabled
- Summer / winter compensation
- Noiseless valve control
- Heat request via volt-free contact (related to water circuit)
- Stand alone unit control
- Inputs for operating mode:
  - Normal mode
  - Economy mode
  - Autonomous mode
  - Unit OFF
- Mixing-air damper control open/close with frost protection

**MATRIX OP30C**

Control panel for MATRIX 4000

- Pure white casing, protection type IP20
- Setpoint temperature setting
- Speed-stage selection switch 0-A(Auto)-1-2-3-4-5 (depends on motor type, with EC motor up to 5 stages)
- LEDs for operation/fault/ext.control
- Integrated room temperature sensor

**MATRIX OP31C**

As for control panel OP30C, but also with:

- Normal/economy mode buttons

**MATRIX OP44C**

As for control panel OP31C, but also with button for:

- Changeover between recirculating-air/ mixed-air operation
- Change-over heating/cooling/automatic mode

**MATRIX OP50C**

Control panel for MATRIX 4000

- Pure white casing, protection type IP20
- Menu-guided controls using rotation navigator
- LCD display with plain-text display
- Status messages using pictograms
- Integrated room temperature sensor
- Continuous speed assignment (only in connection with EC motor)

**MATRIX OP51C**

As for control panel OP50C, but also with:

- Integrated weekly clock timer with holiday and special days programme

**MATRIX.IR**

Infrared remote control for MATRIX 4000

- Black casing, RAL 9004
- LCD display approx. 45x30 mm
- Function as in OP44C (without status, alarm and external control signals, no integrated room temperature sensor)
- Maximum range 20 m
- Speed-stage selection switch 0-A(Auto)-1-2-3-4-5 (depends on motor type, with EC motor up to 5 stages)

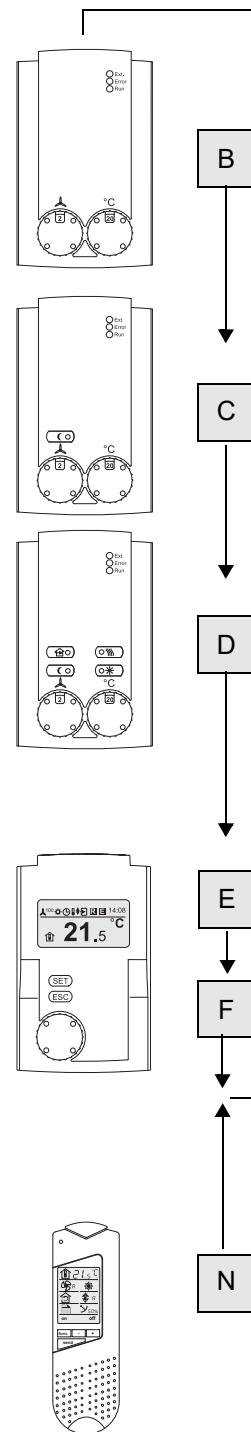

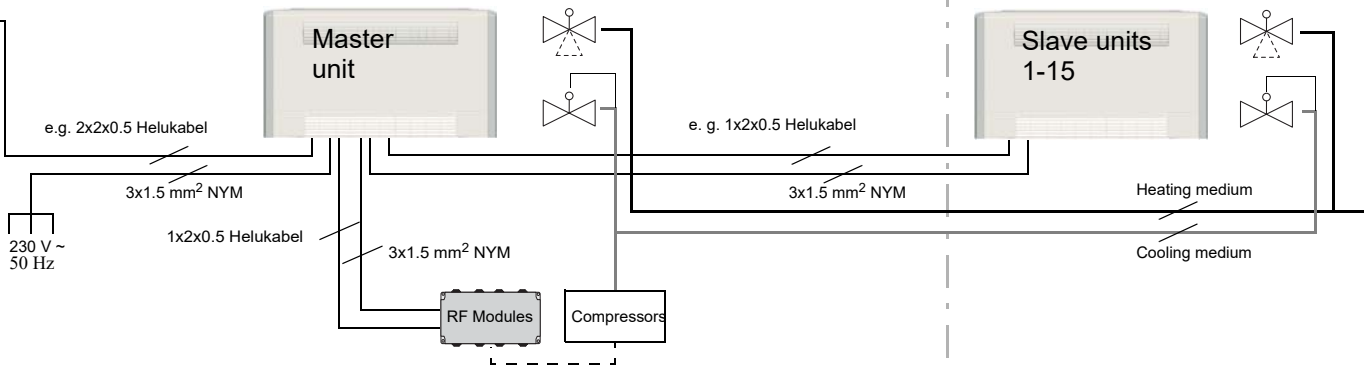

Speed (EC motor)	Speed stages (AC motor)	Stand alone unit control with operating and Fault signal	Input unit OFF with room frost protection	Input economy contact	Noiseless valve control	Contact heat and cool request	Connection external sensor	
Continuous	up to 3 speed	•	•				•	1
		•	•	•		•	•	2
		•	•	•	•	•	•	3

Without return air sensor *	3
With return air sensor *	8
Control panel	
Enclosed control panel	A
Integrated control panel	B

**Order code**

D 4 . 5 [ ] [ ] . [ ] [ ]

Master unit

D 4 . 5 [ ] [ ] . Z D

Slave unit

\* Alternatively room temperature sensor (see Page 99)

Mixed-Air Unit Heating or Cooling  
2-pipe chilled or warm water

CWP 6/12 °C    PWW 70/50 °C  
t<sub>L1</sub> = +27 °C    t<sub>L1</sub> = +10 °C  
φ<sub>1</sub> = 46 % r.h.

Flex-Geko

Sizes 1 to 8

Model size	Speeds	Air volume m <sup>3</sup> /h	Capacity stage 1				Capacity stage 2				Capacity stage 3				AC motor		EC motor	
			•Cooling capacity	Pressure drop	•Heating capacity	Pressure drop	•Cooling capacity	Pressure drop	•Heating capacity	Pressure drop	•Cooling capacity	Pressure drop	•Heating capacity	Pressure drop	Sound power	Sound pressure *	Sound power	Sound pressure *
			Q <sub>K</sub> kW	Δp <sub>K</sub> kPa	Q <sub>H</sub> kW	Δp <sub>H</sub> kPa	Q <sub>K</sub> kW	Δp <sub>K</sub> kPa	Q <sub>H</sub> kW	Δp <sub>H</sub> kPa	Q <sub>K</sub> kW	Δp <sub>K</sub> kPa	Q <sub>H</sub> kW	Δp <sub>H</sub> kPa	dB(A)	dB(A)	dB(A)	dB(A)
1	1	145	0.9	5.6	2.1	2.3	1.0	1.9	2.4	0.9	1.1	2.1	2.5	0.9	30	21	30	21
	2	210	1.2	8.7	2.7	3.7	1.4	3.3	3.3	1.5	1.6	3.9	3.5	1.7	36	28	38	30
	3	265	1.4	11.3	3.2	5.0	1.6	4.5	3.9	2.1	1.9	5.4	4.2	2.3	42	33	44	35
	4	340	1.6	14.5	3.8	6.8	1.9	6.1	4.6	2.9	2.2	7.7	5.1	3.4	48	39	50	41
	5	495	1.9	20.5	4.8	10.3	2.4	9.1	6.0	4.7	2.8	11.9	6.6	5.4	58	50	59	50
2	1	150	1.1	10.1	2.4	3.8	1.2	3.4	2.6	1.3	1.3	1.1	2.7	0.4	28	< 20	28	< 20
	2	220	1.5	16.9	3.2	6.5	1.7	6.0	3.7	2.3	1.6	1.7	3.8	0.7	35	26	37	28
	3	275	1.7	21.7	3.8	8.6	2.0	8.1	4.4	3.3	2.0	2.5	4.7	1.1	42	33	42	34
	4	350	2	28.2	4.4	11.6	2.4	11.1	5.4	4.7	2.5	3.6	5.6	1.6	46	37	48	40
	5	520	-	-	5.8	18.8	3.1	18.0	7.0	7.8	3.3	6.3	7.6	2.7	58	49	59	50
3	1	255	1.6	4.8	3.7	2.1	1.9	3.1	4.2	1.2	2.1	3.1	4.4	1.2	30	21	31	22
	2	320	1.9	6.4	4.4	2.8	2.3	4.3	5.2	1.8	2.5	4.4	5.4	1.7	35	27	37	28
	3	435	2.3	9.3	5.4	4.2	2.9	6.5	6.6	2.9	3.2	6.9	7.1	2.8	43	34	44	35
	4	615	2.8	13.4	6.9	6.5	3.7	10.2	8.5	4.6	4.1	11.0	9.3	4.6	52	44	53	44
	5	805	3.3	17.4	8.2	8.9	4.3	13.9	10.2	6.4	5.0	15.8	11.3	6.6	59	51	59	50
4	1	270	1.9	7.1	4.1	2.9	2.2	4.7	4.8	1.8	2.3	2.4	4.8	0.9	29	20	30	22
	2	335	2.2	9.6	4.9	3.9	2.6	6.4	5.7	2.5	2.7	3.3	5.8	1.2	35	26	35	27
	3	460	2.7	13.9	6.1	5.9	3.3	9.8	7.3	3.9	3.6	5.5	7.7	2.1	41	32	43	34
	4	675	3.4	21.1	7.9	9.6	4.4	16.1	9.8	6.7	4.7	9.2	10.4	3.7	51	42	52	43
	5	915	4.0	29.0	9.7	13.8	5.2	22.4	12.1	9.9	5.9	13.6	13.2	5.7	58	50	59	50
5	1	280	2.1	9.6	4.5	3.7	2.4	6.3	5.0	2.2	2.5	3.2	5.0	1.1	28	< 20	29	20
	2	345	2.4	12.6	5.2	5.0	2.9	8.6	6.0	3.0	3.0	4.5	6.1	1.5	34	25	34	25
	3	495	3.1	20.0	6.8	8.1	3.8	13.8	8.1	5.3	4.0	7.6	8.4	2.8	42	34	42	34
	4	700	3.8	29.6	8.7	12.5	4.8	21.6	10.6	8.7	5.3	12.5	11.4	4.8	51	42	51	43
	5	950	4.5	40.4	10.7	18.4	5.9	31.2	13.2	13.0	6.5	18.2	14.3	7.3	59	51	60	51
6	1	410	2.5	2.5	6.0	1.2	2.8	1.5	6.8	0.7	3.0	0.8	7.0	0.4	33	24	35	26
	2	525	3.0	3.5	7.2	1.7	3.6	2.3	8.4	1.1	3.5	1.1	8.7	0.5	39	31	41	32
	3	715	3.7	5.1	8.9	2.5	4.6	3.7	10.9	1.7	4.8	1.9	11.4	0.9	46	38	49	40
	4	935	4.3	6.9	10.7	3.5	5.5	5.2	13.1	2.4	6.1	3.0	14.2	1.4	55	47	56	47
	5	1210	5.0	9.0	12.6	4.8	6.5	7.0	15.7	3.4	7.2	4.2	17.0	1.9	62	54	63	54
7	1	435	2.8	3.4	6.5	1.5	3.3	2.2	7.4	0.9	3.3	1.1	7.6	0.5	33	24	34	26
	2	545	3.3	4.7	7.7	2.1	4.0	3.1	9.1	1.3	4.0	1.6	9.3	0.7	38	30	40	31
	3	735	4.1	6.8	9.6	3.1	5.0	4.7	11.5	2.0	5.3	2.5	12.1	1.1	46	38	47	39
	4	975	4.8	9.2	11.6	4.4	6.1	6.9	14.2	3.0	6.6	3.8	15.1	1.7	54	45	55	46
	5	1320	5.7	12.5	14.1	6.3	7.4	9.8	17.5	4.4	8.3	5.9	19.1	2.5	62	53	63	54
8	1	530	3.5	5.5	7.9	2.3	4.1	3.5	9.0	1.4	4.1	1.8	9.2	0.7	34	25	35	26
	2	630	3.9	6.8	8.9	2.9	4.7	4.5	10.4	1.8	4.9	2.4	10.6	0.9	38	29	39	30
	3	885	4.9	10.2	11.3	4.5	6.0	7.2	13.7	3.0	6.4	3.9	14.3	1.6	46	37	47	38
	4	1260	6.0	14.8	14.4	7.0	7.7	11.3	17.7	4.9	8.3	6.3	18.9	2.7	55	46	55	47
	5	1640	6.9	19.1	17.0	9.5	9.1	15.1	21.2	6.8	10.2	9.1	23.0	3.8	61	53	62	53

Motor design		
AC motor	TC integr.	0
	TC led out	1
EC motor		E

Plastic terminal box (with MATRIX metal sheet electrical control box)



Speed combination

1-2-3 <sup>+</sup>	A
2-3-4 <sup>+</sup>	B
3-4-5 <sup>+</sup>	C
1-3-5 <sup>+</sup>	E
1-2-3-4-5 <sup>+</sup>	H
Min..Max (EC motor)	F

Metal sheet electric control box with terminal strip or for integ. Controls



Speed combination

1-2-3 <sup>+</sup>	K
2-3-4 <sup>+</sup>	L
3-4-5 <sup>+</sup>	M
1-3-5 <sup>+</sup>	O
1-2-3-4-5 <sup>+</sup>	R
Min..Max (EC motor)	S

Data for capacity stage 4 (CS 4) are available on request (see Page 11).

1	Left	Wall	Medium connect.***
2	Right		
3	Left	Ceiling	
4	Right		
0	With drainage	Condensate pipework	
1	With condensate pump		
A	Fresh air ←↕-circulating air ↗↔ - supply air ↗↔	Air flow ***	
B	Fresh air ←↕-circulating air ↗↔** supply air ↗↔**		
C	Fresh air ↗↔-circulating air ↗↔ - supply air ↗↔		
D	Fresh air ↗↔-circulating air ↗↔** supply air ↗↔**		
1	G1 mat filter	Filter	
2	G2 mat filter		
3	G3 mat filter		

\* Ambient conditions see Page 70 Acoustics  
\*\* Only wall units  
\*\*\* Front connection side, facing discharge  
+ only AC motor  
\*\* Air volume flow for CS 1 and filter class G1  
\*\*\* Definition of air flow wall/ceiling see Page 74

Order code

G F . M W C . . . . .



### Accessories

Arrangement/installation	Variant/unit casing	Suitable for air flow designation	Discharge grille	Code
	Vertical wall/horizontal ceiling; with unit foot cover and intake front grille	A, C	Plastic adjustable	C 072
			Aluminium rigid	C 073
	Vertical wall; on front side with unit foot cover and intake front grille	B, D	Plastic adjustable	C 082

Variant	Type	Code
	insulated	A 022
	insulated	A 042
	insulated	A 062
		A 112
		A 212
	Left	A 412
	Right	A 422
		A 231
		A 311
		A 331
		A 371
	insulated	A 713
	G1	A 813
	G2	A 823
	G3	A 833

Sizes 1 to 8  
\* 0, if irrespective of size

**Order code**    Z   G   F   •   [ ]   [ ]   [ ]   [ ]   [ ]

**\*\* NOTE!**  
Geko-Drive only together with unit casing!

### Valves

MATRIX 2000	MATRIX 3000/4000	Terminal box	Drive	Operating voltage/circuit	
	•	•	3-point open/stop/close	230 V AC	R
				24 V AC <sup>1)</sup>	N
				230 V AC + 2 contacts	C
		•	Continuous	0/2 ... 10 V = 24 V AC <sup>1)</sup>	S

Connection/shut-off	
Inlet/outlet flow with outside thread	0
Inlet/outlet with solder fitting	1
Inlet/outlet + ball trap with external thread	2
Inlet/outlet + ball trap with solder fitting	3
Inlet + ball trap/outlet + shut-off valve with external thread	4
Inlet + ball trap/outlet + shut-off valve with solder fitting	5

Medium connection	
Left	L
Right	R

k <sub>vs</sub> values Cooling/Heating		
0.25	≡	03
0.40	≡	04
0.63	≡	06
1.00	≡	10
1.60	≡	16
2.50	≡	25
4.00	≡	40

Cool / heat circuit

3

<sup>1)</sup> 24 V-transformer to be provided by others

**Order code**    V   G   F   •   [ ]   3   [ ]   [ ]   •   [ ]   [ ]

Cooling/heating circuit

### FläktGroup MATRIX 2000

not applicable

### FläktGroup MATRIX 4000

#### System features MATRIX 4000:

- Temperature assignment.: 7...40 °C (default 10..30 °C)
- Speed (stage) assignment
- Adjustable regulating range
- Change-over between normal/economy mode on control panel
- Input for change-over between normal/economy mode or unit OFF with frost protection
- Room temperature measurement using control panel
- External room temperature sensor can be connected
- Valve control (3-point)
- Temperature control via fan and/or valve
- Room frost protection
- Status messages using LED
- Status and alarm signal via volt free change-over contacts
- Unit individual and group control
- Isolation of individual units in case of fault
- Motor temperature monitoring (with speed stage motors TC required)
- Network-enabled
- Summer / winter compensation
- Noiseless valve control
- Cool and/or heat request via volt-free contacts (related to water circuit)
- Stand alone unit control
- Inputs for operating mode:
  - Normal mode
  - Economy mode
  - Autonomous mode
  - Unit OFF
- Mixing-air damper control open/close with frost protection

#### MATRIX OP30C

Control panel for MATRIX 4000

- Pure white casing, protection type IP20
- Setpoint temperature setting
- Speed-stage selection switch 0-A(Auto)-1-2-3-4-5 (depends on motor type, with EC motor up to 5 stages)
- LEDs for operation/fault/ext.control
- Integrated room temperature sensor

#### MATRIX OP31C

As for control panel OP30C, but also with:

- Normal/economy mode buttons

#### MATRIX OP44C

As for control panel OP31C, but also with button for:

- Changeover between recirculating-air/mixed-air operation
- Change-over heating/cooling/automatic mode

#### MATRIX OP50C

Control panel for MATRIX 4000

- Pure white casing, protection type IP20
- Menu-guided controls using rotation navigator
- LCD display with plain-text display
- Status messages using pictograms
- Integrated room temperature sensor
- Continuous speed assignment (only in connection with EC motor)

#### MATRIX OP51C

As for control panel OP50C, but also with:

- Integrated weekly clock timer with holiday and special days programme

#### MATRIX.IR

Infrared remote control for control system MATRIX 4000

- Black casing, RAL 9004
- LCD display approx. 45x30 mm
- Function as in OP44C (without status, alarm and external control signals, no integrated room temperature sensor)
- Maximum range 20 m
- Speed-stage selection switch 0-A(Auto)-1-2-3-4-5 (depends on motor type, with EC motor up to 5 stages)

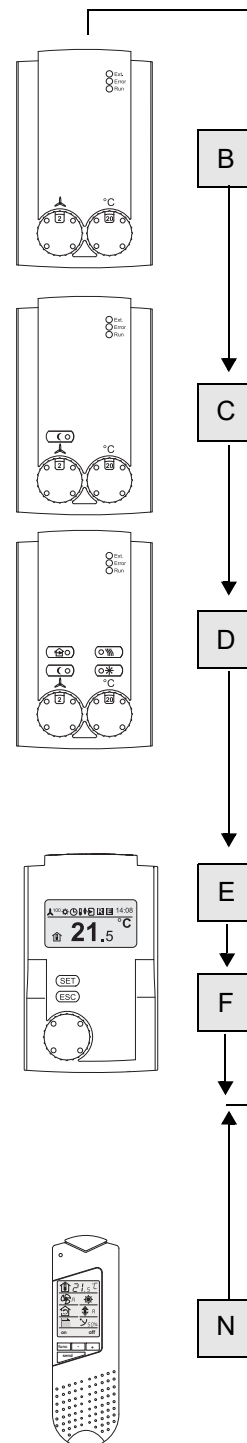

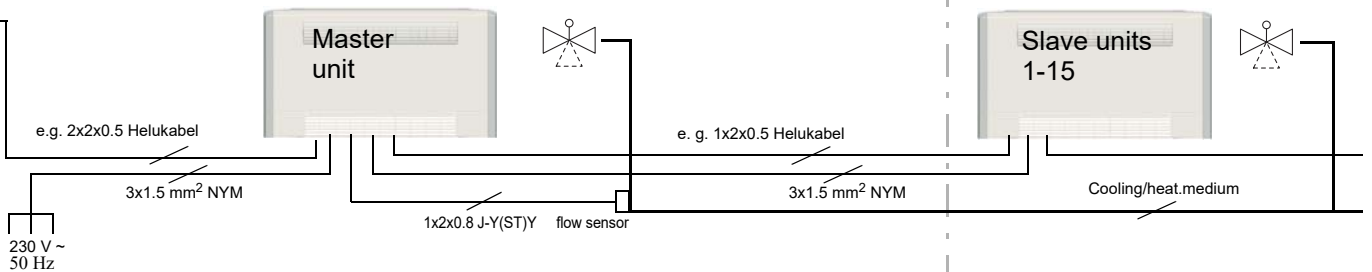

Speed (EC motor)	Speed stages (AC motor)	Stand alone unit control with operating and Fault signal	Input unit OFF with room frost protection	Input economy contact	Supply temperature limitation	Noiseless valve control	Contact heat and cool request	Geko-Drive	Connection external sensor	
Continuous	up to 3 speed	•	•			•			•	1
		•		•		•			•	2
		•	•		•	•			•	3
	up to 5 speed	•	•	•		•		•	•	4
		•	•	•	•	•	•	•	•	5
		•	•	•	•	•	•	•	•	6

Without return air sensor *	0
With return air sensor *	5

Control panel	
Enclosed control panel	A
Integrated control panel	B

**Order code**

D 4 . 4 [ ] [ ] . [ ] [ ]

Master unit

- 1
- 2
- 3
- 4
- 5
- 6
- 6

D 4 . 4 [ ] [ ] . Z D

Slave unit

\* Alternatively room temperature sensor (see Page 99)

Sizes 1 to 8

Model size	Speeds	Air volume m <sup>3</sup> /h	Capacity stage 1				Capacity stage 2				Capacity stage 3				AC-motor		EC motor	
			Q <sub>K</sub> •Cooling capacity	Pressure drop	Q <sub>H</sub> •Heating capacity	Pressure drop	Q <sub>K</sub> •Cooling capacity	Pressure drop	Q <sub>H</sub> •Heating capacity	Pressure drop	Q <sub>K</sub> •Cooling capacity	Pressure drop	Q <sub>H</sub> •Heating capacity	Pressure drop	Sound power	Sound pressure *	Sound power	Sound pressure *
			Δp <sub>K</sub> kPa	Δp <sub>H</sub> kPa	Δp <sub>K</sub> kPa	Δp <sub>H</sub> kPa	Δp <sub>K</sub> kPa	Δp <sub>H</sub> kPa	Δp <sub>K</sub> kPa	Δp <sub>H</sub> kPa	Δp <sub>K</sub> kPa	Δp <sub>H</sub> kPa	Δp <sub>K</sub> kPa	Δp <sub>H</sub> kPa	dB(A)	dB(A)	dB(A)	dB(A)
1	1	145	-	-	2.1	2.3	-	-	2.4	0.9	-	-	2.5	0.9	30	21	30	21
	2	210	-	-	2.7	3.7	-	-	3.3	1.5	-	-	3.5	1.7	36	28	38	30
	3	265	-	-	3.2	5.0	-	-	3.9	2.1	-	-	4.2	2.3	42	33	44	35
	4	340	-	-	3.8	6.8	-	-	4.6	2.9	-	-	5.1	3.4	48	39	50	41
	5	495	-	-	4.8	10.3	-	-	6.0	4.7	-	-	6.6	5.4	58	50	59	50
2	1	150	-	-	2.4	3.8	-	-	2.6	1.3	-	-	2.7	0.4	28	< 20	28	< 20
	2	220	-	-	3.2	6.5	-	-	3.7	2.3	-	-	3.8	0.7	35	26	37	28
	3	275	-	-	3.8	8.6	-	-	4.4	3.3	-	-	4.7	1.1	42	33	42	34
	4	350	-	-	4.4	11.6	-	-	5.4	4.7	-	-	5.6	1.6	46	37	48	40
	5	520	-	-	5.8	18.8	-	-	7.0	7.8	-	-	7.6	2.7	58	49	59	50
3	1	255	-	-	3.7	2.1	-	-	4.2	1.2	-	-	4.4	1.2	30	21	31	22
	2	320	-	-	4.4	2.8	-	-	5.2	1.8	-	-	5.4	1.7	35	27	37	28
	3	435	-	-	5.4	4.2	-	-	6.6	2.9	-	-	7.1	2.8	43	34	44	35
	4	615	-	-	6.9	6.5	-	-	8.5	4.6	-	-	9.3	4.6	52	44	53	44
	5	805	-	-	8.2	8.9	-	-	10.2	6.4	-	-	11.3	6.6	59	51	59	50
4	1	270	-	-	4.1	2.9	-	-	4.8	1.8	-	-	4.8	0.9	29	20	30	22
	2	335	-	-	4.9	3.9	-	-	5.7	2.5	-	-	5.8	1.2	35	26	35	27
	3	460	-	-	6.1	5.9	-	-	7.3	3.9	-	-	7.7	2.1	41	32	43	34
	4	675	-	-	7.9	9.6	-	-	9.8	6.7	-	-	10.4	3.7	51	42	52	43
	5	915	-	-	9.7	13.8	-	-	12.1	9.9	-	-	13.2	5.7	58	50	59	50
5	1	280	-	-	4.5	3.7	-	-	5.0	2.2	-	-	5.0	1.1	28	< 20	29	20
	2	345	-	-	5.2	5.0	-	-	6.0	3.0	-	-	6.1	1.5	34	25	34	25
	3	495	-	-	6.8	8.1	-	-	8.1	5.3	-	-	8.4	2.8	42	34	42	34
	4	700	-	-	8.7	12.5	-	-	10.6	8.7	-	-	11.4	4.8	51	42	51	43
	5	950	-	-	10.7	18.4	-	-	13.2	13.0	-	-	14.3	7.3	59	51	60	51
6	1	410	-	-	6.0	1.2	-	-	6.8	0.7	-	-	7.0	0.4	33	24	35	26
	2	525	-	-	7.2	1.7	-	-	8.4	1.1	-	-	8.7	0.5	39	31	41	32
	3	715	-	-	8.9	2.5	-	-	10.9	1.7	-	-	11.4	0.9	46	38	49	40
	4	935	-	-	10.7	3.5	-	-	13.1	2.4	-	-	14.2	1.4	55	47	56	47
	5	1210	-	-	12.6	4.8	-	-	15.7	3.4	-	-	17.0	1.9	62	54	63	54
7	1	435	-	-	6.5	1.5	-	-	7.4	0.9	-	-	7.6	0.5	33	24	34	26
	2	545	-	-	7.7	2.1	-	-	9.1	1.3	-	-	9.3	0.7	38	30	40	31
	3	735	-	-	9.6	3.1	-	-	11.5	2.0	-	-	12.1	1.1	46	38	47	39
	4	975	-	-	11.6	4.4	-	-	14.2	3.0	-	-	15.1	1.7	54	45	55	46
	5	1320	-	-	14.1	6.3	-	-	17.5	4.4	-	-	19.1	2.5	62	53	63	54
8	1	530	-	-	7.9	2.3	-	-	9.0	1.4	-	-	9.2	0.7	34	25	35	26
	2	630	-	-	8.9	2.9	-	-	10.4	1.8	-	-	10.6	0.9	38	29	39	30
	3	885	-	-	11.3	4.5	-	-	13.7	3.0	-	-	14.3	1.6	46	37	47	38
	4	1260	-	-	14.4	7.0	-	-	17.7	4.9	-	-	18.9	2.7	55	46	55	47
	5	1640	-	-	17.0	9.5	-	-	21.2	6.8	-	-	23.0	3.8	61	53	62	53

Motor design		
AC motor	TC integr.	0
	TC led out	1
EC motor		E

Plastic terminal box (with MATRIX metal sheet electrical control box)



Speed combination

1-2-3 <sup>+</sup>	A
2-3-4 <sup>+</sup>	B
3-4-5 <sup>+</sup>	C
1-3-5 <sup>+</sup>	E
1-2-3-4-5 <sup>+</sup>	H
Min..Max (EC motor)	F

Metal sheet electric control box with terminal strip or for integ. Controls



Speed combination

1-2-3 <sup>+</sup>	K
2-3-4 <sup>+</sup>	L
3-4-5 <sup>+</sup>	M
1-3-5 <sup>+</sup>	O
1-2-3-4-5 <sup>+</sup>	R
Min..Max (EC motor)	S

Data for capacity stage 4 (CS 4) are available on request (see Page 11).

**Order code**

G F [ ] [ ] . M 0 W [ ] . [ ] [ ] 0 [ ] [ ]

1	Left	Wall	Medium connect.***
2	Right		
3	Left	Ceiling	
4	Right		

A	Fresh air ←/↓ - circulating air →/↑ - supply air ↑/←	Air flow ***
B	Fresh air ←/↓ - circulating air →/↑ - supply air ←/↓	
C	Fresh air ↑/← - circulating air →/↑ - supply air ↑/←	
D	Fresh air ↑/← - circulating air →/↑ - supply air ←/↓	

1	G1 mat filter	Filter
2	G2 mat filter	
3	G3 mat filter	

\* Ambient conditions see Page 70 Acoustics  
 \*\* Only wall units  
 \*\*\* Front connection side, facing discharge  
 + only AC motor  
 ++ Air volume flow for CS 1 and filter class G1  
 \*\*\* Definition of air flow wall/ceiling see Page 74

Accessories					Variant		Type	Code
	Vertical wall/horizontal ceiling; with unit foot cover and intake front grille	A, C	Discharge grille	Plastic adjustable	C	Discharge plenum primary air connection DN100	not insulated	A 012
				Aluminium rigid	C		insulated	022
	Vertical wall/horizontal ceiling; with unit foot cover and intake front grille	B, D	Discharge grille	Plastic adjustable	C	Discharge plenum with round fitting DN200	not insulated	A 032
							insulated	042
	Discharge bend						not insulated	A 052
							insulated	062
	Flexible canvas discharge connector							A 112
	Discharge telescopic connection						not insulated	A 152
	Discharge sound attenuator connector							A 212
	Geko-Drive – motorized regulated discharge profile **						left	A 412
							right	422
	Intake fitting for sound attenuator for mixed-air units							A 231
	Frame for in-wall installation for outside air intake connection							A 311
	External weather grille, RAL 9006 paint							A 331
	Installation frame for weather protection grille							A 371
	Seal cap for round fitting, DN 200 *						insulated	A 713
	Spare filter (5 pieces)						G1	813
							G2	A 823
							G3	833

<b>Sizes 1 to 8</b> * 0, if irrespective of size	<b>Order code</b>	Z	G	F	.					
---	-------------------	---	---	---	---	--	--	--	--	--

Valves				
MATRIX 2000	MATRIX 3000/4000	Terminal box	Drive	Operating voltage/circuit
			3-point open/stop/close	230 V AC
				24 V AC <sup>1)</sup>
				230 V AC + 2 contacts
			Continuous	0/2 ... 10 V = 24 V AC <sup>1)</sup>
				R
				N
				C
				S

Connection/shut-off	
Inlet/outlet flow with outside thread	0
Inlet/outlet with solder fitting	1
Inlet/outlet + ball trap with external thread	2
Inlet/outlet + ball trap with solder fitting	3
Inlet + ball trap/outlet + shut-off valve with external thread	4
Inlet + ball trap/outlet + shut-off valve with solder fitting	5

Medium connection	
Left	L
right	R

kvs values Heating	
0.25	≡ 03
0.40	≡ 04
0.63	≡ 06
1.00	≡ 10
1.60	≡ 16
2.50	≡ 25
4.00	≡ 40

<b>Order code</b>	V	G	F	.		3			.		
-------------------	---	---	---	---	--	---	--	--	---	--	--

Heating circuit

<sup>1)</sup> 24 V-transformer to be provided by others

**FläktGroup MATRIX 2000**

not applicable

**FläktGroup MATRIX 4000**

**System features MATRIX 4000:**

- Temperature assignment.: 7...40 °C (default 10..30 °C)
- Speed (stage) assignment
- Adjustable regulating range
- Change-over between normal/economy mode on control panel
- Input for change-over between normal/economy mode or unit OFF with frost protection
- Room temperature measurement using control panel
- External room temperature sensor can be connected
- Valve control (3-point)
- Temperature control via fan and/or valve
- Room frost protection
- Status messages using LED
- Status and alarm signal via volt free change-over contacts
- Unit individual and group control
- Isolation of individual units in case of fault
- Motor temperature monitoring (with speed stage motors TC required)
- Network-enabled
- Summer / winter compensation
- Noiseless valve control
- Heat request via volt-free contact (related to water circuit)
- Stand alone unit control
- Inputs for operating mode:
  - Normal mode
  - Economy mode
  - Autonomous mode
  - Unit OFF
- Mixing-air damper control open/close with frost protection

**MATRIX OP30C**

Control panel for MATRIX 4000

- Pure white casing, protection type IP20
- Setpoint temperature setting
- Speed-stage selection switch 0-A(Auto)-1-2-3-4-5 (depends on motor type, with EC motor up to 5 stages)
- LEDs for operation/fault/ext.control
- Integrated room temperature sensor

**MATRIX OP31C**

As for control panel OP30C, but also with:

- Normal/economy mode buttons

**MATRIX OP44C**

As for control panel OP31C, but also with button for:

- Changeover between recirculating-air/mixed-air operation
- Change-over heating/cooling/automatic mode

**MATRIX OP50C**

Control panel for MATRIX 4000

- Pure white casing, protection type IP20
- Menu-guided controls using rotation navigator
- LCD display with plain-text display
- Status messages using pictograms
- Integrated room temperature sensor
- Continuous speed assignment (only in connection with EC motor)

**MATRIX OP51C**

As for control panel OP50C, but also with:

- Integrated weekly clock timer with holiday and special days programme

**MATRIX.IR**

Infrared remote for control system MATRIX 4000

- Black casing, RAL 9004
- LCD display approx. 45x30 mm
- Function as in OP44C (without status, alarm and external control signals, no integrated room temperature sensor)
- Maximum range 20 m
- Speed-stage selection switch 0-A(Auto)-1-2-3-4-5 (depends on motor type, with EC motor up to 5 stages)

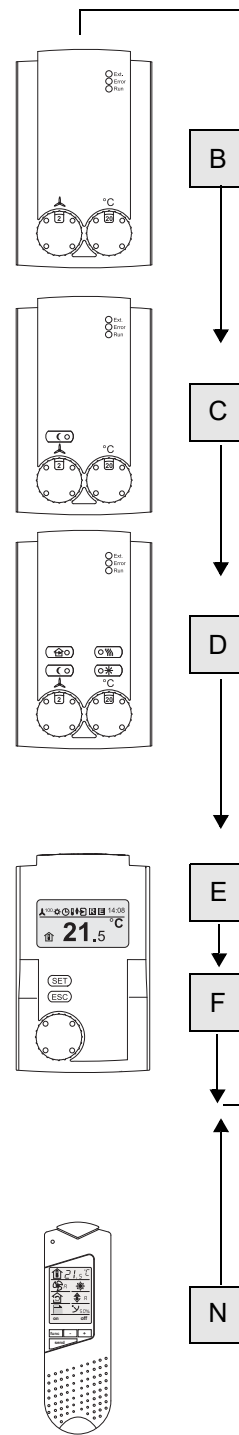

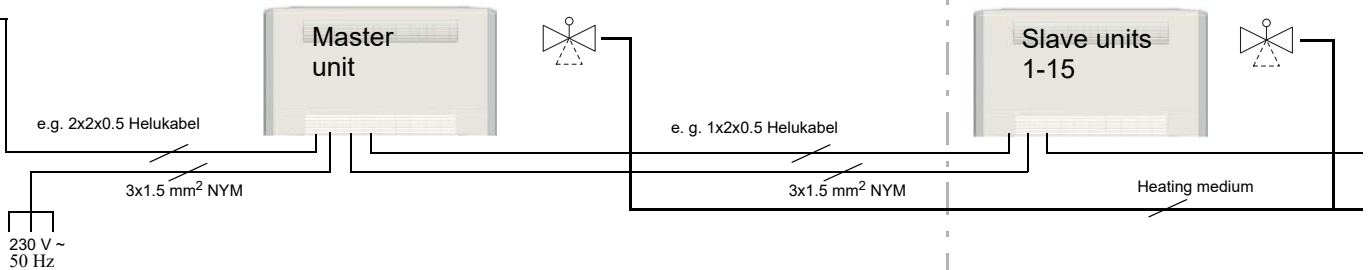

Speed EC motor	Speed stages AC motor	Stand alone unit control with operating and Fault signal	Input unit OFF with room frost protection	Input economy contact	Supply temperature limitation	Noiseless valve control	Contact heat and cool request	Connection external sensor	
Continuous	up to 3 speed	•	•			•		•	1
		•	•	•		•		•	2
		•	•	•	•	•		•	3
	up to 5 speed	•	•	•		•	•	•	4
		•	•	•	•	•	•	•	5
		•	•	•	•	•	•	•	6

without return air sensor *	0
with return air sensor *	5

Control panel	
Enclosed control panel	A
Integrated control panel	B

**Order code**

\* Alternatively room temperature sensor (see Page 99)

D 4 . 3 [ ] [ ] . [ ] [ ]

Master unit

D 4 . 3 [ ] [ ] . Z D

Slave unit

- 1
- 2
- 3
- 4
- 5
- 6

Model size	Speeds	Air volume m <sup>3</sup> /h	Capacity stage 1				AC-motor	
			Cooling capacity Q <sub>K</sub> kW	Pressure drop Δp <sub>K</sub> kPa	Full electric heating Q <sub>H</sub> kW	Pressure drop Δp <sub>H</sub> kPa	Sound power dB(A)	Sound pressure * dB(A)
1	1	-	-	-	-	-	-	-
	2	-	-	-	-	-	-	-
	3	265	-	-	2.07	-	42	33
	4	340	-	-	2.07	-	48	39
	5	495	-	-	4.14	-	58	50
2	1	-	-	-	-	-	-	-
	2	-	-	-	-	-	-	-
	3	275	-	-	2.52	-	42	33
	4	350	-	-	2.52	-	46	37
	5	520	-	-	5.04	-	58	49
3	1	-	-	-	-	-	-	-
	2	-	-	-	-	-	-	-
	3	435	-	-	3.69	-	43	34
	4	615	-	-	3.69	-	52	44
	5	805	-	-	7.38	-	59	51
4	1	-	-	-	-	-	-	-
	2	-	-	-	-	-	-	-
	3	460	-	-	4.20	-	41	32
	4	675	-	-	4.20	-	51	42
	5	915	-	-	8.40	-	58	50
5	1	-	-	-	-	-	-	-
	2	-	-	-	-	-	-	-
	3	475	-	-	4.89	-	42	34
	4	690	-	-	4.89	-	51	42
	5	950	-	-	9.78	-	59	51
6	1	-	-	-	-	-	-	-
	2	-	-	-	-	-	-	-
	3	715	-	-	4.98	-	46	38
	4	935	-	-	4.98	-	55	47
	5	1210	-	-	9.96	-	62	54
7	1	-	-	-	-	-	-	-
	2	-	-	-	-	-	-	-
	3	735	-	-	6.18	-	46	38
	4	975	-	-	6.18	-	54	45
	5	1320	-	-	12.36	-	62	53
8	1	-	-	-	-	-	-	-
	2	-	-	-	-	-	-	-
	3	885	-	-	6.18	-	46	37
	4	1260	-	-	6.18	-	55	46
	5	1640	-	-	12.36	-	61	53

Motor design		
AC motor	TC integr.	0
	TC led out	1

Metal-sheet electric control box with terminal block or for integrated controls



Speed combination

3-4-5	M
-------	---

CS 1

1	Right	Wall	Electric connection ***
3	Right	Ceiling	
A	Fresh air ←↻ - circulating air →↻ - supply air ↻←		Air flow +++
C	Fresh air ↻← - circulating air →↻ - supply air ↻←		
1	G1 mat filter		Filter
2	G2 mat filter		

Order code

G F  1 . M 0 E  . M  0 A

\* Ambient conditions see Page 70 Acoustics  
 \*\*\* Front connection side, facing discharge  
 ++ Air volume flow for CS 1 and filter class G1  
 \*\*\* Definition of air flow wall/ceiling see Page 74



**Accessories**

Arrangement/ installation	Variant/ unit casing	Suitable for air flow des- ignation	Discharge grille	Code	
	Vertical wall/ horizontal ceiling; with unit foot cover and intake front grille	A, C	Aluminium rigid	C	073

Variant	Type	Code	
Discharge plenum primary air connection DN100	not insulated	A	012
Discharge bend	not insulated	A	052
Discharge telescopic con- nection	not insulated	A	152
Frame for in-wall installation for outside air intake connection		A	311
External weather grille, RAL 9006 paint		A	331
Installation frame for weather protection grille		A	371
Spare filter (5 pieces)	G1	A	813
	G2		823

Sizes 1 to 8  
\* 0, if irrespective  
of size

**Order code**    Z   G   F   •

Full electric heating, model sizes 1 to 8

### FläktGroup MATRIX 2000

not applicable

### FläktGroup MATRIX 4000

#### System features MATRIX 4000:

- Temperature assignment.: 7...40 °C (default 10..30 °C)
- Assignment of speed stage
- Adjustable regulating range
- Change-over between normal/economy mode on control panel
- Input for change-over between normal/economy mode or unit OFF with frost protection
- Room temperature measurement using control panel
- External room temperature sensor can be connected
- Temperature control via fan
- Room frost protection
- Status messages using LED
- Status and alarm signal via volt free change-over contacts
- Unit individual and group control
- Isolation of individual units in case of fault
- Motor temperature monitoring (with speed stage motors TC required)
- Network-enabled
- Summer / winter compensation
- Stand alone unit control
- Inputs for operating mode:
  - Normal mode
  - Economy mode
  - Autonomous mode
  - Unit OFF
- Mixing-air damper control open/close with frost protection
- Regulation of multi-stage electrical heating with disconnection in case of over-temperature

#### MATRIX OP30C

Control panel for MATRIX 4000

- Pure white casing, protection type IP20
- Setpoint temperature setting
- Speed stage selection switch 0-A(Auto)-1-2-3
- LEDs for operation/fault/ext.control
- Integrated room temperature sensor

#### MATRIX OP31C

As for control panel OP30C, but also with:

- Normal/economy mode buttons

#### MATRIX OP44C

As for control panel OP31C, but also with button for:

- Changeover between recirculating-air/ mixed-air operation
- Change-over heating/cooling/automatic mode

#### MATRIX OP50C

Control panel for MATRIX 4000

- Pure white casing, protection type IP20
- Menu-guided controls using rotation navigator
- LCD display with plain-text display
- Status messages using pictograms
- Integrated room temperature sensor

#### MATRIX OP51C

As for control panel OP50C, but also with:

- Integrated weekly clock timer with holiday and special days programme

#### MATRIX.IR

Infrared remote control for control system MATRIX 4000

- Black casing, RAL 9004
- LCD display approx. 45x30 mm
- Function as in OP44C (without status, alarm and external control signals, no integrated room temperature sensor)
- Maximum range 20 m
- Speed stage selection switch 0-A(Auto)-1-2-3

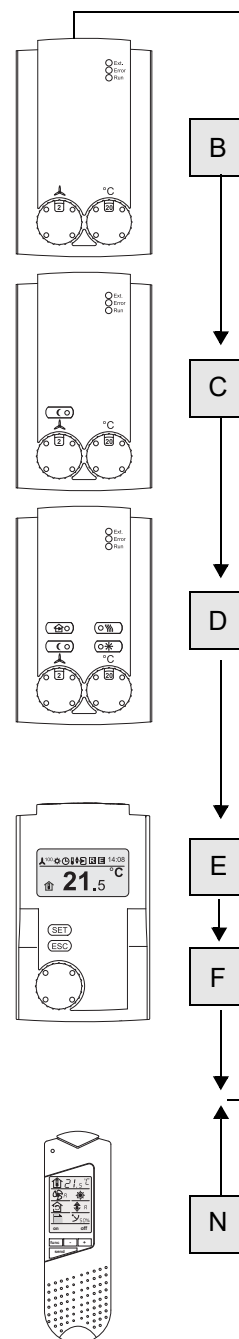

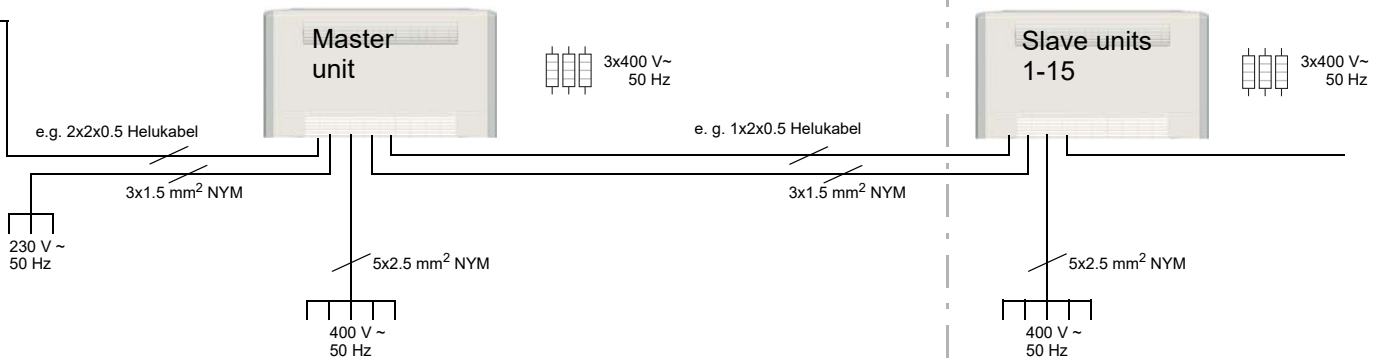

Speeds	Stand alone unit control with operating and Fault signal	Input unit OFF with room frost protection	Input economy contact	Contact heat request	Connection external sensor	
up to 3 speed	•	•			•	1
	•		•		•	2
	•	•	•	•	•	3

Without return air sensor *	2
With return air sensor *	7
Control panel	
Enclosed control panel	A
Integrated control panel	B

**Order code**

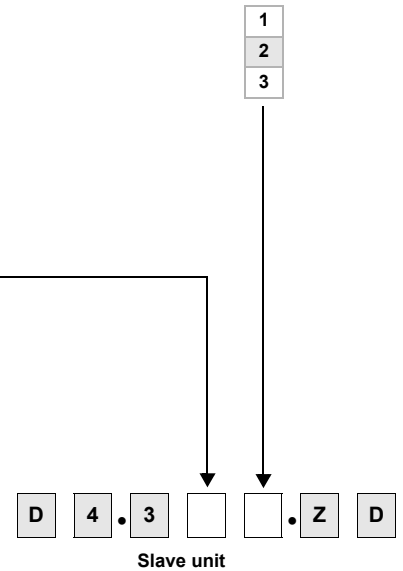
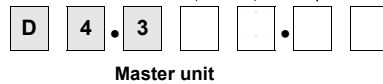

\* Alternatively room temperature sensor (see Page 99)

Cooling, 2-pipe system, CS 1

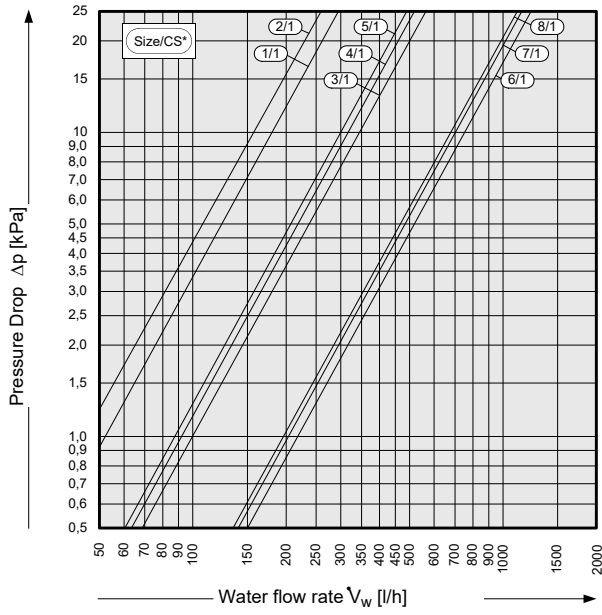

Cooling, 2-pipe system, CS 2 + CS 3

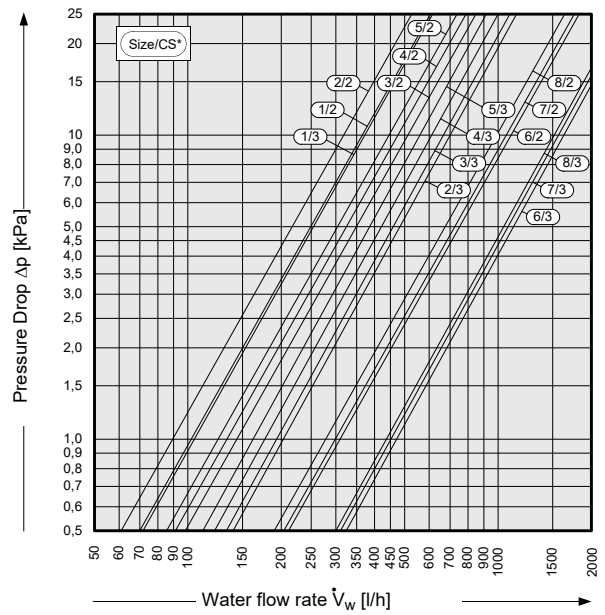

Heating, 2-pipe system, CS 1 + CS 2

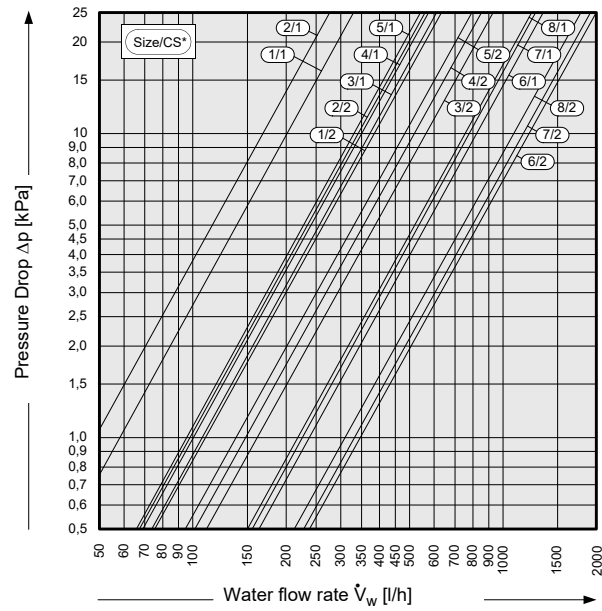

Heating, 2-pipe system, CS 3

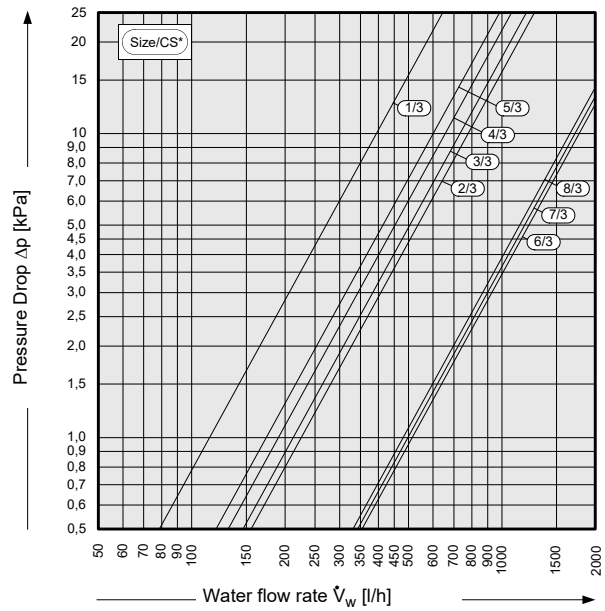

Cooling, 4-pipe system, CS 2 + CS 3

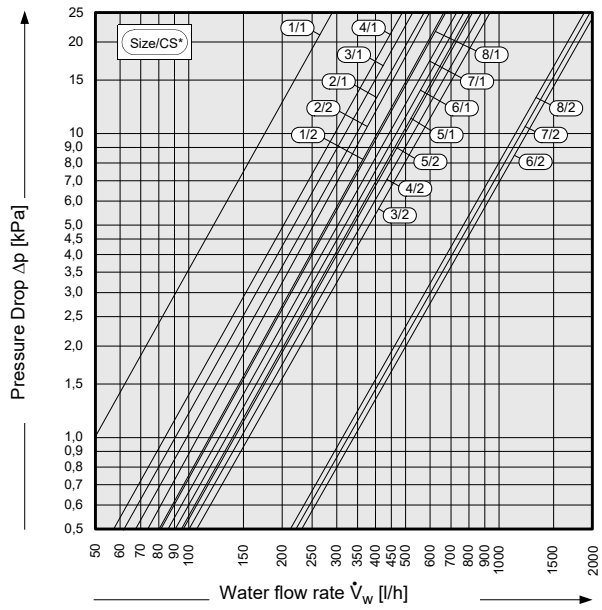

Heating, 4-pipe system, CS 1 + CS 2

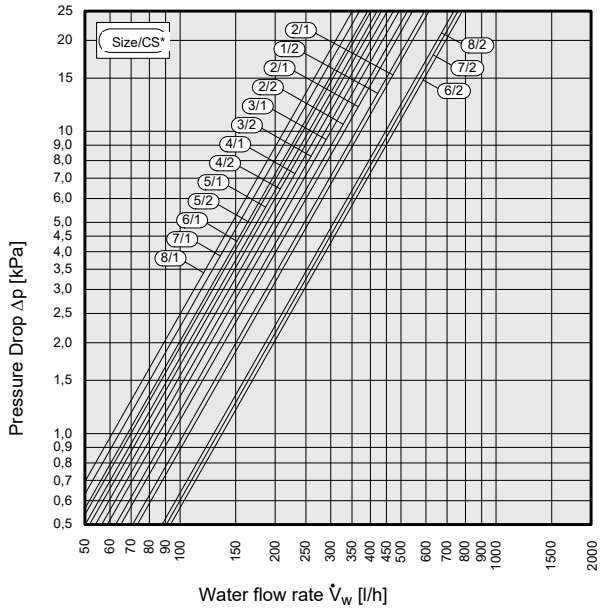

Size = model size, CS = capacity stage

\* Data for additional capacity stage 3+4 (CS3, CS4) are available on request (see page 11).

The tables on pages Page 12 to Page 64 specify heating capacity for pumped warm water 70/50 °C and air intake temperature  $t_{L1} = +20$  °C for recirculating units and  $t_{L1} = +10$  °C for mixed units as well as cooling capacity for chilled water 6/12 °C and air intake condition  $t_{L1} = +27$  °C/46 % r.h. Capacity for other operating conditions can be determined using the correction factors on Page 3.

**Sample calculation**

for recirculating Flex-Geko FCU Comfort Edition, cooling or heating with 2-pipe system with a heating capacity of min. 4.5 kW for warm water (WWP) 70/50/+15 °C and cooling capacity with chilled water 8/12 (24 °C/50 % r.h.)

**Selected unit type:**

**GF31.UWC1.A00A1**

See Page 24

Sample speed 3 = 470 m<sup>3</sup>/h

**Heating capacity** with PWW 70/50 °C and  $t_{L1} = +15$  °C

$\dot{Q}_H (70/50/+15)$  = new heating capacity  
 $f_H (70/50/+15)$  = 1.13 (s. Page 3)  
 $\dot{Q}_H (70/50/+20)$  = 4.6 (see Page 24)

$$\Rightarrow \dot{Q}_H (70/50/+15) = f_H (70/50/+15) \cdot \dot{Q}_H (70/50/+20)$$

$$\dot{Q}_H (70/50/+15) = 1.3 \cdot 4.6 \text{ kW} = \underline{\underline{5.2 \text{ kW}}}$$

**Cooling capacity** with CWW 8/12 °C and  $t_{L1} = +24$ °C/50% r.F.

$\dot{Q}_K (8/12/+24/50\%)$  = new cooling capacity  
 $f_K (8/12/+24/50\%)$  = 0.73 (s. Page 3)  
 $\dot{Q}_K (6/12/+27/46\%)$  = 2.4 (see Page 24)

$$\Rightarrow \dot{Q}_K (8/12/+24/50\%) = f_K (8/12/+24/50\%) \cdot \dot{Q}_K (6/12/+27/46\%)$$

$$\dot{Q}_K (8/12/+24/50\%) = 0.73 \cdot 2.4 \text{ kW} = \underline{\underline{1.8 \text{ kW}}}$$

**Power and current consumption**

Model size	Speed	Air volume flow [m <sup>3</sup> /h]	AC motor		EC motor	
			Capacity [W]	Current [A]	Capacity [W]	Current [A]
1	1	150	14	0.14	4	0.05
	2	220	21	0.17	5	0.06
	3	270	50	0.23	8	0.08
	4	350	55	0.25	13	0.13
	5	530	63	0.28	37	0.31
2	1	160	13	0.14	3	0.05
	2	230	21	0.18	5	0.06
	3	280	52	0.24	7	0.07
	4	360	56	0.25	12	0.11
	5	540	65	0.29	32	0.28
3	1	280	11	0.13	4	0.06
	2	350	15	0.15	6	0.07
	3	470	47	0.22	11	0.10
	4	670	60	0.28	26	0.22
	5	890	80	0.35	61	0.49
4	1	290	11	0.13	4	0.05
	2	360	15	0.17	5	0.06
	3	490	47	0.25	8	0.09
	4	720	60	0.28	21	0.19
	5	990	84	0.36	56	0.45
5	1	300	12	0.14	3	0.05
	2	370	15	0.17	5	0.06
	3	520	53	0.24	9	0.09
	4	740	67	0.29	22	0.20
	5	1010	87	0.38	61	0.50
6	1	430	25	0.28	8	0.10
	2	560	37	0.33	10	0.11
	3	750	99	0.46	16	0.17
	4	990	112	0.51	31	0.29
	5	1310	134	0.58	68	0.58
7	1	460	25	0.27	8	0.10
	2	580	37	0.33	10	0.12
	3	770	100	0.46	17	0.17
	4	1030	115	0.52	33	0.29
	5	1420	141	0.61	80	0.64
8	1	590	22	0.28	9	0.11
	2	690	30	0.33	11	0.13
	3	970	99	0.46	21	0.21
	4	1370	123	0.57	52	0.45
	5	1820	166	0.73	121	0.91

Model size	Speed	Sound power level (dB)										Sound pressure level *)			
		Octave centre frequency [Hz]								not rated	rated	not rated	rated according to		
		63	125	250	500	1000	2000	4000	8000	[dB]	dB(A)	[dB]	dB(A)	NR	NC
1	1	44	35	31	29	20	<20	<20	<20	45	30	36	21	18	14
	2	38	34	39	37	28	<20	<20	<20	43	36	34	28	25	22
	3	40	38	43	42	35	28	<20	<20	48	42	39	33	30	28
	4	37	41	48	48	41	36	28	21	52	48	43	39	36	34
	5	45	51	56	57	53	50	44	38	62	58	53	50	45	44
2	1	36	30	30	27	<20	<20	<20	<20	38	<30	29	<20	18	14
	2	35	30	38	35	28	<20	<20	<20	41	35	32	26	23	20
	3	39	39	44	42	37	27	<20	<20	48	42	39	33	29	27
	4	43	41	45	46	41	35	28	20	51	46	42	37	34	32
	5	43	49	55	56	53	49	44	38	60	58	51	49	44	43
3	1	31	33	35	27	20	<20	<20	20	39	30	30	21	19	15
	2	34	33	41	34	24	<20	<20	20	43	35	34	27	22	19
	3	44	52	47	40	34	27	<20	20	54	43	45	34	29	26
	4	43	52	57	50	45	40	31	23	59	52	50	44	39	38
	5	44	52	65	56	52	48	41	34	66	59	57	51	48	48
4	1	31	39	31	27	<20	<20	<20	<20	40	<30	31	20	17	13
	2	39	39	38	35	22	<20	<20	<20	44	35	35	26	23	20
	3	38	48	43	40	33	24	<20	<20	50	41	41	32	28	26
	4	45	52	50	51	44	39	30	23	57	51	48	42	39	37
	5	44	52	58	57	53	49	42	36	62	58	53	50	45	44
5	1	32	36	32	25	20	<20	<20	<20	39	<30	30	<20	18	14
	2	33	43	37	31	24	<20	<20	<20	45	34	36	25	18	16
	3	36	53	45	39	35	26	<20	<20	54	42	45	34	27	25
	4	56	54	52	49	46	42	31	23	60	51	51	42	37	36
	5	44	55	60	57	54	51	43	38	63	59	54	51	45	44
6	1	38	36	37	33	23	<20	<20	<20	42	33	33	24	20	18
	2	40	36	42	40	31	21	<20	<20	46	39	37	31	28	26
	3	47	53	45	44	42	36	27	20	55	46	46	38	33	32
	4	47	55	54	55	50	45	38	31	60	55	51	47	43	42
	5	52	55	61	61	57	54	48	43	66	62	57	54	49	48
7	1	44	42	35	32	23	<20	<20	<20	46	33	37	24	19	17
	2	43	43	41	38	31	22	<20	<20	48	38	39	30	26	23
	3	47	53	47	46	40	33	25	<20	56	46	47	38	34	32
	4	46	55	53	53	48	43	36	29	59	54	50	45	41	40
	5	53	56	59	60	57	53	48	42	65	62	56	53	48	47
8	1	32	36	39	33	21	<20	<20	20	42	34	33	25	20	18
	2	36	37	43	37	26	<20	<20	20	45	38	36	29	25	22
	3	46	50	51	45	37	28	<20	20	55	46	46	37	33	31
	4	44	53	59	54	48	42	33	24	61	55	52	46	42	41
	5	49	56	64	60	55	51	44	35	66	61	57	53	48	47

\*) Sound pressure level relates to a reverberation field of a 100 m<sup>3</sup> room and reverberation time of 0.5 s

  =for values used in the sample calculation, see Page 72/Page 73, Data for CS 1 and filter class G1

Model size	Speed	Sound power level (dB)										Sound pressure level *)			
		Octave centre frequency [Hz]								not rated	rated	not rated	rated according to		
		63	125	250	500	1000	2000	4000	8000	[dB]	dB(A)	[dB]	dB(A)	NR	NC
1	1	<20	<20	26	27	23	20	<20	<20	31	28	23	<20	16	13
	2	39	35	38	37	30	20	<20	20	44	37	45	28	25	23
	3	40	37	42	42	35	27	<20	20	47	42	38	33	30	28
	4	39	39	47	48	42	36	29	21	52	48	43	39	36	34
	5	44	49	56	57	53	50	44	38	61	58	52	50	46	45
2	1	32	25	31	28	20	<20	<20	<20	36	28	27	<20	15	12
	2	37	33	38	36	30	20	<20	<20	42	36	34	27	24	21
	3	36	35	41	40	36	27	<20	<20	45	41	37	32	28	26
	4	40	38	46	47	42	36	29	21	51	47	42	38	34	33
	5	44	50	56	56	53	50	44	39	61	58	52	49	44	43
3	1	35	33	33	30	22	<20	<20	20	39	30	30	22	17	14
	2	37	34	38	36	27	<20	<20	20	43	36	34	27	23	20
	3	40	48	44	43	35	27	20	<20	51	43	42	34	30	28
	4	41	49	54	52	47	40	31	22	57	52	48	43	39	38
	5	45	53	62	57	53	49	42	35	64	59	55	50	46	45
4	1	34	36	31	28	20	<20	<20	<20	39	29	30	20	17	14
	2	41	35	37	34	24	<20	<20	20	44	34	35	25	21	19
	3	41	45	44	41	33	25	<20	20	49	41	40	33	29	27
	4	42	49	51	51	45	40	31	23	56	51	47	42	38	37
	5	47	54	58	57	53	50	43	36	63	59	54	50	46	45
5	1	35	33	32	26	<20	<20	<20	<20	39	28	30	<20	15	11
	2	35	38	34	33	24	<20	<20	20	42	33	33	24	20	17
	3	39	50	42	40	36	27	20	20	51	41	42	33	28	26
	4	53	51	49	50	46	42	32	24	58	51	49	42	37	36
	5	46	51	56	56	53	51	44	38	62	59	53	51	46	45
6	1	41	34	36	32	26	<20	<20	<20	43	33	34	24	20	17
	2	40	37	42	40	32	22	<20	20	46	40	37	31	27	25
	3	44	50	48	47	39	33	24	21	54	47	45	38	35	33
	4	44	52	55	55	48	42	35	28	59	54	50	46	42	41
	5	50	57	62	61	57	52	46	40	66	62	57	53	50	49
7	1	41	39	37	31	26	<20	<20	<20	44	33	35	24	19	16
	2	41	40	41	38	32	23	<20	20	46	39	38	30	25	23
	3	44	47	48	45	39	32	25	21	53	46	44	37	33	31
	4	46	52	53	54	48	43	35	28	59	54	50	45	41	40
	5	56	56	60	61	57	54	48	42	66	62	57	54	50	49
8	1	35	35	38	34	24	<20	<20	20	42	34	33	26	21	19
	2	37	40	40	38	29	20	<20	<20	45	38	36	29	25	23
	3	43	47	48	46	39	31	21	20	53	46	44	37	34	32
	4	45	49	55	54	49	43	34	25	59	54	50	46	42	41
	5	52	57	62	59	56	51	44	37	65	61	56	53	49	48

\*) Sound pressure level relates to a reverberation field of a 100 m<sup>3</sup> room and reverberation time of 0.5 s

Data for CS 1 and filter class G1

**Sound pressure level dB(A)**

The sound pressure specifications in the tables on pages 6 - 61 and Page 70/Page 71 apply to the reverberation sound field of a room with a volume of 100 m<sup>3</sup> and reverberation time of 0.5 s.

To determine the expected sound pressure level at the installation location, refer to the A-rated sound power level in conjunction with the conversion diagram in Fig. 24.

Example:

In a conference room with dimensions of (20 x 10 x 4 m) 6 Cassette fan coil units with model size 3 should be installed. The units are to be operated at speed 2, i.e. the sound power level amounts to 35 dB(A), see page 64.

**Determining the sound pressure level**

1. Based on the room volume (800 m<sup>3</sup>), an absorption surface of approx. 100 m<sup>2</sup> Sabin is estimated in accordance with the diagram Fig. 24 "Homes, offices, hotel rooms, conference rooms".
2. The mean distance to the fan coils is assumed to be approx. 3 m and the direction coefficient to be "4", Fig. 23. The intersection of the dotted sample lines in the diagram Fig. 24 makes up the sound level difference:  $\Delta L \sim 11$  dB.
3. The anticipated A-rated sound pressure level  $L_P$  for the unit is thus:

$$L_P = L_W - \Delta L = 35 \text{ dB(A)} - 11 \text{ dB} = 24 \text{ dB(A)}$$

Increase in sound level of 6 units amounts to approx. 8 dB and is specified in the diagram Fig. 22.

Thus, the anticipated sound pressure level in the room amounts to:

$$L_{Pges.} = L_P + 8 \text{ dB} = 24 \text{ dB(A)} + 8 \text{ dB} = 32 \text{ dB(A)}$$

The value for increased requirements, as specified in Fig. 21, is thus reached.

Table „A-sound pressure level“ (LP<sup>1</sup>) specifies standard values according to VDI 2081

Room type	A-sound level dB(A)		average reverberation time s
	*	**	
<b>Apartment</b>			
(Hotel room) night	35/30	30/25	0.5
Residential rooms day	35	30	0.5
<b>Auditoriums</b>			
TV studio	30	25	1.5
Concert halls	30	25	2.0
Operas	30	25	1.5
Theatre	35	30	1.0
Cinema	40	30	1.0
Lecture halls	40	35	1.0
Reading rooms	40	35	1.0
Seminar rooms	40	35	1.0
Classrooms	40	35	1.0
<b>Offices</b>			
Conference rooms	40	35	1.0
Leisure rooms	40	35	0.5
Break rooms	40	35	0.5
small offices	40	35	0.5
Large offices	50	45	0.5
Church	35	25	3.0
Museum	40	35	1.5
Service halls	45	40	1.5
IT/Telecommunication room	55	40	1.5
Laboratory	45	40	2.0
Restaurants	40	to 55 <sup>2)</sup>	1.0
Kitchens	45	to 60 <sup>2)</sup>	1.5
Sales rooms	45	to 60 <sup>2)</sup>	1.0

Fig. 21

\* = Minimum requirements \*\* = Increased requirements  
 1) Also refer to applicable building regulations, DIN standards and VDI guidelines (e.g. DIN 4109, DIN 1946, VDI 2058)  
 2) Depending on use

**Sound level increase (dB)**

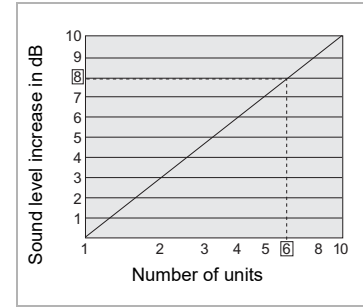

Fig. 22

**Direction coefficient**

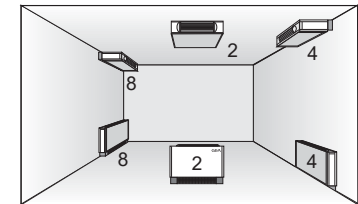

Fig. 23

- Direction coefficient 2** (hemispherical radiation)  
Unit is mounted stand-alone in the middle of a surface
- Direction coefficient 4** (quarter-spherical radiation):  
Unit borders with 2 indoor surfaces
- Direction coefficient 8** (eight-spherical radiation):  
Unit borders with 3 indoor surfaces

**Conversion of sound power level in sound pressure level**

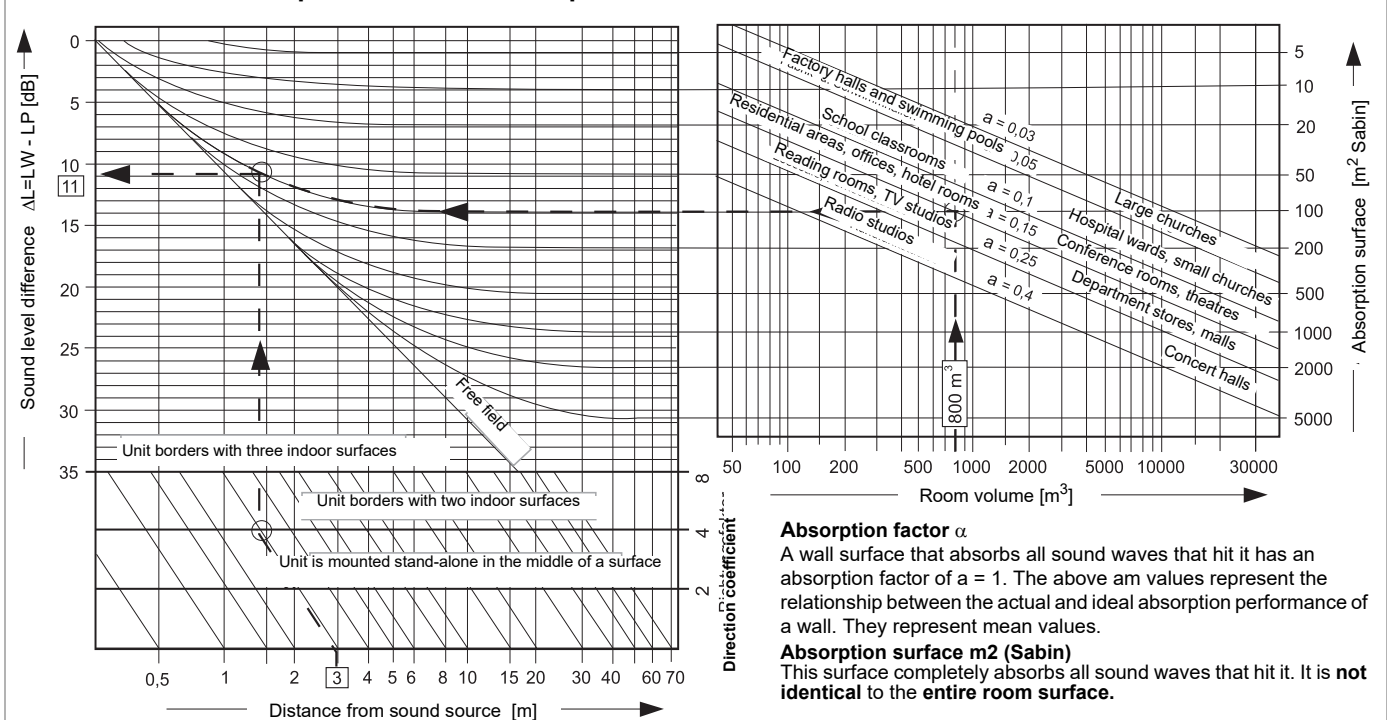

Fig. 24

**Absorption factor  $\alpha$**   
 A wall surface that absorbs all sound waves that hit it has an absorption factor of  $\alpha = 1$ . The above values represent the relationship between the actual and ideal absorption performance of a wall. They represent mean values.

**Absorption surface m<sup>2</sup> (Sabin)**  
 This surface completely absorbs all sound waves that hit it. It is not identical to the entire room surface.



**Limiting curves**

If narrower frequency components or outstanding single tones with high intensity peaks occur in a broad frequency range (e.g. on a fan), the dB(A) specification (sum level) is not sufficient as the latter does not sufficiently address the annoying noise nature. Thus, for the purposes of noise evaluation, so-called limiting curves (curves which produce the same level of inconvenience) are added. These curves also consider the combination of noise frequencies.

Although various noise-rating curves are in place, NR (Noise Rating) curves specified in Fig. 26 became internationally accepted. Today NC curves (Noise Criteria) are only used for noise rating in the USA, as specified in diagram Fig. 27.

If the observance of a particular NR or NC limiting curve is required for a room, the measured sound pressure may not exceed this limiting curve in any octave.

The sum level across all eight octave bands as per DIN is always around 7 to 10 dB higher than the value in the limiting curve. For HVAC equipment the difference of the sound pressure level lies in the medium range at 5 dB(A) because the noise spectrum does not always reach the same limiting curve in all octaves.

**Example**

The requirement of **NR 28** or **NC 26** must be observed.

The basis is the tabulated data on Page 70. In order to identify the sound pressure level in the individual octaves, the sound power values should be entered for size 3 and speed 2 in a table, see Fig. 25.

In order to obtain the sound pressure levels in the individual octaves, 11 dB must be subtracted from the sound power specifications entered in Fig. 25. The new values can now be entered in the nomograms Fig. 26 (NR) or Fig. 27 (NC).

The highest point in the NR evaluation stands at NR 20 (500 Hz) and NC 18 (500 Hz) in the NC evaluation.

**The requirement of NR 28 (NR 20 lies below NR 28) or NC 26 (NC 18 is below NC 26), is thus met.**

Octave medium frequency for size 3 and speed 2								
63	125	250	500	1000	2000	4000	8000	[Hz]
34	33	41	34	24	<20	<20	20	[dB]
-11	-11	-11	-11	-11	-11	-11	-11	[dB]
23	22	30	23	13	<9	<9	9	[dB]

Fig. 25

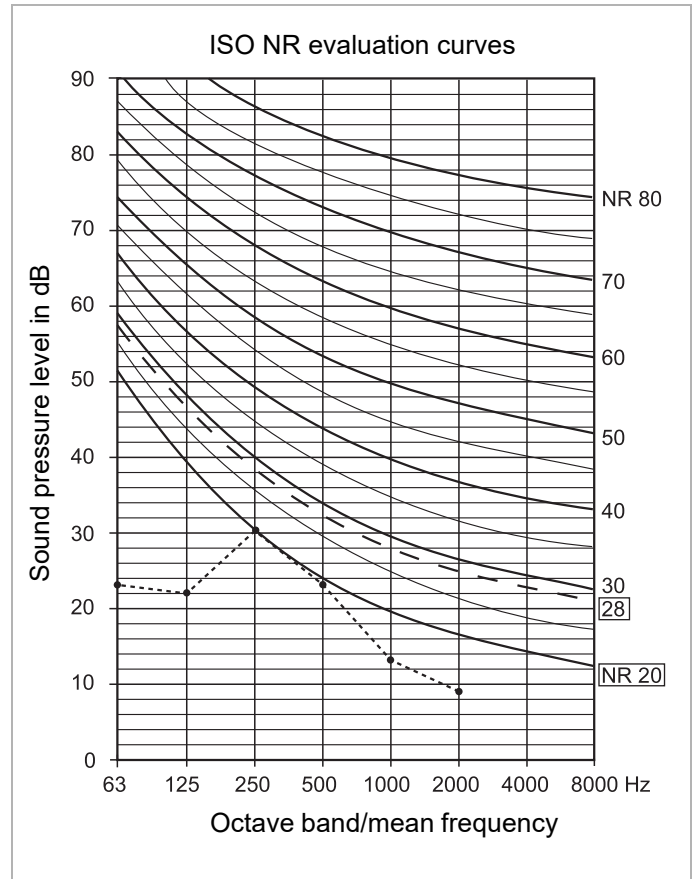

Fig. 26

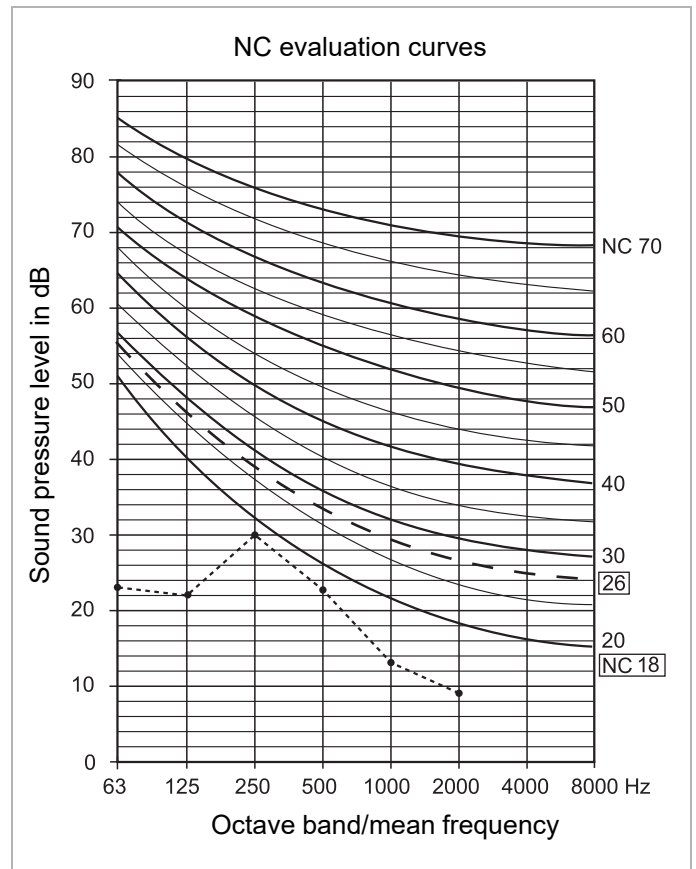

Fig. 27

**Designation of air flow**

	A	B	C	D
<b>Recirculating air</b>				
<b>Mixed air</b>				

Fig. 28

**Wall units**

Recirculating-air units with unit casing (cooling/heating)

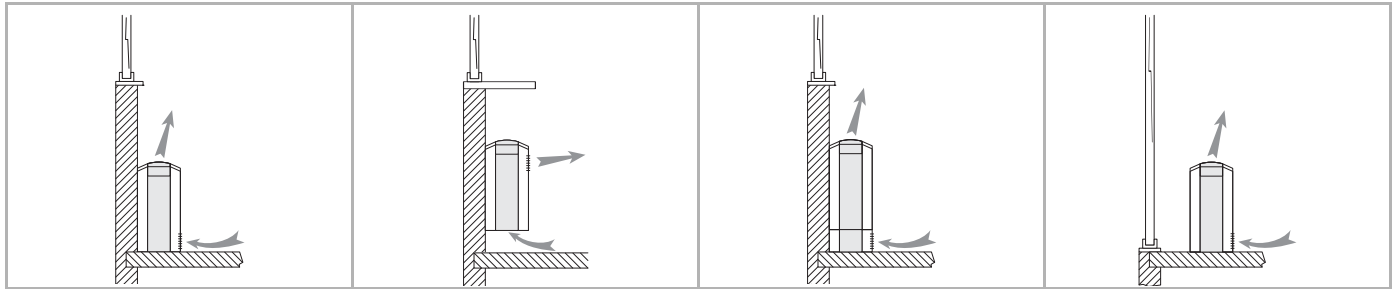

Fig. 29

Fig. 30

Fig. 31

Fig. 32

Recirculating-air units with casing by others (cooling/heating)

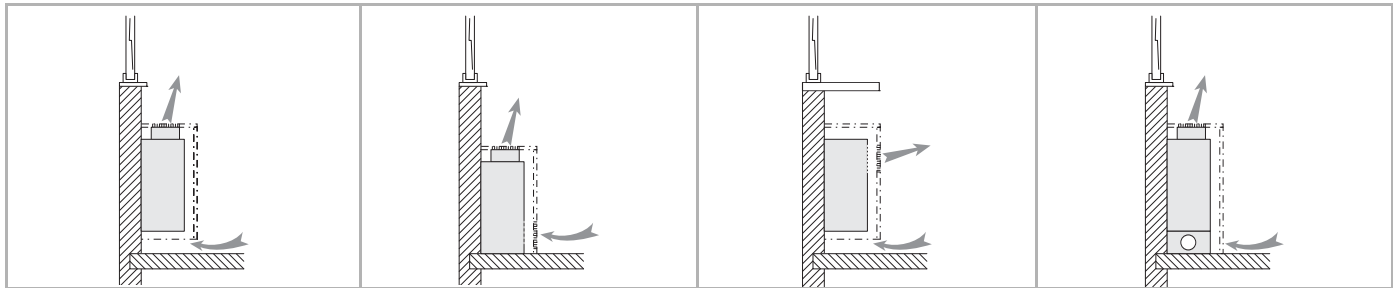

Fig. 33

Fig. 34

Fig. 35

Fig. 36

Mixed-air units (cooling/heating)

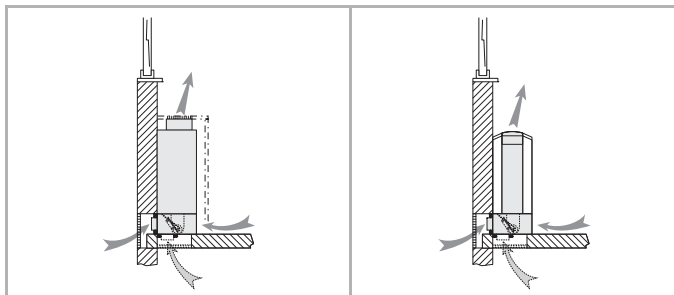

Fig. 37

Fig. 38

**Ceiling units**

Recirculating-air units with unit casing

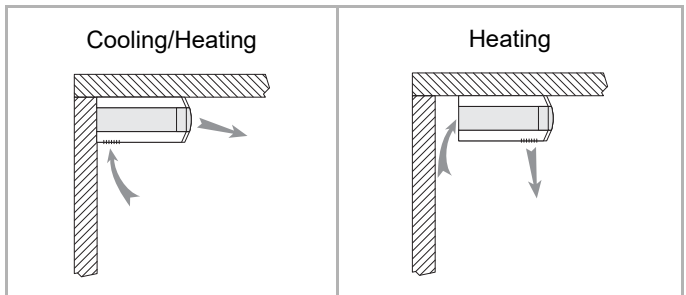

Fig. 39

Fig. 40

Recirculating-air unit with casing Recirculating-air unit with casing by others

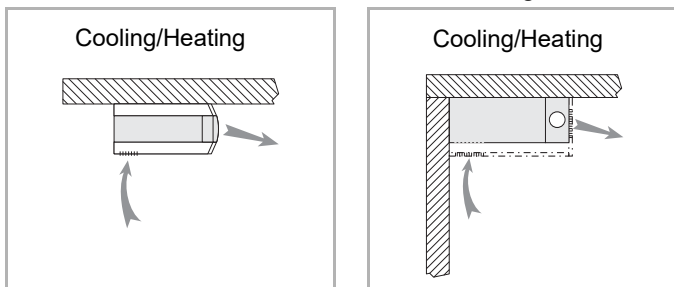

Fig. 41

Fig. 42

Mixed-air unit

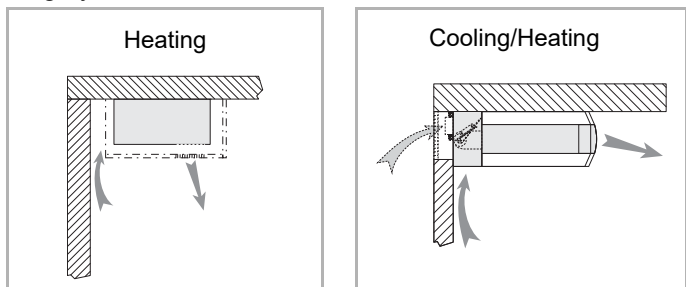
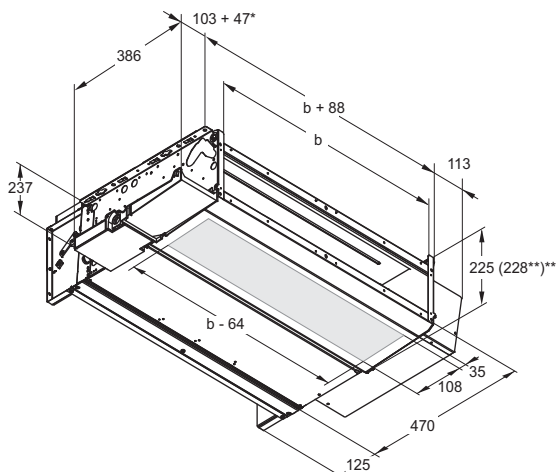

Fig. 44

### Unit for ceiling installation



- \* Space need for field-provided piping on site
- \*\* only with frontal air intake
- \*\*\* Additional space demand, if required, of 5 mm (unit height) with cooling units for pitched installation towards condensate connection side

### Lateral condensate pan for ceiling cooling units

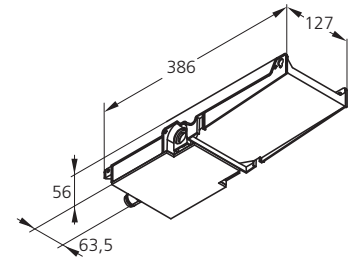

Drain connection      25 mm long  
Ø 20 mm

Fig. 45

Fig. 46

### Unit for wall installation

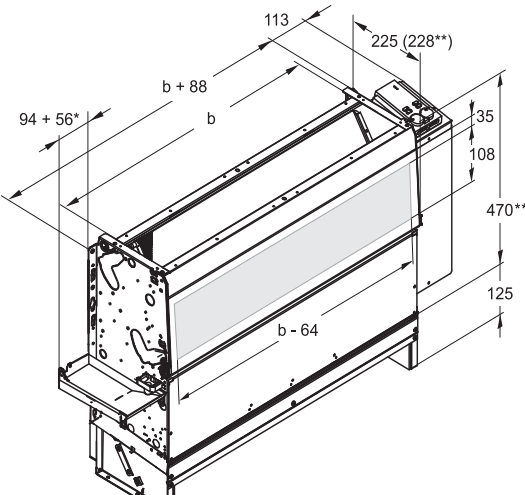

- \* Space need for field-provided piping on site
- \*\* only with frontal air intake
- \*\*\* Additional space demand, if required, of 5 mm (unit height) with cooling units for pitched installation towards condensate connection side

### Lateral drain pan for wall cooling units

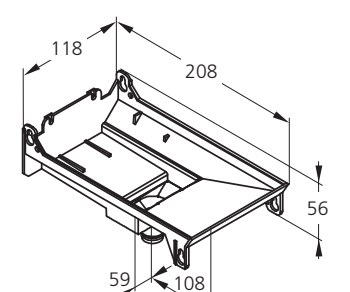

Drain connection      25 mm long  
Ø 20 mm

Fig. 47

Fig. 48

### Mounting dimensions for wall and ceiling units

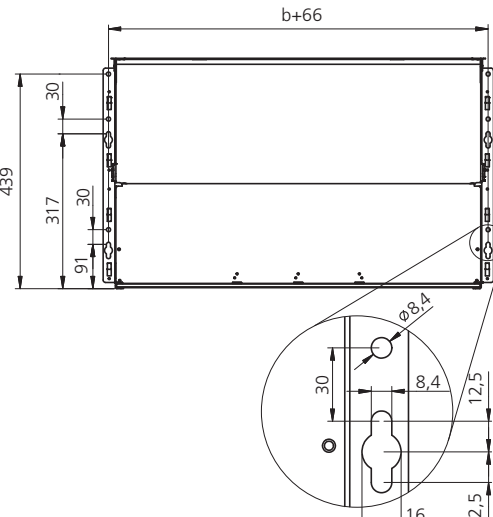

Fig. 49

### Mixed-air mechanism

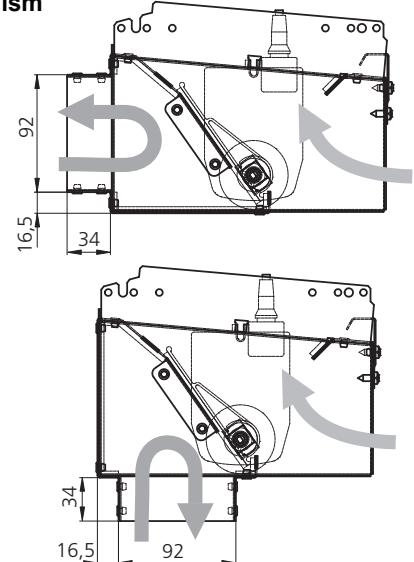
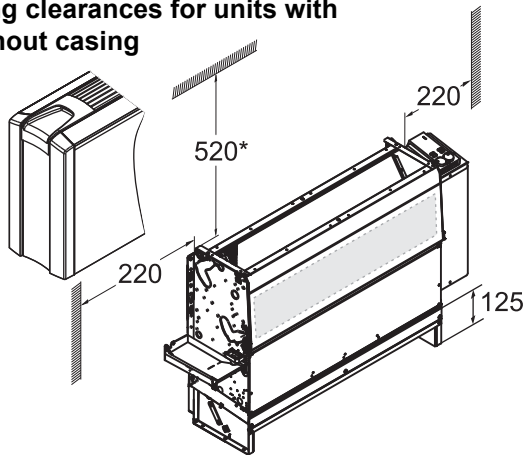

Fig. 50

Model size	1	2	3	4	5	6	7	8
b [mm]	410	560	710	860	1010	1160	1310	1460
Max. weight [kg]	17	20	25	29	32	38	42	47

**Mounting clearances for units with and without casing**



- \* - Vertical units with unit casing and rear wall for removing casing: 520 mm
- Wall units with unit casing for opening access panel: 140 mm
- Wall units with casing by others for installing flexible connection: 100-150 mm

Fig. 51

**Service opening with installation in suspended ceiling**

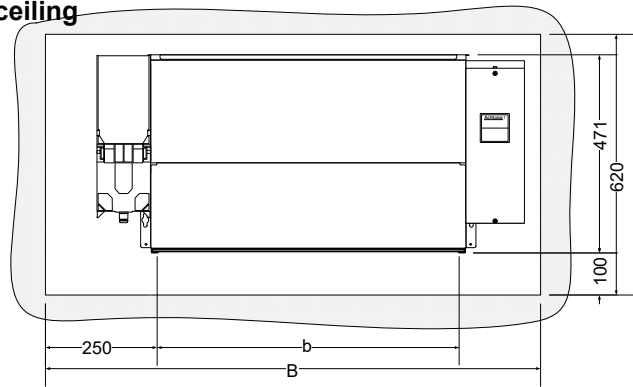

Model size	1	2	3	4	5	6	7	8
b [mm]	410	560	710	860	1010	1160	1310	1460
B [mm]	900	1050	1200	1350	1500	1650	1800	1950

Depending on unit configuration and installed air-side accessories a larger service opening may be necessary!

Fig. 52

**Medium connections (warm/chilled water)**

2-pipe system for wall and ceiling installation heat exchanger for LG 1-4, internal screw thread 1/2"

- ① - filter removal direction (unit with suction below / back)
- ② - filter removal direction (unit with front suction)

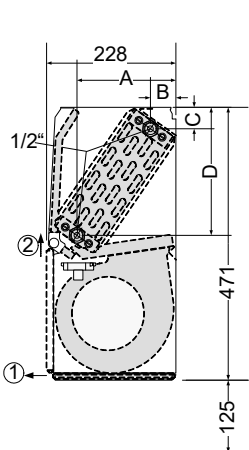

Power size	Model size	Dimension [mm]			
		A	B	C	D
1+2	1-8	172	43	38	222
	3	183	54	31	215
4	4-8	174	45	37	221
	1-7	183	54	31	215
	8	174	45	37	221

**Heat exchanger content**

Model size	Cooling circuit				Heating circuit	
	CS 1 [l]	CS 2 [l]	CS 3 [l]	CS 4 [l]	CS 1 [l]	CS 2+3 [l]
1	0.68	1.02	1.27	1.20	0.19	0.27
2	0.89	1.33	1.71	1.53	0.26	0.35
3	1.09	1.64	2.10	1.99	0.32	0.43
4	1.30	1.95	2.60	2.34	0.38	0.52
5	1.51	2.26	3.01	2.71	0.44	0.60
6	1.71	2.57	3.43	3.26	0.50	0.68
7	1.92	2.88	3.84	3.65	0.57	0.76
8	2.13	3.19	4.25	4.25	0.63	0.85

Fig. 53

**Medium connections (warm/chilled water)**

4-pipe system for wall and ceiling installation heat exchanger for LG 1-3, internal screw thread 1/2"

- ① - filter removal direction (unit with suction below / back)
- ② - filter removal direction (unit with front suction)

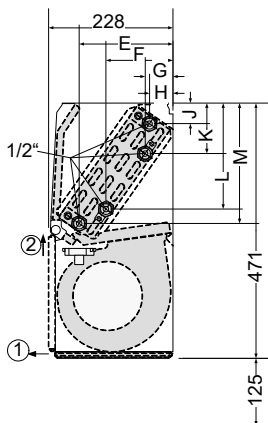

Dimension	All sizes		
	CS 1 [mm]	CS 2+3 [mm]	
E	172	183	183
F	123	137	130
G	51	36	29
H	43	54	54
J	38	31	31
K	93	81	71
L	196	224	214
M	223	215	215

**Heat exchanger content**

Model size	Cooling circuit			Heating circuit	
	CS 1 [l]	CS 2 [l]	CS 3 [l]	CS 1 [l]	CS 2+3 [l]
1	0.78	0.97	0.90	0.19	0.27
2	1.08	1.26	1.17	0.26	0.35
3	1.32	1.64	1.42	0.32	0.43
4	1.57	1.95	1.82	0.38	0.52
5	1.82	2.26	2.11	0.44	0.60
6	2.07	2.57	2.40	0.50	0.68
7	2.31	2.88	2.69	0.57	0.76
8	2.56	3.19	3.19	0.63	0.85

Fig. 54

**Medium connections (refrigerant)**

2-pipe system for wall and ceiling installation heat exchanger for LG 1

- ① - filter removal direction (unit with suction below / back)
- ② - filter removal direction (unit with front suction)

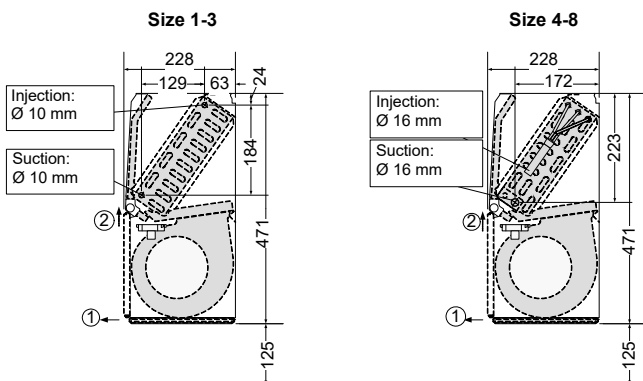

Fig. 55

**Medium connections (refrigerant/warm water)**

4-pipe system for wall and ceiling installation heat exchanger for LG 1, heating circuit internal screw thread 1/2"

- ① - filter removal direction (unit with suction below / back)
- ② - filter removal direction (unit with front suction)

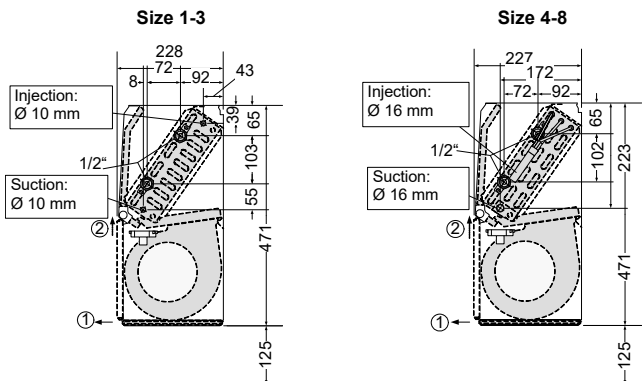
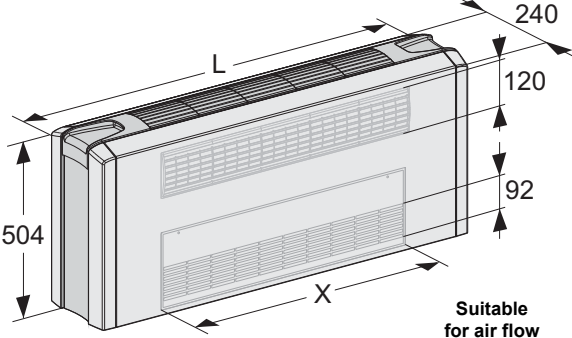
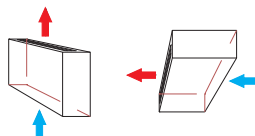
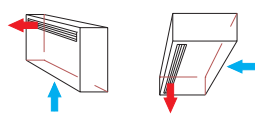
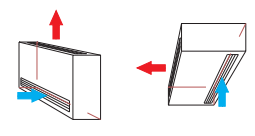
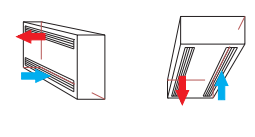
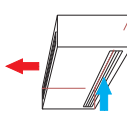
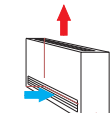

Fig. 56

 <p style="text-align: right;"><b>Suitable for air flow designation</b></p>	<p><b>Comfort casing for recirculating-air units</b></p> <ul style="list-style-type: none"> <li>– with adjustable plastic or rigid aluminium discharge grille</li> <li>– Colour white RAL 9002 with grey RAL 7035 in recess</li> </ul>																																				
<p>Wall and ceiling installation</p>  <p style="text-align: center;"><b>A</b></p>	<table border="1"> <thead> <tr> <th>Model size</th> <th>Order-Nr plastic adjustable</th> <th>Order-Nr Alu rigid</th> <th>Weight [kg]</th> </tr> </thead> <tbody> <tr><td>1</td><td>ZGF.1C012</td><td>ZGF.1C013</td><td>6.5</td></tr> <tr><td>2</td><td>ZGF.2C012</td><td>ZGF.2C013</td><td>7.5</td></tr> <tr><td>3</td><td>ZGF.3C012</td><td>ZGF.3C013</td><td>8.6</td></tr> <tr><td>4</td><td>ZGF.4C012</td><td>ZGF.4C013</td><td>9.6</td></tr> <tr><td>5</td><td>ZGF.5C012</td><td>ZGF.5C013</td><td>10.6</td></tr> <tr><td>6</td><td>ZGF.6C012</td><td>ZGF.6C013</td><td>11.6</td></tr> <tr><td>7</td><td>ZGF.7C012</td><td>ZGF.7C013</td><td>12.6</td></tr> <tr><td>8</td><td>ZGF.8C012</td><td>ZGF.8C013</td><td>13.6</td></tr> </tbody> </table>	Model size	Order-Nr plastic adjustable	Order-Nr Alu rigid	Weight [kg]	1	ZGF.1C012	ZGF.1C013	6.5	2	ZGF.2C012	ZGF.2C013	7.5	3	ZGF.3C012	ZGF.3C013	8.6	4	ZGF.4C012	ZGF.4C013	9.6	5	ZGF.5C012	ZGF.5C013	10.6	6	ZGF.6C012	ZGF.6C013	11.6	7	ZGF.7C012	ZGF.7C013	12.6	8	ZGF.8C012	ZGF.8C013	13.6
Model size	Order-Nr plastic adjustable	Order-Nr Alu rigid	Weight [kg]																																		
1	ZGF.1C012	ZGF.1C013	6.5																																		
2	ZGF.2C012	ZGF.2C013	7.5																																		
3	ZGF.3C012	ZGF.3C013	8.6																																		
4	ZGF.4C012	ZGF.4C013	9.6																																		
5	ZGF.5C012	ZGF.5C013	10.6																																		
6	ZGF.6C012	ZGF.6C013	11.6																																		
7	ZGF.7C012	ZGF.7C013	12.6																																		
8	ZGF.8C012	ZGF.8C013	13.6																																		
<p>Wall and ceiling installation</p>  <p style="text-align: center;"><b>B</b></p>	<table border="1"> <thead> <tr> <th>Model size</th> <th>Order-Nr plastic adjustable</th> <th>Weight [kg]</th> </tr> </thead> <tbody> <tr><td>1</td><td>ZGF.1C022</td><td>6.5</td></tr> <tr><td>2</td><td>ZGF.2C022</td><td>7.5</td></tr> <tr><td>3</td><td>ZGF.3C022</td><td>8.6</td></tr> <tr><td>4</td><td>ZGF.4C022</td><td>9.6</td></tr> <tr><td>5</td><td>ZGF.5C022</td><td>10.6</td></tr> <tr><td>6</td><td>ZGF.6C022</td><td>11.6</td></tr> <tr><td>7</td><td>ZGF.7C022</td><td>12.6</td></tr> <tr><td>8</td><td>ZGF.8C022</td><td>13.6</td></tr> </tbody> </table>	Model size	Order-Nr plastic adjustable	Weight [kg]	1	ZGF.1C022	6.5	2	ZGF.2C022	7.5	3	ZGF.3C022	8.6	4	ZGF.4C022	9.6	5	ZGF.5C022	10.6	6	ZGF.6C022	11.6	7	ZGF.7C022	12.6	8	ZGF.8C022	13.6									
Model size	Order-Nr plastic adjustable	Weight [kg]																																			
1	ZGF.1C022	6.5																																			
2	ZGF.2C022	7.5																																			
3	ZGF.3C022	8.6																																			
4	ZGF.4C022	9.6																																			
5	ZGF.5C022	10.6																																			
6	ZGF.6C022	11.6																																			
7	ZGF.7C022	12.6																																			
8	ZGF.8C022	13.6																																			
<p>Wall and ceiling installation</p>  <p style="text-align: center;"><b>C</b></p>	<table border="1"> <thead> <tr> <th>Model size</th> <th>Order-Nr plastic adjustable</th> <th>Order-Nr Alu rigid</th> <th>Weight [kg]</th> </tr> </thead> <tbody> <tr><td>1</td><td>ZGF.1C032</td><td>ZGF.1C033</td><td>6.5</td></tr> <tr><td>2</td><td>ZGF.2C032</td><td>ZGF.2C033</td><td>7.5</td></tr> <tr><td>3</td><td>ZGF.3C032</td><td>ZGF.3C033</td><td>8.6</td></tr> <tr><td>4</td><td>ZGF.4C032</td><td>ZGF.4C033</td><td>9.6</td></tr> <tr><td>5</td><td>ZGF.5C032</td><td>ZGF.5C033</td><td>10.6</td></tr> <tr><td>6</td><td>ZGF.6C032</td><td>ZGF.6C033</td><td>11.6</td></tr> <tr><td>7</td><td>ZGF.7C032</td><td>ZGF.7C033</td><td>12.6</td></tr> <tr><td>8</td><td>ZGF.8C032</td><td>ZGF.8C033</td><td>13.6</td></tr> </tbody> </table>	Model size	Order-Nr plastic adjustable	Order-Nr Alu rigid	Weight [kg]	1	ZGF.1C032	ZGF.1C033	6.5	2	ZGF.2C032	ZGF.2C033	7.5	3	ZGF.3C032	ZGF.3C033	8.6	4	ZGF.4C032	ZGF.4C033	9.6	5	ZGF.5C032	ZGF.5C033	10.6	6	ZGF.6C032	ZGF.6C033	11.6	7	ZGF.7C032	ZGF.7C033	12.6	8	ZGF.8C032	ZGF.8C033	13.6
Model size	Order-Nr plastic adjustable	Order-Nr Alu rigid	Weight [kg]																																		
1	ZGF.1C032	ZGF.1C033	6.5																																		
2	ZGF.2C032	ZGF.2C033	7.5																																		
3	ZGF.3C032	ZGF.3C033	8.6																																		
4	ZGF.4C032	ZGF.4C033	9.6																																		
5	ZGF.5C032	ZGF.5C033	10.6																																		
6	ZGF.6C032	ZGF.6C033	11.6																																		
7	ZGF.7C032	ZGF.7C033	12.6																																		
8	ZGF.8C032	ZGF.8C033	13.6																																		
<p>Wall and ceiling installation</p>  <p style="text-align: center;"><b>D</b></p>	<table border="1"> <thead> <tr> <th>Model size</th> <th>Order-Nr plastic adjustable</th> <th>Weight [kg]</th> </tr> </thead> <tbody> <tr><td>1</td><td>ZGF.1C042</td><td>6.5</td></tr> <tr><td>2</td><td>ZGF.2C042</td><td>7.5</td></tr> <tr><td>3</td><td>ZGF.3C042</td><td>8.6</td></tr> <tr><td>4</td><td>ZGF.4C042</td><td>9.6</td></tr> <tr><td>5</td><td>ZGF.5C042</td><td>10.6</td></tr> <tr><td>6</td><td>ZGF.6C042</td><td>11.6</td></tr> <tr><td>7</td><td>ZGF.7C042</td><td>12.6</td></tr> <tr><td>8</td><td>ZGF.8C042</td><td>13.6</td></tr> </tbody> </table>	Model size	Order-Nr plastic adjustable	Weight [kg]	1	ZGF.1C042	6.5	2	ZGF.2C042	7.5	3	ZGF.3C042	8.6	4	ZGF.4C042	9.6	5	ZGF.5C042	10.6	6	ZGF.6C042	11.6	7	ZGF.7C042	12.6	8	ZGF.8C042	13.6									
Model size	Order-Nr plastic adjustable	Weight [kg]																																			
1	ZGF.1C042	6.5																																			
2	ZGF.2C042	7.5																																			
3	ZGF.3C042	8.6																																			
4	ZGF.4C042	9.6																																			
5	ZGF.5C042	10.6																																			
6	ZGF.6C042	11.6																																			
7	ZGF.7C042	12.6																																			
8	ZGF.8C042	13.6																																			
<p>Central ceiling mounting (closed on the rear side)</p>  <p style="text-align: center;"><b>C</b></p>	<table border="1"> <thead> <tr> <th>Model size</th> <th>Order-Nr plastic adjustable</th> <th>Order-Nr Alu rigid</th> <th>Weight [kg]</th> </tr> </thead> <tbody> <tr><td>1</td><td>ZGF.1C132</td><td>ZGF.1C133</td><td>6.5</td></tr> <tr><td>2</td><td>ZGF.2C132</td><td>ZGF.2C133</td><td>7.5</td></tr> <tr><td>3</td><td>ZGF.3C132</td><td>ZGF.3C133</td><td>8.6</td></tr> <tr><td>4</td><td>ZGF.4C132</td><td>ZGF.4C133</td><td>9.6</td></tr> <tr><td>5</td><td>ZGF.5C132</td><td>ZGF.5C133</td><td>10.6</td></tr> <tr><td>6</td><td>ZGF.6C132</td><td>ZGF.6C133</td><td>11.6</td></tr> <tr><td>7</td><td>ZGF.7C132</td><td>ZGF.7C133</td><td>12.6</td></tr> <tr><td>8</td><td>ZGF.8C132</td><td>ZGF.8C133</td><td>13.6</td></tr> </tbody> </table>	Model size	Order-Nr plastic adjustable	Order-Nr Alu rigid	Weight [kg]	1	ZGF.1C132	ZGF.1C133	6.5	2	ZGF.2C132	ZGF.2C133	7.5	3	ZGF.3C132	ZGF.3C133	8.6	4	ZGF.4C132	ZGF.4C133	9.6	5	ZGF.5C132	ZGF.5C133	10.6	6	ZGF.6C132	ZGF.6C133	11.6	7	ZGF.7C132	ZGF.7C133	12.6	8	ZGF.8C132	ZGF.8C133	13.6
Model size	Order-Nr plastic adjustable	Order-Nr Alu rigid	Weight [kg]																																		
1	ZGF.1C132	ZGF.1C133	6.5																																		
2	ZGF.2C132	ZGF.2C133	7.5																																		
3	ZGF.3C132	ZGF.3C133	8.6																																		
4	ZGF.4C132	ZGF.4C133	9.6																																		
5	ZGF.5C132	ZGF.5C133	10.6																																		
6	ZGF.6C132	ZGF.6C133	11.6																																		
7	ZGF.7C132	ZGF.7C133	12.6																																		
8	ZGF.8C132	ZGF.8C133	13.6																																		
<p>Vertical stand-alone installation (with rear panel)</p>  <p style="text-align: center;"><b>C</b></p>	<table border="1"> <thead> <tr> <th>Model size</th> <th>Order-Nr plastic adjustable</th> <th>Order-Nr Alu rigid</th> <th>Weight [kg]</th> </tr> </thead> <tbody> <tr><td>1</td><td>ZGF.1C232</td><td>ZGF.1C233</td><td>6.5</td></tr> <tr><td>2</td><td>ZGF.2C232</td><td>ZGF.2C233</td><td>7.5</td></tr> <tr><td>3</td><td>ZGF.3C232</td><td>ZGF.3C233</td><td>8.6</td></tr> <tr><td>4</td><td>ZGF.4C232</td><td>ZGF.4C233</td><td>9.6</td></tr> <tr><td>5</td><td>ZGF.5C232</td><td>ZGF.5C233</td><td>10.6</td></tr> <tr><td>6</td><td>ZGF.6C232</td><td>ZGF.6C233</td><td>11.6</td></tr> <tr><td>7</td><td>ZGF.7C232</td><td>ZGF.7C233</td><td>12.6</td></tr> <tr><td>8</td><td>ZGF.8C232</td><td>ZGF.8C233</td><td>13.6</td></tr> </tbody> </table>	Model size	Order-Nr plastic adjustable	Order-Nr Alu rigid	Weight [kg]	1	ZGF.1C232	ZGF.1C233	6.5	2	ZGF.2C232	ZGF.2C233	7.5	3	ZGF.3C232	ZGF.3C233	8.6	4	ZGF.4C232	ZGF.4C233	9.6	5	ZGF.5C232	ZGF.5C233	10.6	6	ZGF.6C232	ZGF.6C233	11.6	7	ZGF.7C232	ZGF.7C233	12.6	8	ZGF.8C232	ZGF.8C233	13.6
Model size	Order-Nr plastic adjustable	Order-Nr Alu rigid	Weight [kg]																																		
1	ZGF.1C232	ZGF.1C233	6.5																																		
2	ZGF.2C232	ZGF.2C233	7.5																																		
3	ZGF.3C232	ZGF.3C233	8.6																																		
4	ZGF.4C232	ZGF.4C233	9.6																																		
5	ZGF.5C232	ZGF.5C233	10.6																																		
6	ZGF.6C232	ZGF.6C233	11.6																																		
7	ZGF.7C232	ZGF.7C233	12.6																																		
8	ZGF.8C232	ZGF.8C233	13.6																																		

Model size	1	2	3	4	5	6	7	8
L (mm)	840	990	1140	1290	1440	1590	1740	1890
X (mm)	450	600	750	900	1050	1200	1350	1500

**Comfort casing with foot cover for recirculating-air units**

- with adjustable plastic or rigid aluminium discharge grille
- Colour white RAL 9002 with grey RAL 7035 in recess

Suitable for air flow designation

Wall and ceiling installation

**A**

Model size	Order-Nr plastic adjustable	Order-Nr Alu rigid	Weight [kg]
1	ZGF.1C052	ZGF.1C053	7.1
2	ZGF.2C052	ZGF.2C053	8.2
3	ZGF.3C052	ZGF.3C053	9.3
4	ZGF.4C052	ZGF.4C053	10.3
5	ZGF.5C052	ZGF.5C053	11.4
6	ZGF.6C052	ZGF.6C053	12.5
7	ZGF.7C052	ZGF.7C053	13.6
8	ZGF.8C052	ZGF.8C053	14.8

Wall and ceiling installation

**B**

Model size	Order-Nr plastic adjustable	Weight [kg]
1	ZGF.1C062	7.1
2	ZGF.2C062	8.2
3	ZGF.3C062	9.3
4	ZGF.4C062	10.3
5	ZGF.5C062	11.4
6	ZGF.6C062	12.5
7	ZGF.7C062	13.6
8	ZGF.8C062	14.8

**Comfort unit casing with foot casing and air intake grille for recirculating and mixed units**

- with adjustable plastic or rigid aluminium discharge grille
- Colour white RAL 9002 with grey RAL 7035 in recess

Suitable for air flow designation

Wall and ceiling installation

**A**

Model size	Order-Nr plastic adjustable	Order-Nr Alu rigid	Weight [kg]
1	ZGF.1C072	ZGF.1C073	8.1
2	ZGF.2C072	ZGF.2C073	9.2
3	ZGF.3C072	ZGF.3C073	10.3
4	ZGF.4C072	ZGF.4C073	11.4
5	ZGF.5C072	ZGF.5C073	12.4
6	ZGF.6C072	ZGF.6C073	13.5
7	ZGF.7C072	ZGF.7C073	14.6
8	ZGF.8C072	ZGF.8C073	15.8

Wall and ceiling installation

**B**

Model size	Order-Nr plastic adjustable	Weight [kg]
1	ZGF.1C082	8.1
2	ZGF.2C082	9.2
3	ZGF.3C082	10.3
4	ZGF.4C082	11.4
5	ZGF.5C082	12.4
6	ZGF.6C082	13.5
7	ZGF.7C082	14.6
8	ZGF.8C082	15.8

Model size	1	2	3	4	5	6	7	8
L (mm)	840	990	1140	1290	1440	1590	1740	1890
X (mm)	450	600	750	900	1050	1200	1350	1500

### What is Geko-Drive?

Geko-Drive is a modern motorized discharge profile for optimization of flow velocity and air throw in cooling mode. Depending on fan speed (stage) as well as supply and room temperature, the main function is to improve air throw and indoor air flow and thence enhance room comfort.

Discharge profile is performed for most favorable air flow and reaches optimal discharge velocity even at low speed or speed stage.

- Geko-Drive is delivered already mounted by factory
- With unit casing for an optimum air routing system
- MATRIX 4000 controlling for automatic air throw adjustment
- Available for only cooling or cooling and heating units using water as medium

Model size	Order No.		Weight [kg]
	Left	Right	
1	ZGF.1A412	ZGF.1A422	1.9
2	ZGF.2A412	ZGF.2A422	2.4
3	ZGF.3A412	ZGF.3A422	2.9
4	ZGF.4A412	ZGF.4A422	3.4
5	ZGF.5A412	ZGF.5A422	3.9
6	ZGF.6A412	ZGF.6A422	4.4
7	ZGF.7A412	ZGF.7A422	4.9
8	ZGF.8A412	ZGF.8A422	5.4

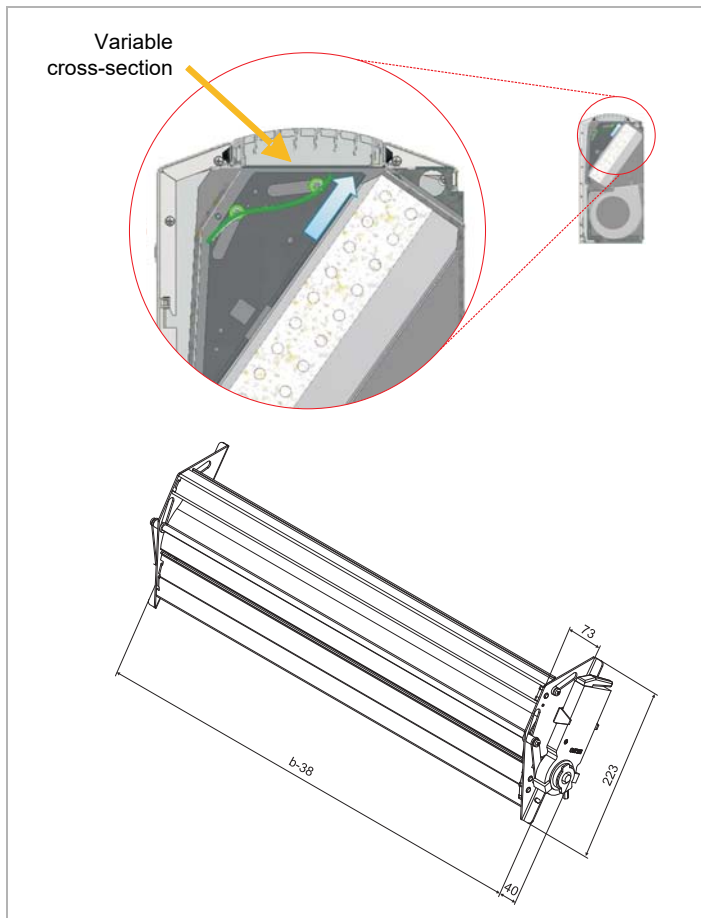

Fig. 57

### Example (computational fluid dynamics CFD):

Due to low cooling demand in part-load range, automatic regulation selects low fan speed (stage). This can lead to a situation when air discharge velocity is not adequate to reach an effective air throw and penetration depth up to ceiling. In an extreme case this can even lead an airside short circuit, when cold air is discharged from unit, falls down due to a missing impulse and sucked again into the unit. To avoid this, the speed (stage) would have to be increased which is not really desirable in terms of possibly low noise level and current draw.

Geko-Drive works against above-mentioned scenario by reducing air discharge cross-section using continuous regulation, in such a way air flow velocity is increased without having to raise speed (stage) and at the same time air flow is evenly distributed on walls and ceiling (Coanda-Effect). Thus, an appreciable increase in penetration depth of the room can be reached – as far as comfort is concerned – and non-critical temperature and velocity-related distribution in occupied zone are ensured.

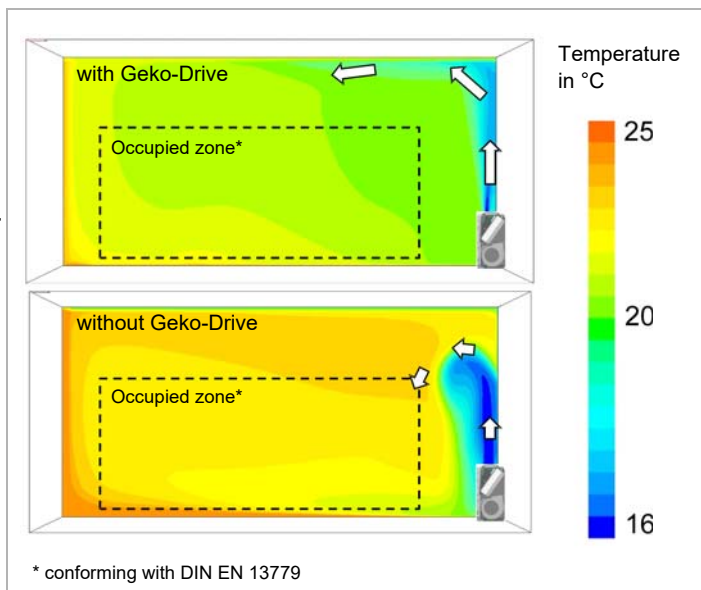

Fig. 58

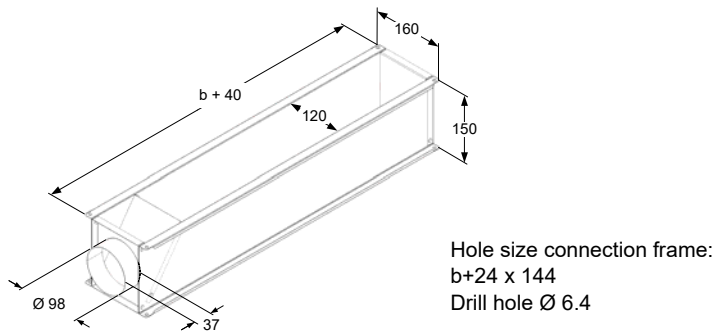

Fig. 59

### Discharge plenum with primary air connection

DN 100

Model size	Order No.		Weight [kg]
	not insulated	insulated	
1	ZGF.1A012	ZGF.1A022	1.5/1.9
2	ZGF.2A012	ZGF.2A022	1.7/1.8
3	ZGF.3A012	ZGF.3A022	1.9/2.0
4	ZGF.4A012	ZGF.4A022	2.2/2.3
5	ZGF.5A012	ZGF.5A022	2.5/2.6
6	ZGF.6A012	ZGF.6A022	2.7/2.9
7	ZGF.7A012	ZGF.7A022	3.0/3.2

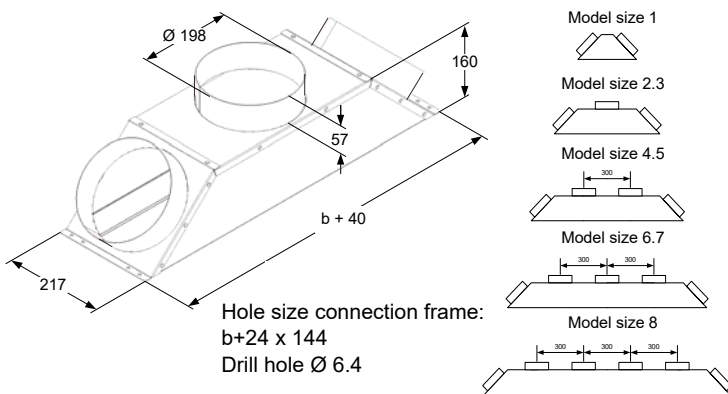

Fig. 60

### Discharge plenum with round fitting

DN 200

Model size	Order No.		Weight [kg]
	not insulated	insulated	
1	ZGF.1A032	ZGF.1A042	1.8/1.9
2	ZGF.2A032	ZGF.2A042	2.5/2.6
3	ZGF.3A032	ZGF.3A042	3.0/3.1
4	ZGF.4A032	ZGF.4A042	3.7/3.8
5	ZGF.5A032	ZGF.5A042	4.3/4.4
6	ZGF.6A032	ZGF.6A042	4.9/5.1
7	ZGF.7A032	ZGF.7A042	5.5/5.7
8	ZGF.8A032	ZGF.8A042	6.1/6.3

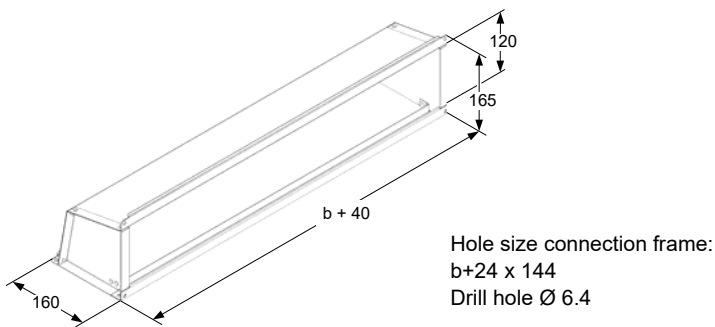

Fig. 61

### Discharge bend

Model size	Order No.		Weight [kg]
	not insulated	insulated	
1	ZGF.1A052	ZGF.1A062	1.2/1.3
2	ZGF.2A052	ZGF.2A062	1.5/1.6
3	ZGF.3A052	ZGF.3A062	1.7/1.8
4	ZGF.4A052	ZGF.4A062	2.0/2.1
5	ZGF.5A052	ZGF.5A062	2.3/2.4
6	ZGF.6A052	ZGF.6A062	2.5/2.6
7	ZGF.7A052	ZGF.7A062	2.8/2.9
8	ZGF.8A052	ZGF.8A062	3.1/3.2

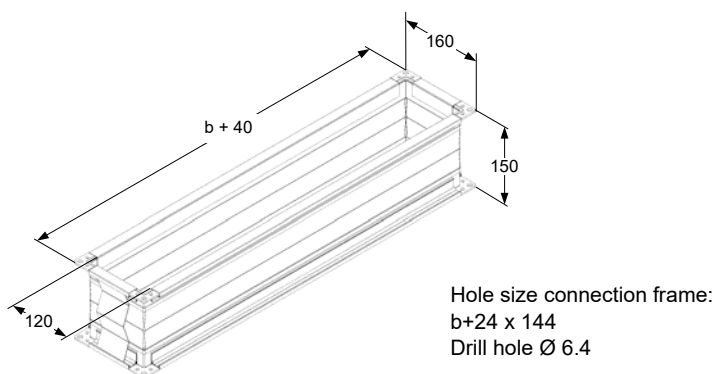

Fig. 62

### flexible connection

Model size	Order No.		Weight [kg]
	Air intake *	Discharge	
1	ZGF.1A111	ZGF.1A112	1.5
2	ZGF.2A111	ZGF.2A112	2.0
3	ZGF.3A111	ZGF.3A112	2.5
4	ZGF.4A111	ZGF.4A112	3.0
5	ZGF.5A111	ZGF.5A112	3.5
6	ZGF.6A111	ZGF.6A112	4.0
7	ZGF.7A111	ZGF.7A112	4.5
8	ZGF.8A111	ZGF.8A112	5.0

\* Transition piece ZGF#A131 required

Model size	1	2	3	4	5	6	7	8
b (mm)	410	560	710	860	1010	1160	1310	1460



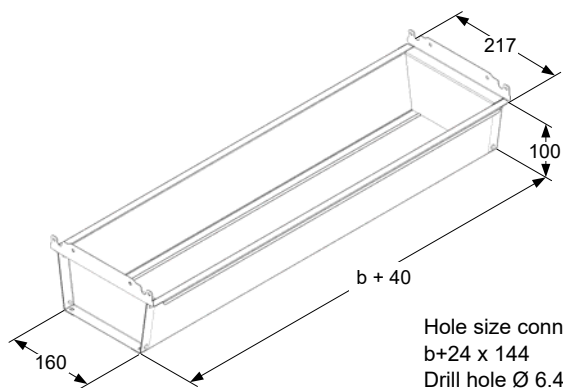

Fig. 63

**Transition piece for intake flexible connection, telescopic and sound-attenuator connection**

Model size	Order No.	Weight [kg]
1	ZGF.1A131	1.1
2	ZGF.2A131	1.3
3	ZGF.3A131	1.5
4	ZGF.4A131	1.7
5	ZGF.5A131	1.9
6	ZGF.6A131	2.1
7	ZGF.7A131	2.2
8	ZGF.8A131	2.4

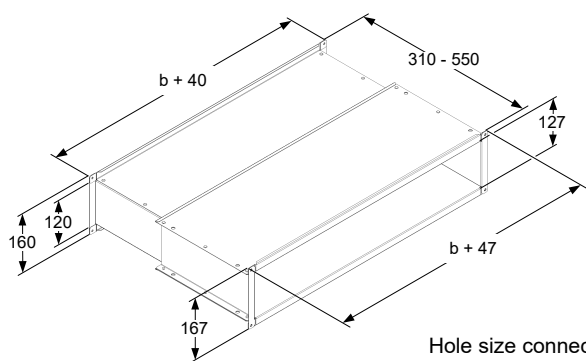

Fig. 64

**Telescopic connection**

not insulated

Model size	Order No.		Weight [kg]
	Air intake *	Discharge	
1	ZGF.1A151	ZGF.1A152	6.0
2	ZGF.2A151	ZGF.2A152	7.6
3	ZGF.3A151	ZGF.3A152	9.1
4	ZGF.4A151	ZGF.4A152	10.7
5	ZGF.5A151	ZGF.5A152	12.2
6	ZGF.6A151	ZGF.6A152	13.8
7	ZGF.7A151	ZGF.7A152	15.3
8	ZGF.8A151	ZGF.8A152	16.9

\* Transition piece ZGF#A131 required

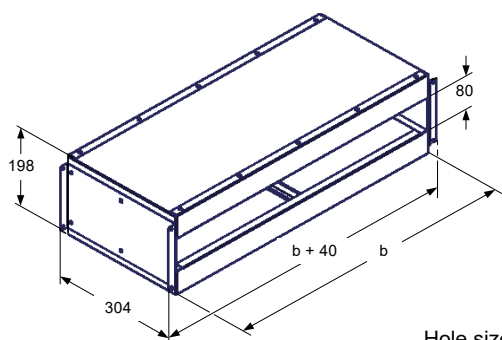

Fig. 65

**Sound attenuator fitting**

Discharge sound attenuator connection  
Intake sound attenuator connection for recirculating-air units

Model size	Order No.		Weight [kg]
	Air intake *	Discharge	
1	ZGF.1A211	ZGF.1A212	6.9
2	ZGF.2A211	ZGF.2A212	8.8
3	ZGF.3A211	ZGF.3A212	10.7
4	ZGF.4A211	ZGF.4A212	12.8
5	ZGF.5A211	ZGF.5A212	14.5
6	ZGF.6A211	ZGF.6A212	16.5
7	ZGF.7A211	ZGF.7A212	18.4
8	ZGF.8A211	ZGF.8A212	20.3

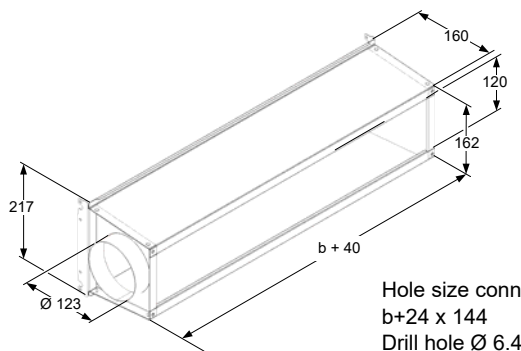
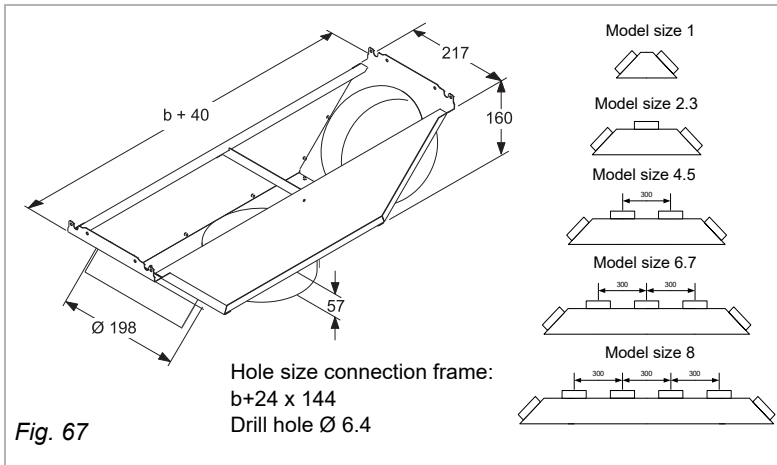

Fig. 66

**Air intake plenum with primary air connection**  
DN 125, not insulated

Model size	Order No.	Weight [kg]
1	ZGF.1A011	1.6
2	ZGF.2A011	1.8
3	ZGF.3A011	2.1
4	ZGF.4A011	2.4
5	ZGF.5A011	2.6
6	ZGF.6A011	2.9
7	ZGF.7A011	3.2
8	ZGF.8A011	3.4

Model size	1	2	3	4	5	6	7	8
b (mm)	410	560	710	860	1010	1160	1310	1460



### Air intake plenum with round connection

DN 200, not insulated

Model size	Order No.	Weight [kg]
1	ZGF.1A031	1.9
2	ZGF.2A031	2.5
3	ZGF.3A031	3.0
4	ZGF.4A031	3.6
5	ZGF.5A031	4.1
6	ZGF.6A031	4.7
7	ZGF.7A031	5.3
8	ZGF.8A031	5.9

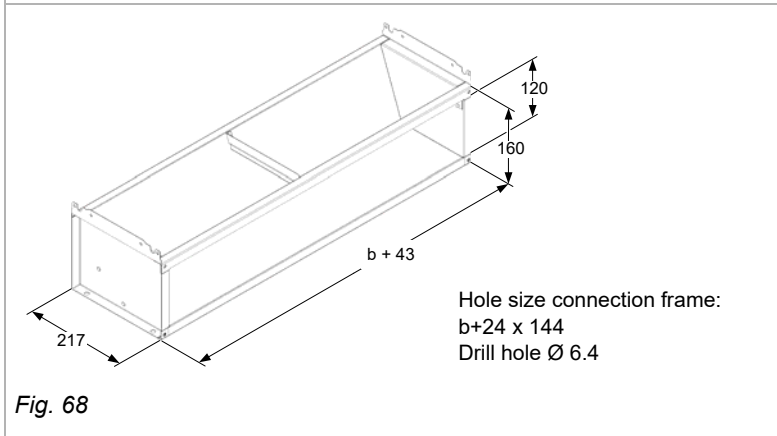

### Air intake bend

not insulated

Model size	Order No.	Weight [kg]
1	ZGF.1A051	1.7
2	ZGF.2A051	2.0
3	ZGF.3A051	2.3
4	ZGF.4A051	2.6
5	ZGF.5A051	2.9
6	ZGF.6A051	3.2
7	ZGF.7A051	3.5
8	ZGF.8A051	3.8

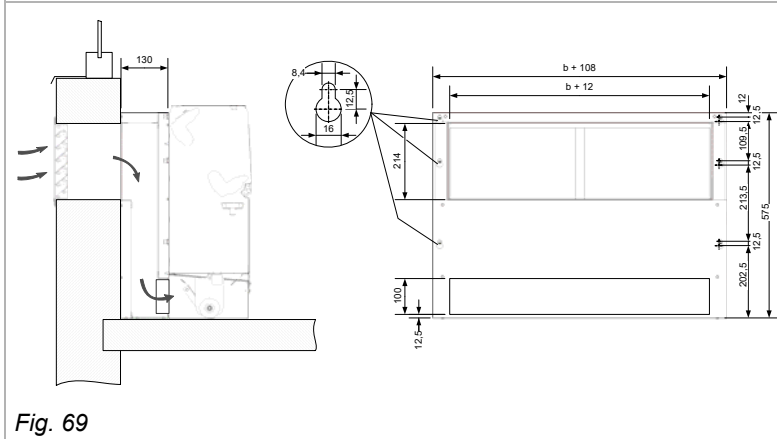

### Intake sound attenuator for mixed-air units

Model size	Order No.	Weight [kg]
1	ZGF.1A231	8.5
2	ZGF.2A231	10.0
3	ZGF.3A231	11.6
4	ZGF.4A231	13.1
5	ZGF.5A231	14.9
6	ZGF.6A231	16.5
7	ZGF.7A231	18.1
8	ZGF.8A231	19.7

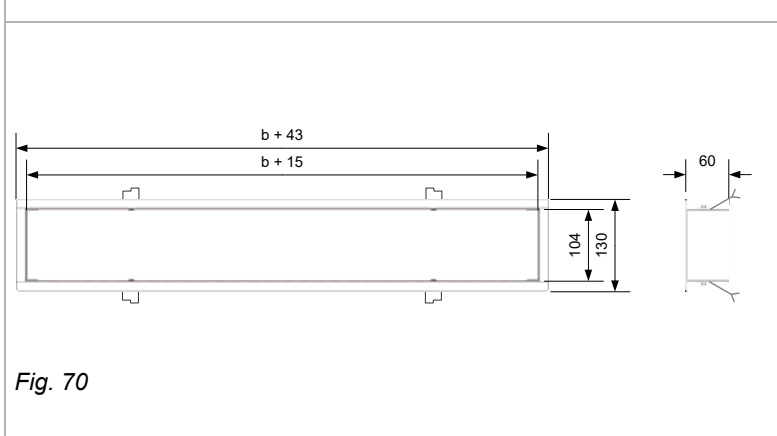

### Frame for in-wall installation for outside air intake connection

Model size	Order No.	Weight [kg]
1	ZGF.1A311	0.7
2	ZGF.2A311	0.9
3	ZGF.3A311	1.1
4	ZGF.4A311	1.2
5	ZGF.5A311	1.4
6	ZGF.6A311	1.6
7	ZGF.7A311	1.8
8	ZGF.8A311	1.9

Model size	1	2	3	4	5	6	7	8
b (mm)	410	560	710	860	1010	1160	1310	1460

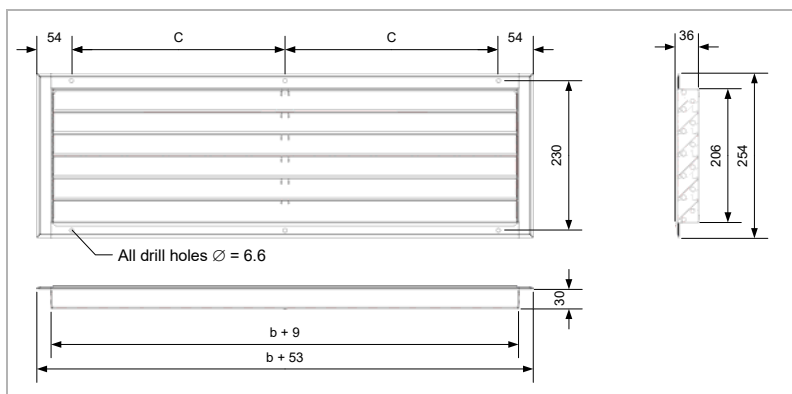

Fig. 71

**External weather grill**

RAL 9006 painted

Model size	Order No.	Weight [kg]
1	ZGF.1A331	1.9
2	ZGF.2A331	2.6
3	ZGF.3A331	3.2
4	ZGF.4A331	3.8
5	ZGF.5A331	4.4
6	ZGF.6A331	5.0
7	ZGF.7A331	5.6
8	ZGF.8A331	6.2

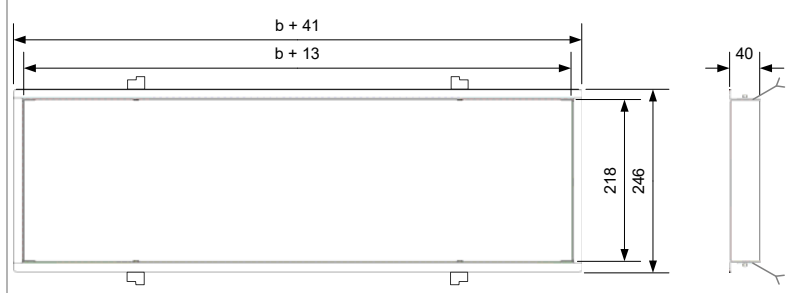

Fig. 72

**Frame for in-wall installation for weather-protection grille**

Model size	Order No.	Weight [kg]
1	ZGF.1A371	0.6
2	ZGF.2A371	0.8
3	ZGF.3A371	0.9
4	ZGF.4A371	1.0
5	ZGF.5A371	1.1
6	ZGF.6A371	1.1
7	ZGF.7A371	1.2
8	ZGF.8A371	1.4

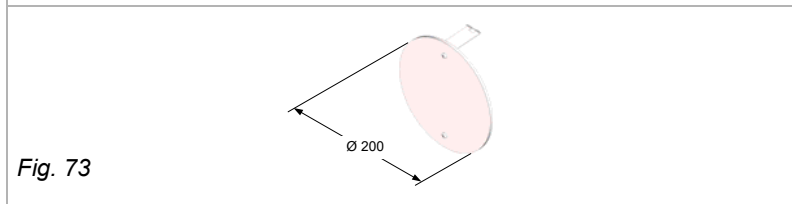

Fig. 73

**Cover cap for round fitting**

DN 200, insulated

Model size	Order No.
1 - 8	ZGF.0A713

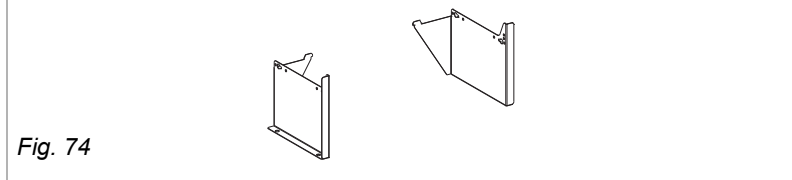

Fig. 74

**Unit feet for recirculating-air units**

Model size	Order No.
1 - 8	ZGF.0A913

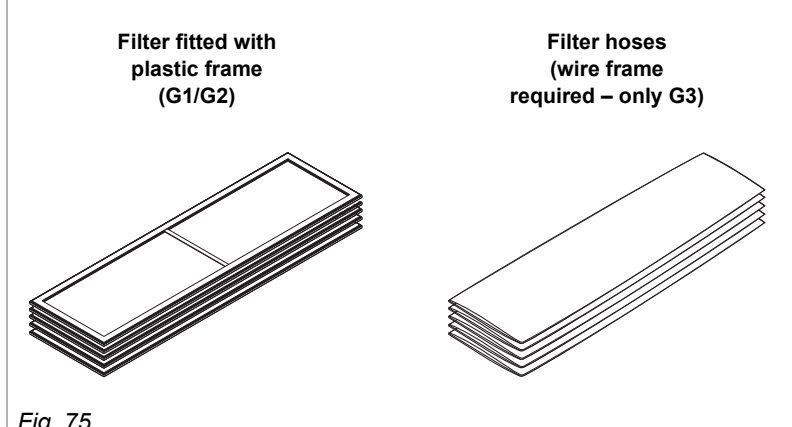

Fig. 75

**Spare filter set**

G1/G2 - Complete filter; G3 - filter hoses;  
1 set = 5 pieces

Model size	Order No.		
	G1	G2	G3
1	ZGF.1A813	ZGF.1A823	ZGF.1A833
2	ZGF.2A813	ZGF.2A823	ZGF.2A833
3	ZGF.3A813	ZGF.3A823	ZGF.3A833
4	ZGF.4A813	ZGF.4A823	ZGF.4A833
5	ZGF.5A813	ZGF.5A823	ZGF.5A833
6	ZGF.6A813	ZGF.6A823	ZGF.6A833
7	ZGF.7A813	ZGF.7A823	ZGF.7A833
8	ZGF.8A813	ZGF.8A823	ZGF.8A833

Model size	1	2	3	4	5	6	7	8
b (mm)	410	560	710	860	1010	1160	1310	1460
c (mm)	177.5	252.5	327.5	402.5	477.5	552.5	627.5	702.5

**2-Point open/close operation**

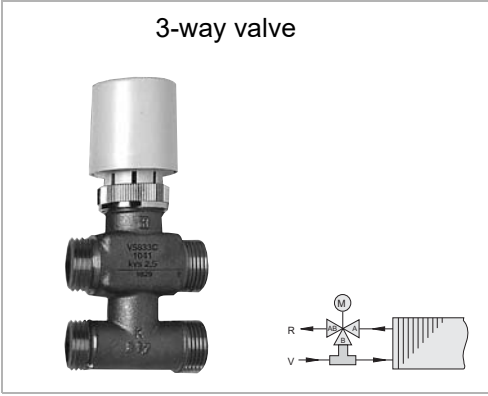
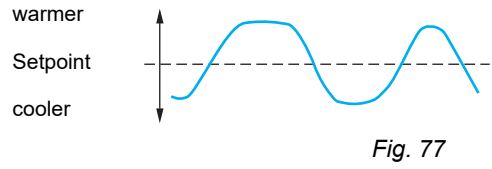
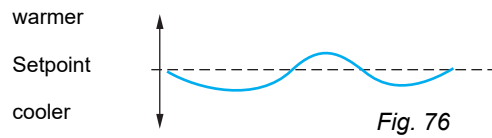

Fig. 78: (2-point open/close operation)



**2-Point open/close operation**

Fig. 76

Temperature is obtained in room with 2-point control mode.

Fig. 77

Temperature is obtained in the centre with 2-point control behavior at air outlet.

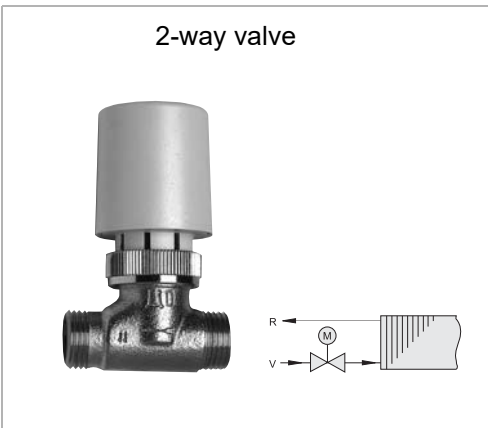

Fig. 81: (2-point open/close operation)

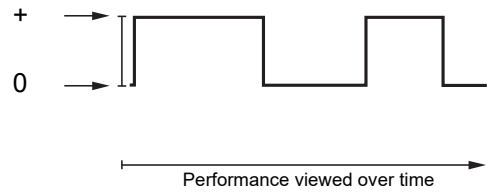
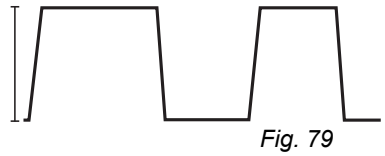

Fig. 79

The valve is either open or closed.

Fig. 80

Set command for valve  
+ = valve "open"  
0 = valve "closed"

Fig. 80

**3-Point modulating operation**

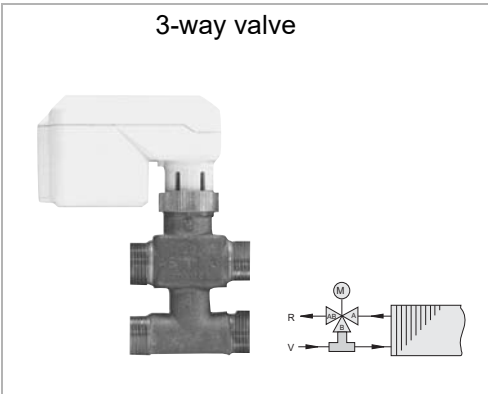
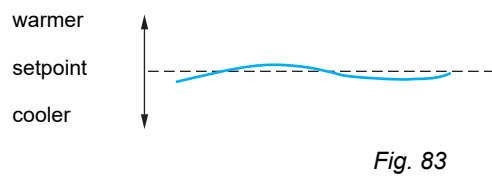
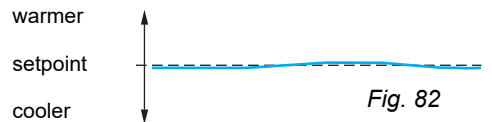

Fig. 84: (3-point modulating operation)



**3-Point modulating operation**

Fig. 82

Room temperature is controlled with 3-point control mode.

Fig. 83

Temperature is controlled in centre in 3-point mode at air outlet.

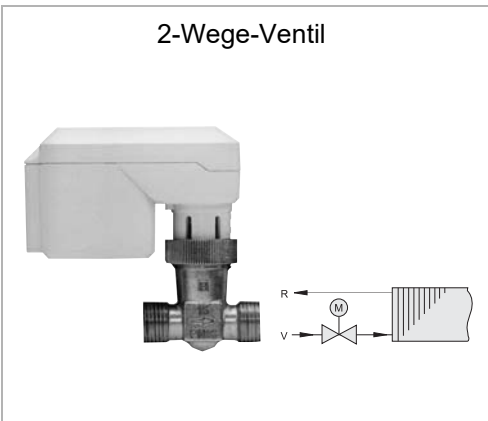

Fig. 87: (3-point modulating operation)

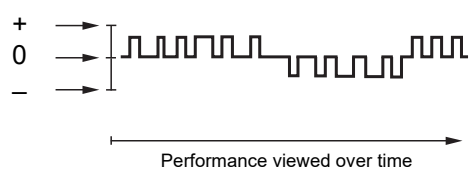
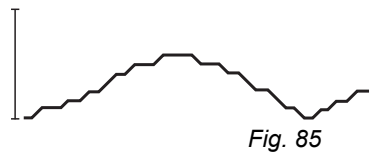

Fig. 85

The valve setting corresponds in percent to the mass flow (0 ... 100 %)

Fig. 86

Set command for valve  
+ = valve direction "open"  
- = valve direction "close"

Fig. 86

The following selection table presents all available valves models with main features and compatible control equipment.

The following symbols are used:

„✓“ = Valve type compatible with the corresponding control panel or electric equipment.

„–“ = Valve type not compatible with the corresponding control panel or electrical equipment.

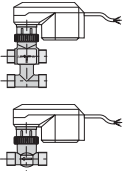
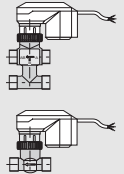
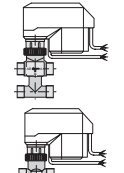
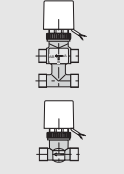
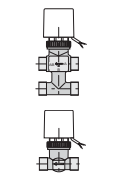
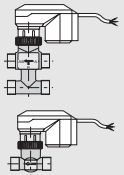
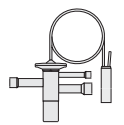
Valve Type	Function type	Control type	Voltage	Compatible control equipment				Field-provided controls	Catalogue Page
				MATRIX 2000	MATRIX 3000	MATRIX 4000	Thermostat switch		
	R	3 point (modulating)	230 V~	✓  (only 2-pipe system)	✓	✓	–	✓	87
	N	3 point (modulating)	24 V~	✓  (only 2-pipe system; transformer by others required)	✓  (transformer by others required)	✓  (transformer by others required)	–	✓	87
	C	3 point (modulating)  (2 volt free auxiliary switches)	230 V~	✓  (only 2-pipe system)	✓	✓	–	✓	88
	T	2 point (modulating)	230 V~	✓	✓	✓	✓	✓	89
	Q	2 point (modulating)	24 V~	✓  (transformer by others required)	✓  (transformer by others required)	✓  (transformer by others required)	–	✓	89
	S	continuous	24 V~ (analog-signal 0..10 V)	–	–	–	–	✓	89
	E	continuous	W/o additional power source	self-acting valve (can not be regulated)					90

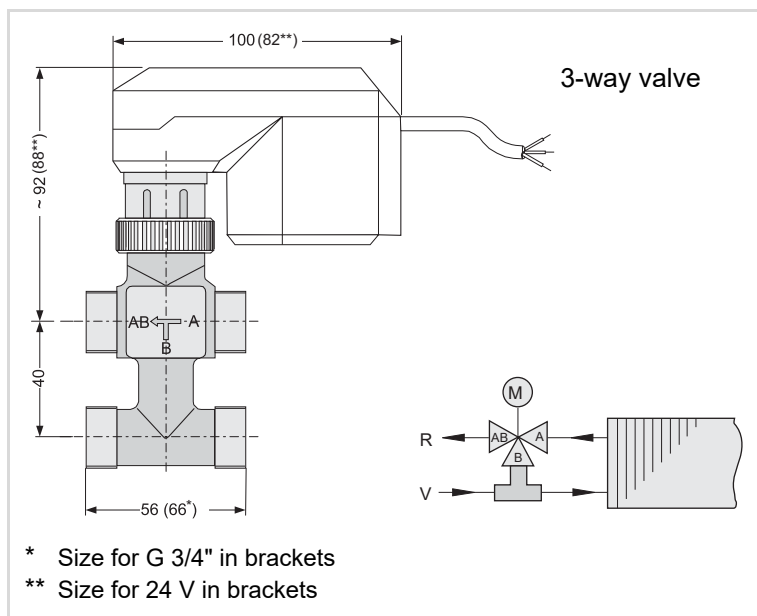

Fig. 88

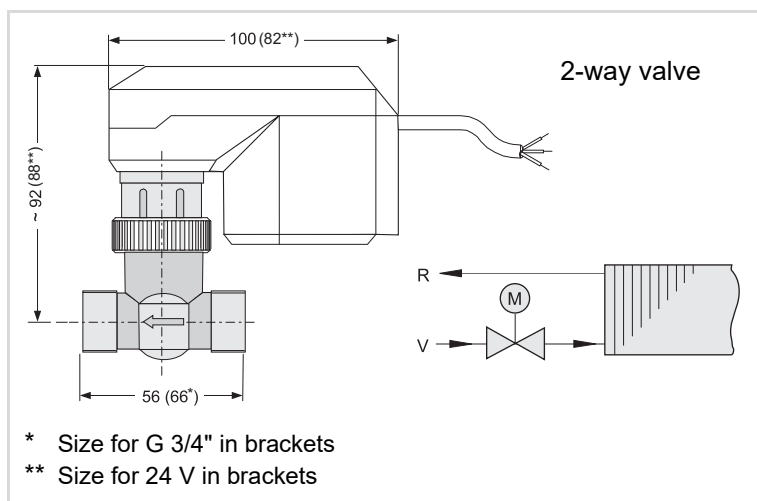

Fig. 89

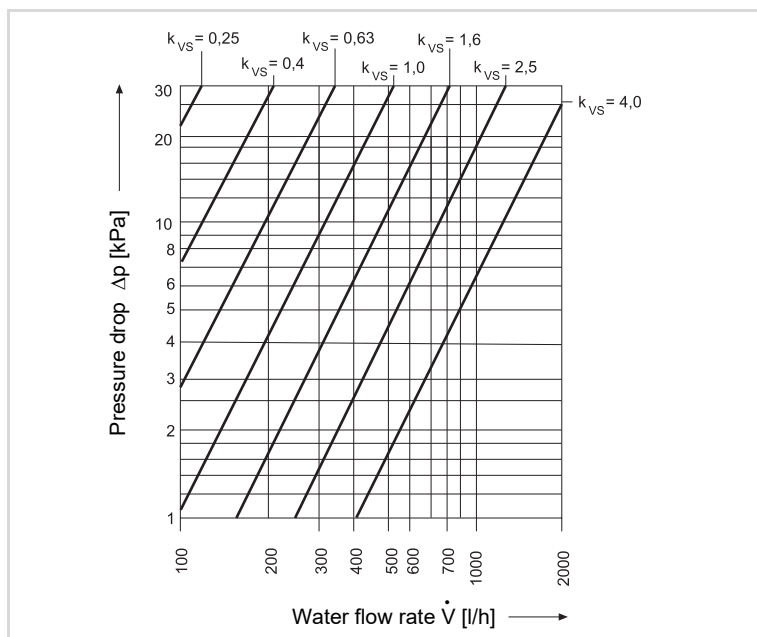

Fig. 90

Two and three-way valves with a modulating motor drive for water-side regulation (3-point modulating operation). Connecting cable, plastic motor casing, valve body made of brass (G 1/2"A) or red brass (G 3/4"A), stainless steel spindle and cone.

Technical data	230 V~	24 V~
Rated pressure	16 bar	
Max. ambient temp.	60°C	
Max. water inlet temp.	110 °C	
Operating voltage	230 V~/50/60 Hz	24 V~/50/60 Hz
Power consumption	7 VA	0.7 VA
Protection class	IP 43	
Running time	120 s at 50 Hz 100 s at 60 Hz	150 s at 50 Hz 125 s at 60 Hz

Water with a max. 50% glycol rate is allowed.  
 Do not mount the actuator upside down!

Valve values		
$k_{vs}$ -value [m <sup>3</sup> /h]	$\Delta p_{max}$ [kPa]	Valve Exter. thread
0,25	1600 <sup>1)</sup> /800 <sup>2)</sup>	G 1/2" A
0,40	1600 <sup>1)</sup> /800 <sup>2)</sup>	G 1/2" A
0,63	1600 <sup>1)</sup> /800 <sup>2)</sup>	G 1/2" A
1,0	1200 <sup>1)</sup> /250 <sup>2)</sup>	G 1/2" A
1,6	1200 <sup>1)</sup> /250 <sup>2)</sup>	G 1/2" A
2,5	400 <sup>1)</sup> /100 <sup>2)</sup>	G 3/4" A
4,0	400 <sup>1)</sup> /100 <sup>2)</sup>	G 3/4" A

1) max. allowed pressure difference, at which the valve closes against pressure (for 2-way valves)  
 2) for 3-way valves

Control valve can ship loose with or without connected pipework.

**Order No.**

$k_{vs}$ -value	Separately supplied valves		Separately supplied valves with piping	
	Two-way	3-way	Two-way	3-way
<b>Operating voltage 230 V~</b>				
0,25	935.421	935.411	VGf.R203.0#	VGf.R303.0#
0,40	935.422	935.412	VGf.R204.0#	VGf.R304.0#
0,63	935.423	935.413	VGf.R206.0#	VGf.R306.0#
1,00	935.424	935.414	VGf.R210.0#	VGf.R310.0#
1,60	935.425	935.415	VGf.R216.0#	VGf.R316.0#
2,50	935.426	935.416	VGf.R225.0#	VGf.R325.0#
4,00	935.427	935.417	VGf.R240.0#	VGf.R340.0#
<b>Operating voltage 24 V~</b>				
0,25	935.441	935.431	VGf.N203.0#	VGf.N303.0#
0,40	935.442	935.432	VGf.N204.0#	VGf.N304.0#
0,63	935.443	935.433	VGf.N206.0#	VGf.N306.0#
1,00	935.444	935.434	VGf.N210.0#	VGf.N310.0#
1,60	935.445	935.435	VGf.N216.0#	VGf.N316.0#
2,50	935.446	935.436	VGf.N225.0#	VGf.N325.0#
4,00	935.447	935.437	VGf.N240.0#	VGf.N340.0#

With mounted valves for a 4-pipe system the order number must be specified with the designation for the actuator, valve body and the  $k_{vs}$  value of the heating valve, e.g. VGf.N316N310.0#. The symbol "#" is reserved for medium connection left (L) and right (R) (see Unit type code Page 103).

**Note:**

The max. pressure drop in heat exchanger with fully open valve must not exceed 25 kPa in cooling mode and 20 kPa in heating mode!

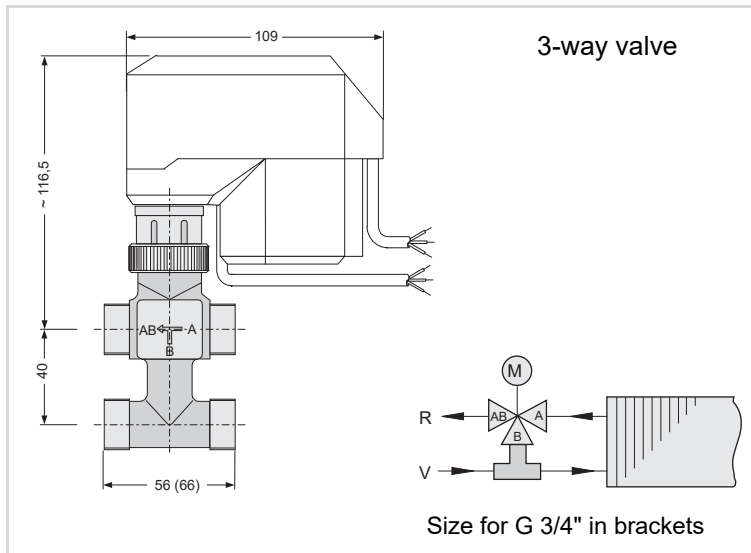

Fig. 91

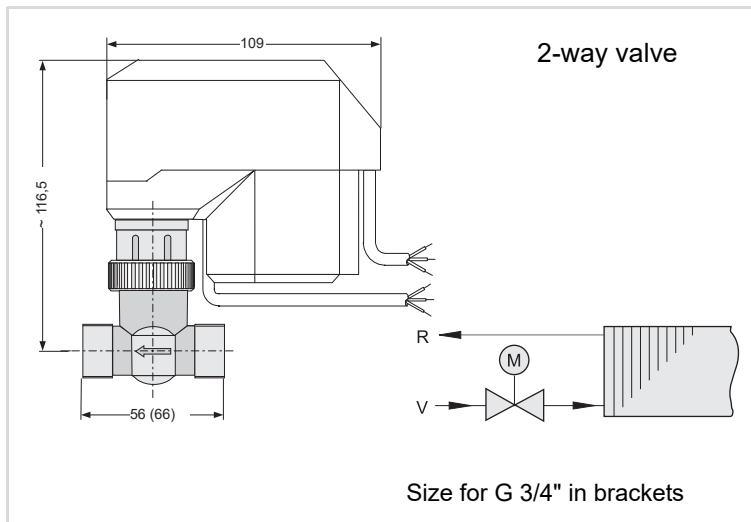

Fig. 92

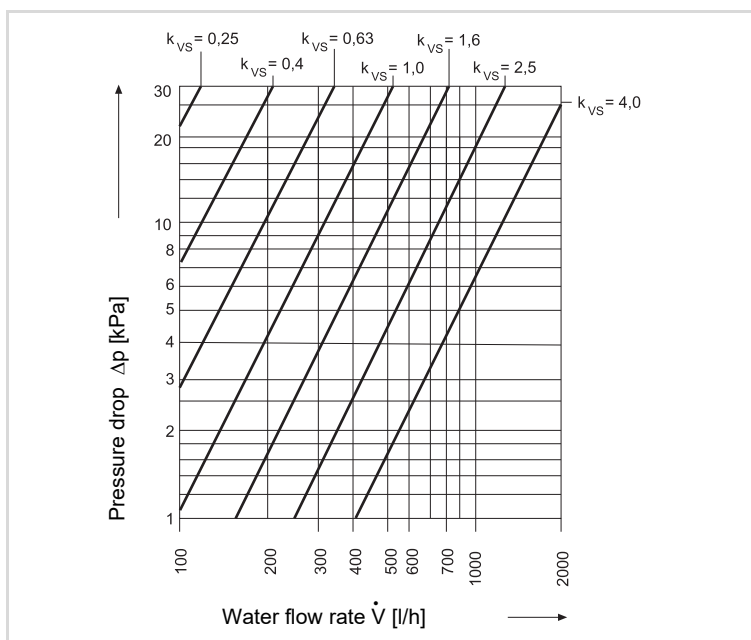

Fig. 93

Two and three-way valves with a modulating motor drive for water-side regulation (3-point modulating operation).

Connecting cable, plastic motor casing, brass valve body (G 1/2" A) or red brass (G 3/4" A), stainless steel spindle and cone.

Volt free auxiliary switch:

Switch S1 (valve message 100% open),

Switch S2 (valve position message 0 ... 100% adjustable)

Technical Data	
Rated pressure	16 bar
Max. allowed ambient temperature	60 °C
Max. water inlet temperature	110 °C
Operating voltage	230 V~ / 50/60 Hz
Power Input	7 VA
Protection class	IP 43
Running time	150 s at 50 Hz (125 s at 60 Hz)
Load capacity for auxiliary switch	max. 5(1) A/250 V max. 100 mA/24 V

Water with a max. 50% glycol rate is allowed.  
Do not mount the actuator upside down!

Valve values		
k <sub>vs</sub> -value [m <sup>3</sup> /h]	Δp <sub>max</sub> [kPa]	Valve Exter. thread
0.25	1600 <sup>1)</sup> /800 <sup>2)</sup>	G 1/2" A
0.40	1600 <sup>1)</sup> /800 <sup>2)</sup>	G 1/2" A
0.63	1600 <sup>1)</sup> /800 <sup>2)</sup>	G 1/2" A
1.00	1200 <sup>1)</sup> /250 <sup>2)</sup>	G 1/2" A
1.60	1200 <sup>1)</sup> /250 <sup>2)</sup>	G 1/2" A
2.50	400 <sup>1)</sup> /100 <sup>2)</sup>	G 3/4" A
4.00	400 <sup>1)</sup> /100 <sup>2)</sup>	G 3/4" A

1) max. allowed pressure difference, at which the valve closes against pressure (for 2-way valves)  
2) for 3-way valves

Control valve can ship loose with or without connected pipework.

**Order No.**

k <sub>vs</sub> -value	Separately supplied valves		Separately supplied valves with piping	
	Two-way	3-way	Two-way	3-way
0.25	935491	935481	VGF.C203.0#	VGF.C303.0#
0.40	935492	935482	VGF.C204.0#	VGF.C304.0#
0.63	935493	935483	VGF.C206.0#	VGF.C306.0#
1.00	935494	935484	VGF.C210.0#	VGF.C310.0#
1.60	935495	935485	VGF.C216.0#	VGF.C316.0#
2.50	935496	935486	VGF.C225.0#	VGF.C325.0#
4.00	935497	935487	VGF.C240.0#	VGF.C340.0#

With mounted valves for a 4-pipe system the order number must be specified with the designation for the actuator, valve body and the k<sub>vs</sub> value of the heating valve, e.g. VGF.C316C310.0#. The symbol "#" is reserved for medium connection left (L) and right (R) (see Unit type code Page 103).

**Note:** The max. pressure drop in heat exchanger with fully open valve should not exceed 25 kPa in cooling mode and 20 kPa in heating mode.

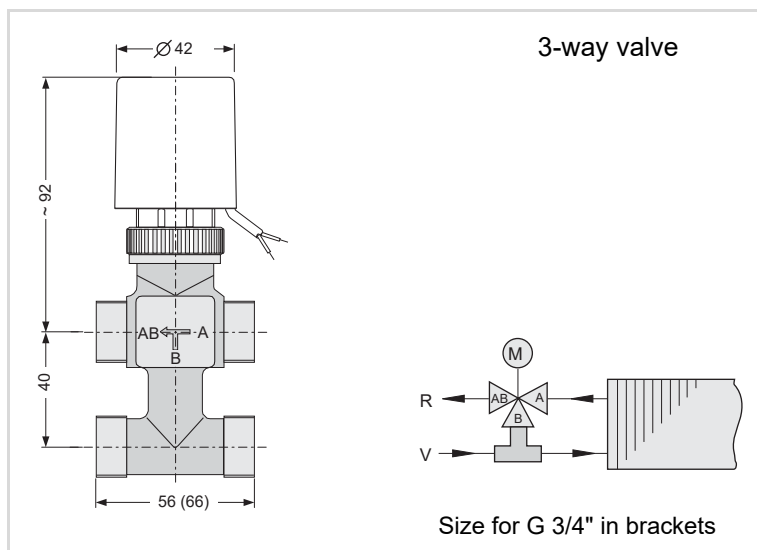

Fig. 94

Two and three-way valves with a thermoelectric actuators for water-side regulation (2-point modulating operation).

Connecting cable and plastic motor casing, brass valve body, stainless steel spindle and cone.

Technical Data	230 V~	24 V~
Rated pressure	16 bar	
Max. allowed ambient temperature	50 °C	
Max. water inlet temperature	110 °C	
Operating voltage	230 V~/50/60 Hz	24 V~/50/60 Hz
Starting current	0.3 A	0.6 A
Operating current	0.013 A	0.09 A
Power Input	3 VA	3 VA
Protection class	IP 43	
Running time	Approx. 3 min	

Water with a max. 50% glycol rate is allowed.  
Do not mount the actuator upside down!

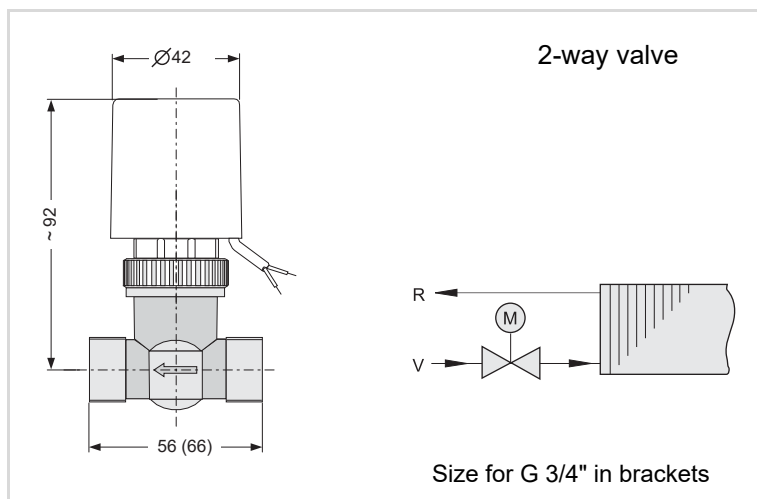

Fig. 95

Valve values		
$k_{vs}$ -value [m <sup>3</sup> /h]	$\Delta p_{max}$ [kPa]	Valve Exter. thread
1.60	200 <sup>1</sup> /150 <sup>2</sup> )	G 1/2"A
2.50	200 <sup>1</sup> /50 <sup>2</sup> )	G 3/4"A

1) max. allowed pressure difference, at which the valve closes against pressure (for 2-way valves)  
2) for 3-way valves

Control valve can ship loose with or without connected pipework.

**Order No.**

$k_{vs}$ -value	Separately supplied valves		Separately supplied valves with piping	
	Two-way	3-way	Two-way	3-way
<b>Operating voltage 230 V~</b>				
1.60	935463	935353	VGf.T216.0#	VGf.T316.0#
2.50	935464	935354	VGf.T225.0#	VGf.T325.0#
<b>Operating voltage 24 V~</b>				
1.60	935383	935373	VGf.Q216.0#	VGf.Q316.0#
2.50	935384	935374	VGf.Q225.0#	VGf.Q325.0#

With mounted valves for a 4-pipe system the order number must be specified with the designation for the actuator, valve body and the  $k_{vs}$  value of the heating valve, e.g. VGf.T316T325.0#. The symbol "#" is reserved for medium connection left (L) and right (R) (see Unit type code Page 103).

**Note:**

The max. pressure drop in heat exchanger with fully open valve should not exceed 25 kPa in cooling mode and 20 kPa in heating mode.

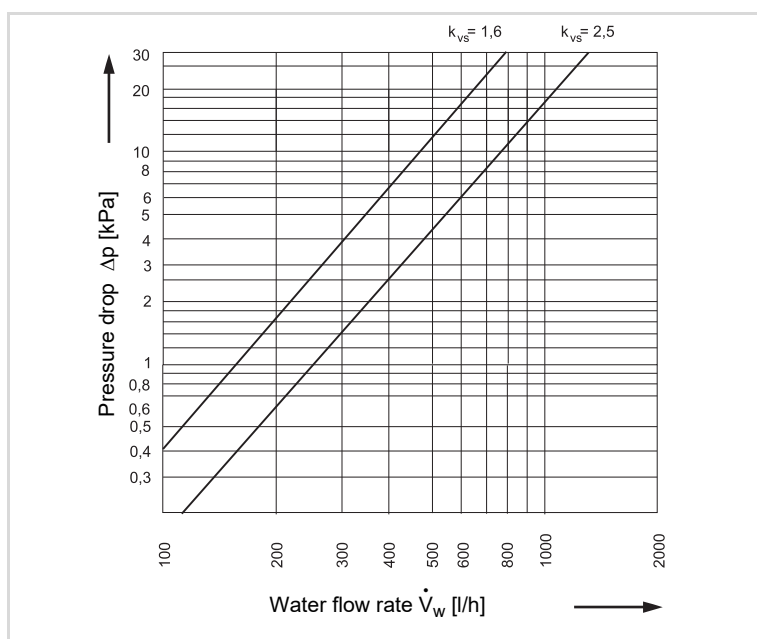

Fig. 96



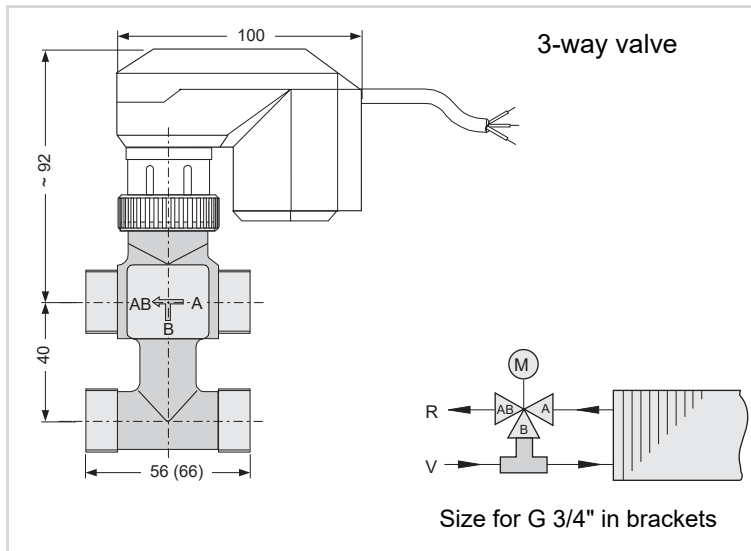

Fig. 97

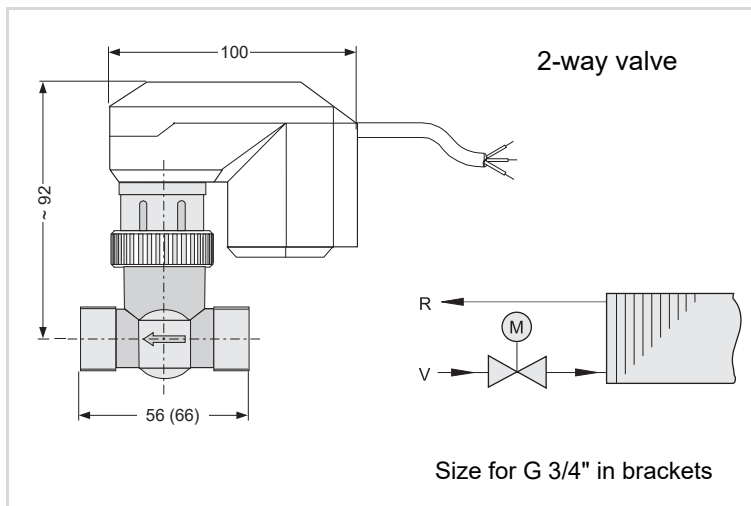

Fig. 98

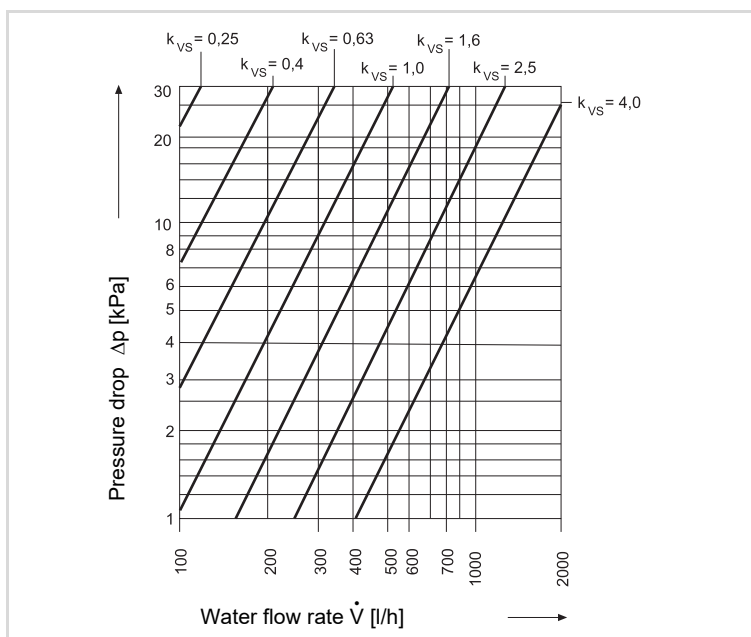

Fig. 99

Two and three-way valves with a continuous actuator for water-side regulation.

Connecting cable and plastic motor casing, brass valve body (G 1/2"A) or red brass (G 3/4"A), stainless steel spindle and cone.

Technical Data	
Rated pressure	16 bar
Max. allowed ambient temperature	55 °C
Max. water inlet temperature	110 °C
Operating voltage	24 V~/50/60 Hz
Analog control signal	0 ... 10 (2 ... 10) V
Power Input	1.4 VA
Protection class	IP 40
Running time	150 s at 50 Hz (125 s at 60 Hz)

Water with a max. 50% glycol rate is allowed.  
Do not mount the actuator upside down!

Valve values		
$k_{vs}$ -value [m <sup>3</sup> /h]	$\Delta p_{max}$ [kPa]	Valve Exter. thread
0.25	1600 <sup>1)</sup> /800 <sup>2)</sup>	G 1/2" A
0.40	1600 <sup>1)</sup> /800 <sup>2)</sup>	G 1/2" A
0.63	1600 <sup>1)</sup> /800 <sup>2)</sup>	G 1/2" A
1.00	1200 <sup>1)</sup> /250 <sup>2)</sup>	G 1/2" A
1.60	1200 <sup>1)</sup> /250 <sup>2)</sup>	G 1/2" A
2.50	400 <sup>1)</sup> /100 <sup>2)</sup>	G 3/4" A
4.00	400 <sup>1)</sup> /100 <sup>2)</sup>	G 3/4" A

1) max. allowed pressure difference, at which the valve closes against pressure (for 2-way valves)  
2) for 3-way valves

Control valve can ship loose with or without connected pipework.

**Order No.**

$k_{vs}$ -value	Separately supplied valves		Separately supplied valves with piping	
	Two-way	3-way	Two-way	3-way
0.25	935611	935601	VGf.S203.0#	VGf.S303.0#
0.40	935612	935602	VGf.S204.0#	VGf.S304.0#
0.63	935613	935603	VGf.S206.0#	VGf.S306.0#
1.00	935614	935604	VGf.S210.0#	VGf.S310.0#
1.60	935615	935605	VGf.S216.0#	VGf.S316.0#
2.50	935616	935606	VGf.S225.0#	VGf.S325.0#
4.00	935617	935607	VGf.S240.0#	VGf.S340.0#

With mounted valves for a 4-pipe system the order number must be specified with the designation for the actuator, valve body and the  $k_{vs}$  value of the heating valve, e.g. VGf.S316S310.0#. The symbol "#" is reserved for medium connection left (L) and right (R) (see Unit type code Page 103).

**Note:**

The max. pressure drop in heat exchanger with fully open valve should not exceed 25 kPa in cooling mode and 20 kPa in heating mode.

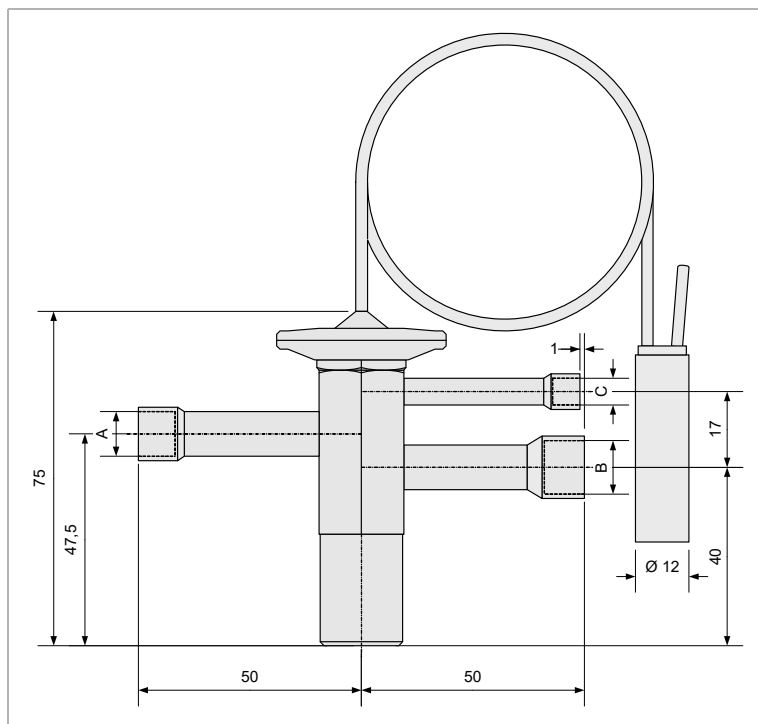

Fig. 100

Thermostatic expansion valve with external pressure equalization for best possible evaporator charging is especially designed for multiple injection through liquid distributor:

- variable capacity from 0.3 to 21.5 kW via exchangeable nozzle sets
- regardless of ambient temperature regulation of expansion valve is performed with high sensitivity for smallest possible overheating
- stable control performance through special adsorbing filling with attenuating features
- long service life thanks to welded stainless steel membrane
- adjustable superheating.

**Technical Data**

Refrigerant:	R410A
Max. test pressure:	32 bar
	(simultaneously for all connections)
Max. suction pressure:	29 bar
Max. ambient temperature:	100 °C
Max. sensor temperature:	140 °C
Static superheating:	approx. 3 K
Capillary tube length:	1.5 m
Casing/membrane head:	brass/stainless steel
Solder connections:	copper pipe

Depending on size of the basic unit thermostatic expansion valves are equipped with the following nozzle sizes and connections:

Model size	Nozzle size	Liquid connection	Suction gas connection	Pressure equalization line
		Sleeve	Sleeve	Sleeve
1	1.0	Ø 6 mm	Ø 12 mm	Ø 6 mm
2	1.5	Ø 10 mm	Ø 12 mm	Ø 6 mm
3	2.0	Ø 10 mm	Ø 12 mm	Ø 6 mm
4	2.0	Ø 10 mm	Ø 12 mm	Ø 6 mm
5	2.5	Ø 10 mm	Ø 12 mm	Ø 6 mm
6	2.5	Ø 10 mm	Ø 12 mm	Ø 6 mm
7	3.0	Ø 10 mm	Ø 12 mm	Ø 6 mm
8	3.0	Ø 10 mm	Ø 12 mm	Ø 6 mm

**Attention!**

In general, thermostatic expansion valves are designed for operation below 0 °C of evaporation temperature. Due to safety reasons and in order to prevent condensation on non-insulated components of basic casing, the operation with evaporation temperatures < 2 °C is not allowed.

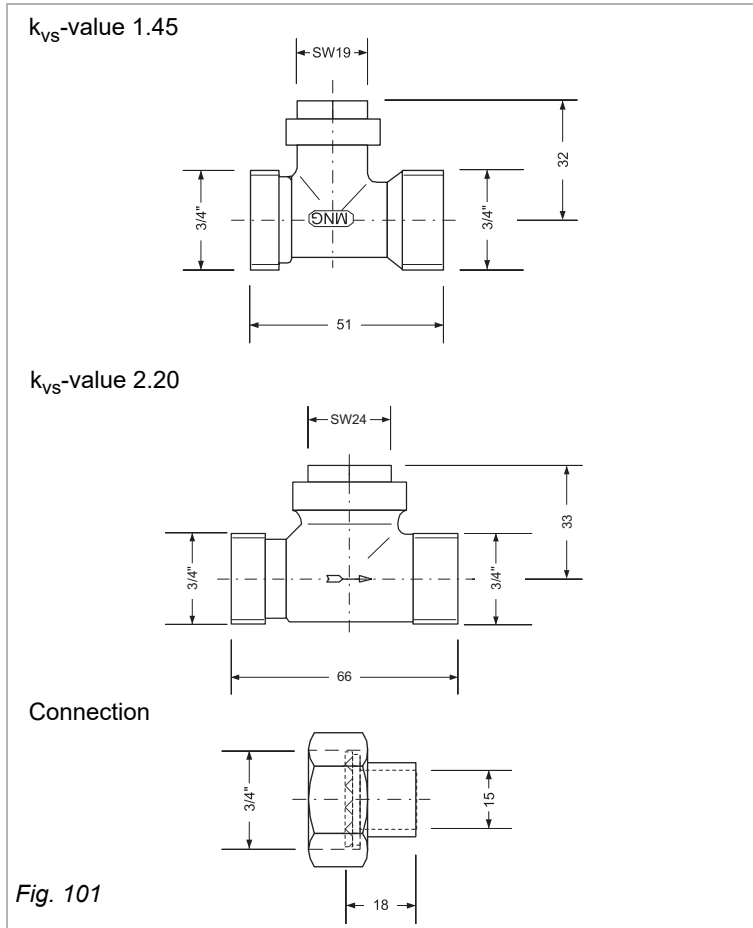

All valves, except the thermostatic expansion valves, can be optionally supplied with shut off valves at the return line.

These valves are used for shutting off the cooling or heating medium as well as for adjusting and equalizing medium flow rate.

Depending on rated size of the control valve, shut-off valves are used with k<sub>VS</sub>-value of 1.45 or k<sub>VS</sub>-value 2.20.

**Technical Data:**

Rated pressure: 10 bar  
 Max. water inlet temperature: 130 °C  
 pH-value: 8 - 9.5  
 As medium - water with a max. 50% glycol rate is allowed.

Depending on the fitted valves, the shut-off valves are supplied with outer thread connection (designation number „4“, see unit type code Page 103) or with connecting nut and solder fitting (designation number „5“, refer to unit type code Page 103):

Control valve		Shut-off valve		
k <sub>VS</sub> -values	Connection thread	k <sub>VS</sub> -values	Connection thread	Solder fitting for Cu pipe
0.25-1,60	G 1/2" A	1.45	G 3/4" A	Ø 15
2.50-4,00	G 3/4" A	2.20	G 3/4" A	Ø 15

The setting of the necessary medium flow rate is carried out on the basis of the following diagrams. The pre-setting corresponds to the number of rotations to the left of the adjusting screw starting from the right stop position (valve closed).

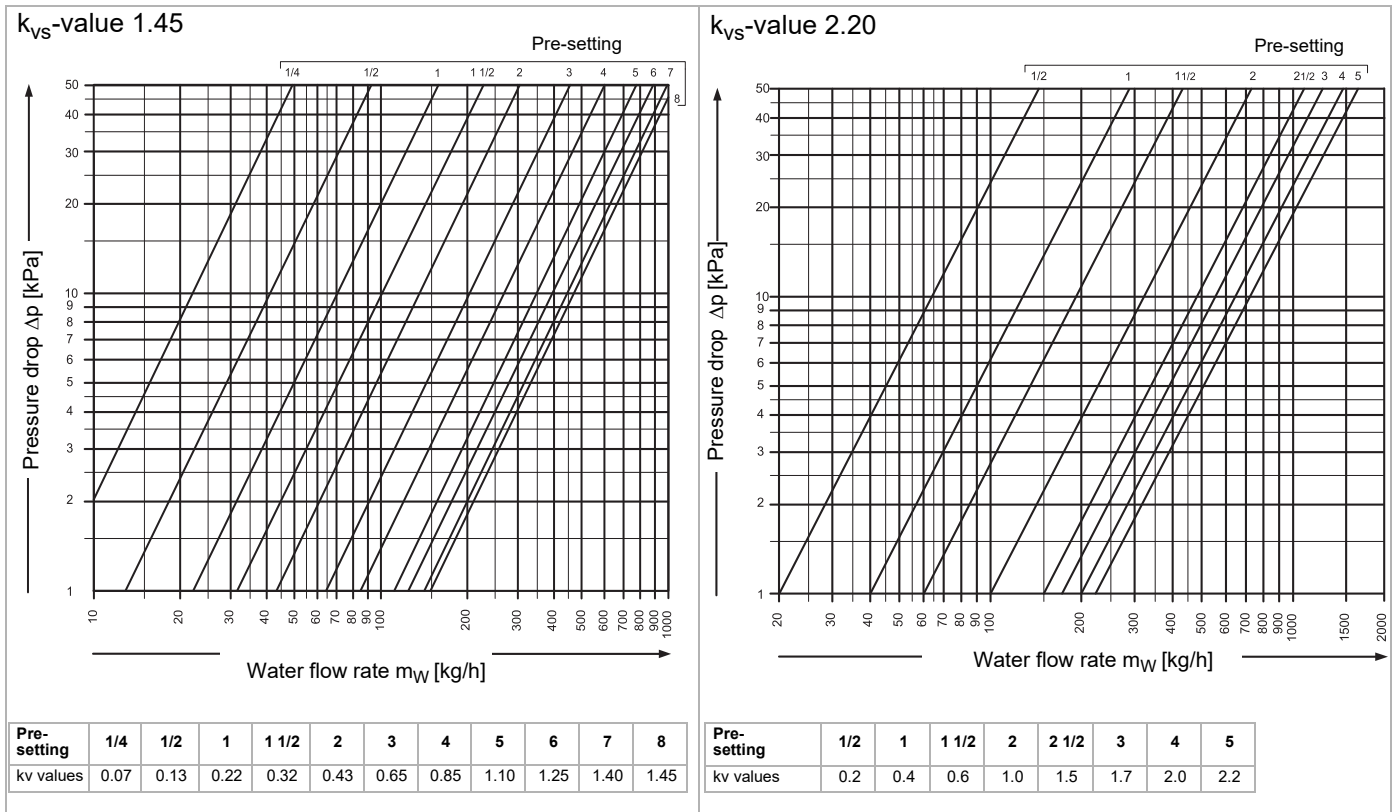

**Fig. 102**

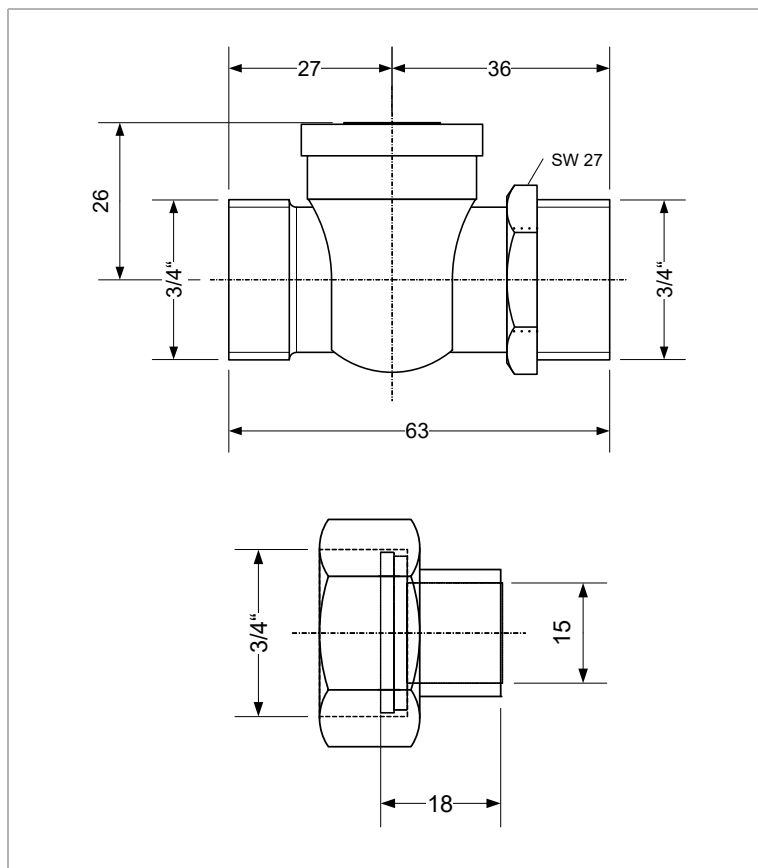

All valves, except thermostatic expansion valves, can be optionally supplied with ball cocks.

These are necessary to shut off cooling or heating medium.

**Material:**  
 Valve body: brass  
 Ball: brass, ground  
 Gasket: rubber

**Technical data:**  
 Rated pressure: 10 bar  
 Max. water inlet temperature: 110 °C  
 $k_{VS}$ -value: 6.70 m<sup>3</sup>/h

Water and water/glycol are allowed as medium.

Depending on the fitted valves, ball cocks are supplied with outer thread connection (designations 2 and 4, see Unit type code Page 103) or with connecting nut and solder fitting (designations 3 and 5, see Unit type code Page 103).

Ball valve		
$k_{VS}$ values	Connection thread	Solder fitting for Cu pipe
6.70	G 3/4" A	Ø 15

Fig. 103

The servicing of the ball cock is performed via a flat-bladed screwdriver.

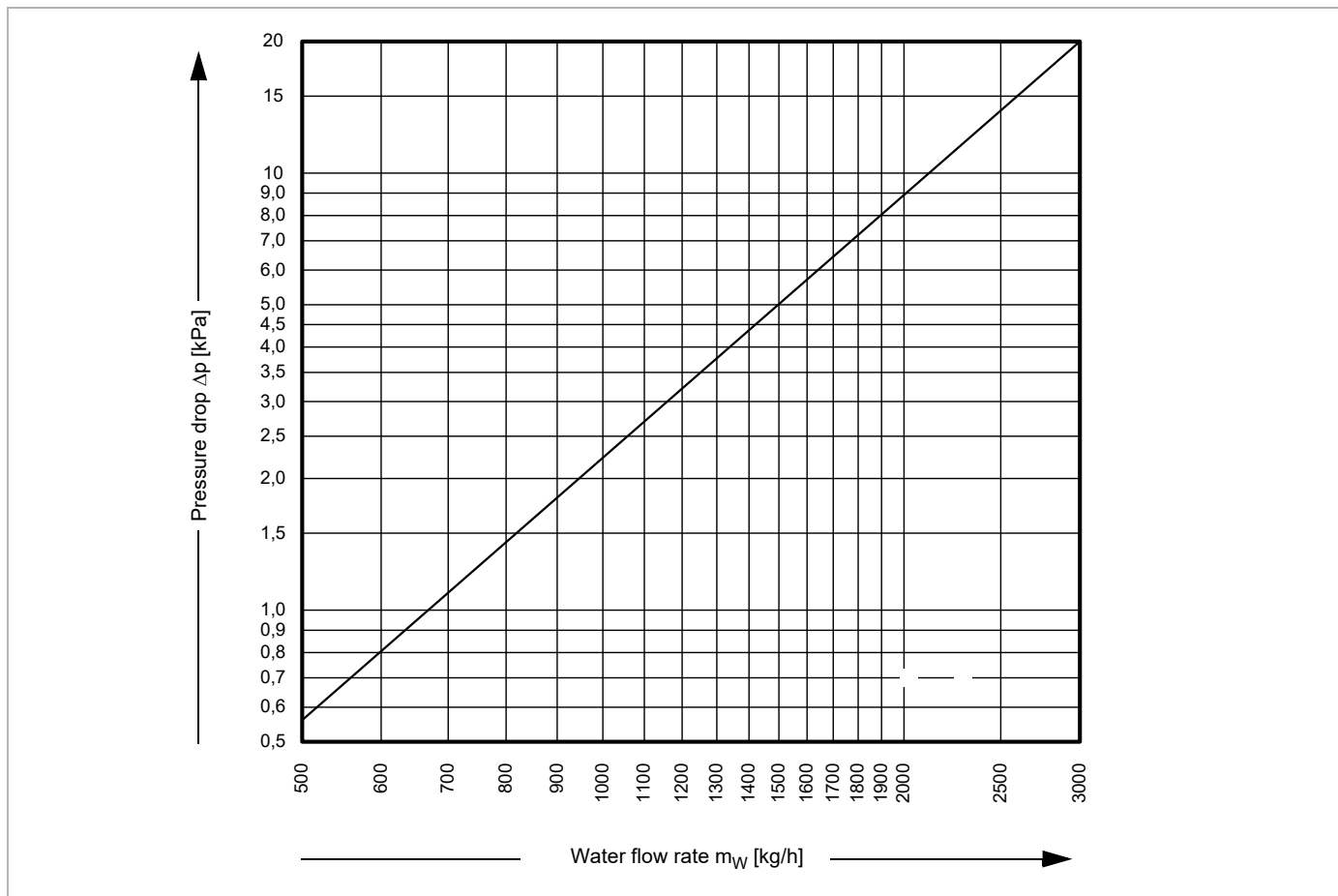



Fig. 104

**Terminal box with connections for fan coil units**







	Order code basic unit
<b>Terminal box</b> 	GFxx.xxxx.Axx
	GFxx.xxxx.Bxx
	GFxx.xxxx.Cxx
	GFxx.xxxx.Exx
	GFxx.xxxx.Hxx
<b>Metal sheet electric control box</b> 	GFxx.xxxx.Kxx
	GFxx.xxxx.Lxx
	GFxx.xxxx.Mxx
	GFxx.xxxx.Oxx
	GFxx.xxxx.Rxx

In order to carry out connection to the control system all components such as fan(s) and valve(s) are wired in the terminal box.

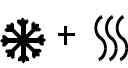
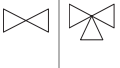
Depending on the selected unit configuration and valve equipment, the terminal box is either made of plastic or sheet steel. The selection is performed using the unit type code, as illustrated.

The following table illustrates possible variants.

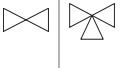
**Using thermostat and miniature switches of series C standard control is provided for fan coil units.**

The switches can be used with:			Valve type	Switch type	Return-air sensor		Order code		Possible install.	
					w/o	with	EC motor	AC motor		
	Cooling and Heating		4-pipe system chilled and warm water		CMT4D (fan continuous mode)	0	-	-	2	A
					CET.ACEC	0	5	-	J	A, B
	Cooling or Heating		2-pipe system chilled or warm water		CMT2Z (fan and valve control) order contact temperature thermostat separately (using order number 902 135)	0	-	-	4	A
					CMT2D (fan continuous mode) order contact temperature thermostat separately using order number 902 135	0	-	-	3	A
					CET.ACEC with flow sensor (flow sensor included in the package)	1	6	-	J	A, B
	Heating		2-pipe system warm water		CMT2Z (fan and valve control)	0	-	-	4	A
					CMT2D (continuous fan mode)	0	-	-	3	A
					CET.ACEC	0	5	-	J	A, B
	Cooling		2-pipe system chilled water		CMS	0	-	-	1	A, B
					CMT2Z (fan and valve control)	0	-	-	4	A
CMT2D (continuous fan mode)					0	-	-	3	A	
CET					0	5	-	J	A, B	
				CMS	0	-	-	1	A, B	

Alternatively to a return air sensor, a room temperature sensor can also be connected to a CET type switch. If a return air sensor is used, the fan must be operating continuously.

**Please consider:**

In connection with thermostat / miniature switches only 2-point open/close valve actuators can be used (T). If a CET.ACEC switch is installed, a return air sensor or room temperature sensor must be connected!

**Relay kit**  
is necessary if a maximum four fan coil units with AC motors are switched in parallel. Mixing of different FCU types and sizes is allowed. The CET.ACEC relay kit is absolutely required using model size 8 in connection with the switch.

With kit	2
Without kit	0

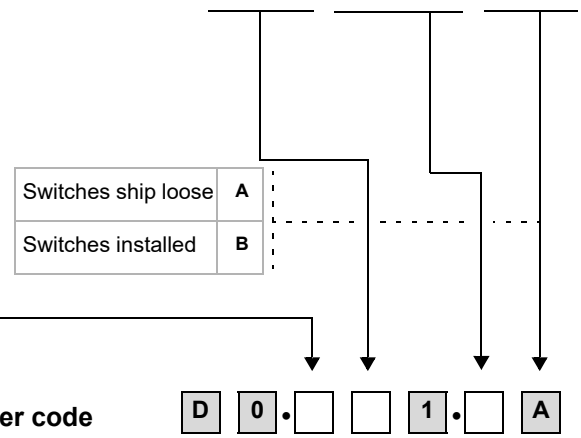



**Slave unit with relay kit**





Order code **D 0 . 2 0 1 . Z D**



**NOTICE!**  
If you want to use several units with an AC motor with one switch you will need a relay kit for each unit. For units with cooling function we recommend fan continuous operation (fin drying)

## Operation of thermostat and speed switches

Switch type		Functions
CMS		<ul style="list-style-type: none"> <li>– On/off switch</li> <li>– Fan speed selection switch 1-2-3</li> <li>– Plastic casing: white, similar to RAL 9016</li> <li>– Control elements: grey, similar to RAL 7044</li> <li>– Protection class IP 30</li> </ul>
CMT		<ul style="list-style-type: none"> <li>– On/off switch</li> <li>– Fan speed selection switch 1-2-3</li> <li>– Setpoint setting room temperature 10..30 °C (mechanical setting range limitation as accessory on request)</li> <li>– Thermostat with neutral zone (only CMT4D)</li> <li>– Plastic casing: white, similar to RAL 9016</li> <li>– Control elements: grey, similar to RAL 7044</li> <li>– Protection class IP 30</li> </ul>
CET.ACEC		<ul style="list-style-type: none"> <li>– Fan speed selection switch standby auto 1-2-3</li> <li>– AC or EC fan control</li> <li>– External valve control possible (e.g. floor heating, chilled ceiling)</li> <li>– Setpoint setting for room temperature 10..30 °C (adjustable setting range limitation)</li> <li>– Thermostat with settable neutral zone</li> <li>– Input for unit enabling via volt free dry contact by others</li> <li>– Room frost protection, connection possibilities for external room or return-air sensor and flow sensor</li> <li>– Integrated room temperature sensor</li> <li>– Interface MODbus RS485 RTU</li> <li>– Factory pre-configured</li> <li>– Plastic casing: white, similar to RAL 9016</li> <li>– Protection class IP 30</li> </ul>

Sensors		Functions
Room temperature sensor 903 414		Thermistor sensor for on-wall mounting <ul style="list-style-type: none"> <li>– NTC-sensor element; resistance coefficient at 25 °C = 10 kΩ</li> <li>– Plastic casing: white, similar to RAL 9010</li> <li>– Protection class IP 20</li> <li>– Dimensions in mm (W x H x D): 84 x 84 x 22</li> </ul>
Flow sensor 903 435		Thermistor sensor for mounting at inlet with clip <ul style="list-style-type: none"> <li>– NTC-sensor element; resistance coefficient at 25 °C = 10 kΩ</li> <li>– Sensor dimensions (D x L): 6.25 x 27 mm; cable length 2.5 m</li> <li>– Max. ambient temperature 100 °C</li> </ul>
Return-air sensor 903 475		Thermistor sensor for mounting in unit <ul style="list-style-type: none"> <li>– NTC-sensor element; resistance coefficient at 25 °C = 10 kΩ</li> <li>– Sensor dimensions (D x L): 6.25 x 27 mm; cable length 2.5 m</li> <li>– Max. ambient temperature 60 °C</li> </ul>
Contact thermostat 902 135		Contact temperature thermostat for change-over between heating or cooling mode <ul style="list-style-type: none"> <li>– For mounting on pipework with diameter from 15 mm to 28 mm</li> <li>– Operating voltage 250 VAC 50/60 Hz</li> <li>– Dimensions in mm (W x H x D): 79 x 50 x 44</li> </ul>

Additional sensors which are supplied loose and wired on-site by others should be ordered optionally (not in connection with the above-mentioned switch types CMT and CMS).

**NOTICE!**

Flow and return air sensor are integrated in the relevant controls packages and do not have to be selected separately if ordered using the package number.

Overview

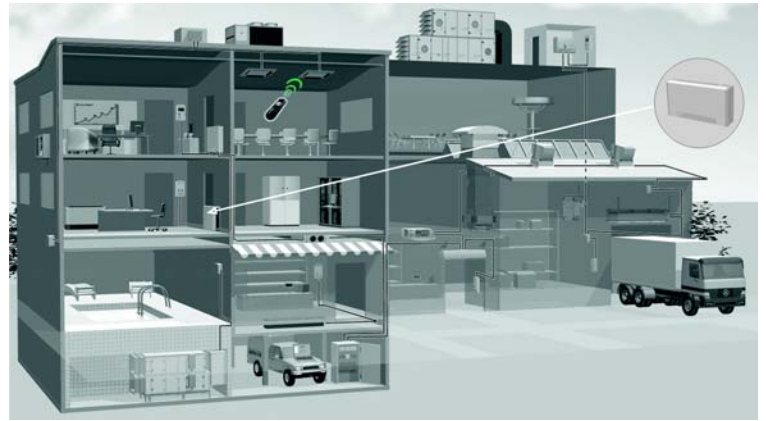

		Valve actuator type	
		2 point (modulating)	3 point (modulating)
		•	
		•	•
		•	•
		•	•

**MATRIX 2000**

MATRIX 2000 control system supports all basic functions (heating/cooling) of recirculating-air fan coil unit and can be used in the following unit types:

- 2-pipe units „only heating“
- 2-pipe units „only cooling“
- 2-pipe units „cooling or heating“ (change over)
- 4-pipe unit „cooling and heating“

The assignment of speed stage can be carried out manually in a 3-speed mode or automatically in a 3-speed mode based on the deviation of actual temperature from the setpoint. Valves with on/off or 2-point modulating control behavior and a supply voltage of 230 V AC can be activated to control the heating and/or cooling capacity. With 2-pipe units 3-point modulating valve actuators can alternatively be controlled as well. The operation of 24 V AC valve actuators is possible as well (transformer by others required).

The direct connection of an external room temperature sensor is not possible with changeover units, but can be performed via a Global Module. An alarm signal can also be processed by a Global module. Direct tapping is not possible.

Additionally, the MATRIX 2000 enables monitoring of the fan motor via thermal contacts with external leads as well as the condensate water level for cooling units with a condensate pump. An alarm signal can also be processed by a Global module. Direct tapping via floating contacts is not possible. The connected sensors are monitored as well.

The OP2000 control panel enables the setpoint values to be set quickly and easily without extensive prior experience. Mechanical limit stops can be used to limit the setting range for the setpoint temperature and speed stage. Room temperature is measured via a sensor integrated in the control panel. If the control panel is positioned in an unfavorable location (such as by the door), an external temperature sensor or return air sensor can be connected (not possible on changeover systems). System faults are signaled centrally via the red “malfunction” LED and output using a changeover contact. If economy mode is activated, it is displayed via the yellow LED integrated into the button.



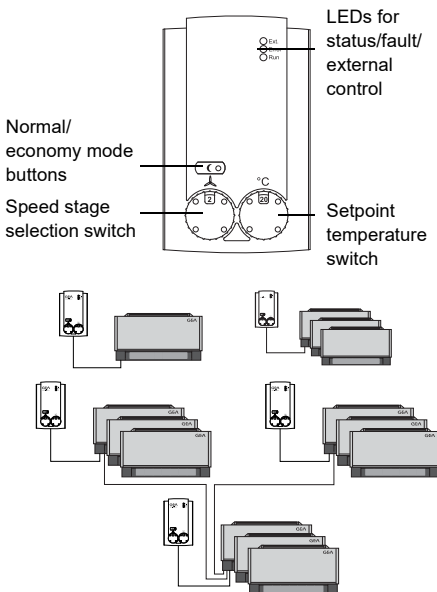

In addition to protection class IP20 (OP21 C), an OP21 I control panel in protection class IP54 for moist areas can be used.

The connection in the unit is made via plug-in cage clamps. Electronics, fans and valves (230V) are fused separately via two pre-fuses on the power supply. A fuse of B 10A type must be supplied to provide the necessary circuit protection.

The MATRIX 2000 can be used for controlling individual recirculating-air units and recirculating-air unit groups as well. The integrated MATRIX.Net bus system enables integration of up to 16 several groups to one network. The combination with MATRIX 3000 controllers and connection of Global Modules and communication interfaces is also possible.



System Description

		Valve actuator	
		2 point	3 point
		•	•
		•	•
		•	•
		•	•

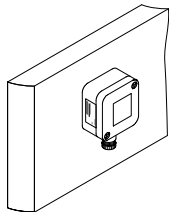
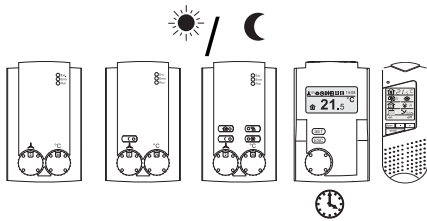
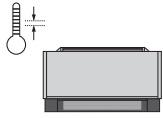

**MATRIX 3000**

The MATRIX 3000 control system is based on the MATRIX 2000 system and provides the following additional functions. These features are described as follows: 3-point valves with modulating control behavior can be applied on 4-pipe systems. Mixed operation is also possible (2-point cooling valve / 3-point modulating heating valve or 3-point modulating cooling valve / 2-point heating valve).

Status and alarm signals are relayed via two change-over contacts on the unit. The maximum load on the contacts at 230 V AC is 4 A ohmic / 2 A inductive.

The supply air temperature can be limited for heating and cooling. Fixed and sliding limits can be defined.

An external temperature sensor or return air sensor can be connected to all system types.

An additional control input enables the following operating modes that can be set externally:

- Normal/economy operation **or**
- Unit OFF with frost protection

Various types of control panels are available. The range varies from a simple variant with setpoint temperature and fan operating mode selection using infrared remote control to a control panel with display. The display unit can also be supplied with an integrated weekly timer.

**MATRIX 4000**

The MATRIX 4000 control system is based on the MATRIX 2000/3000 system and provides the following additional functions. These features are described as follows:

In order to provide enhanced selection of heating/cooling duty - a five speed and continuous (EC) fan motor control is enabled.

For applications with highest comfort requirements electronic control elements provide absolutely silent valve control.

Four additional control inputs enable external assignment of the following operating modes:

- Normal operation
- Economy mode
- Free mode
- Unit OFF with frost protection
- Compulsory setting of a fan speed

It is also possible to connect the outdoor sensor for activation of summer compensation. Outdoor air temperature reading is automatically transmitted to all units connected within the MATRIX.Net.



Performance characteristics		MATRIX 2000	MATRIX 3000	MATRIX 4000
Unit type	2-pipe systems: „only heating“, „only cooling“; „heating or cooling“	✓	✓	✓
	4-pipe system heating and cooling	✓	✓	✓
Fan	up to 3 speeds	✓	✓	✓
	up to 5 speeds			✓
	continuous (EC motor)		✓	✓
	Temperature related fan speed switching	✓	✓	✓
	Minimum speed 1	✓	✓	✓
	Motor monitoring with external thermal contacts	✓	✓	✓
Valve control	2 and 4-pipe system: on/off actuators	✓	✓	✓
	2-pipe system: 3-point modulating actuator	✓	✓	✓
	4-pipe system: 3-point modulating actuators		✓	✓
	Silent control (semiconductor relay)			✓
	External heating valve with cooling unit with fan switch off	✓	✓	✓
Electric heater	1-speed	✓	✓	✓
	2-speed			✓
Frost protection	Indoor Anti-Freeze Protection	✓	✓	✓
	Unit anti-freeze protection			✓
Summer/winter compensation		✓*	✓*	✓
Supply temperature limitation	Min/Max limitation heating		✓	✓
	Min/Max limitation cooling		✓	✓
Control inputs	Economy mode or door or window contact	✓*	✓	✓
	Economy mode and door or window contact and unit OFF and autonomous operating mode	✓*	✓*	✓
Measuring outside temperature	via local sensor connection			✓
	using MATRIX.AI	✓	✓	✓
Measuring inlet temperature	via local sensor connection	✓	✓	✓
Measuring return air temperature	via local sensor connection	✓**	✓	✓
Measuring supply air temperature	via local sensor connection		✓	✓
Messages/signals	Alarm condensate level too high with unit switch off	✓	✓	✓
	Heating and/or cooling request	✓*	✓*	✓
	Status signal via change-over contact	✓*	✓	✓
	Fault signal via change-over contact	✓*	✓	✓
Mixing-air damper control	Open/close or continuous			✓
Exhaust fan control	1 speed via relay output			✓
	via power unit / exhaust air controller			✓
Chiller control	up to 2 speeds via MATRIX.RF module		✓	✓
Control modes	Room temperature control	✓	✓	✓
	Supply Air Temperature Control		✓	✓
MATRIX.Net bus system		✓	✓	✓
Geko-Drive	continuous via add-on module MATRIX Geko-Drive			✓*
can be extended by:	MATRIX.DI	✓	✓	✓
	MATRIX.AI	✓	✓	✓
	MATRIX.DO	✓	✓	✓
	MATRIX.RF		✓	✓
	MATRIX.EM			✓
	MATRIX.LON	✓	✓	✓
Service tool	MATRIX.PC	✓	✓	✓
Control panels	MATRIX OP21x	✓		
	MATRIX OP30x		✓	✓
	MATRIX OP31x		✓	✓
	MATRIX OP44x		✓	✓
	MATRIX OP50x/51x		✓	✓

\* only with add-on module

\*\* not with heating or cooling units

## Mounting control panels

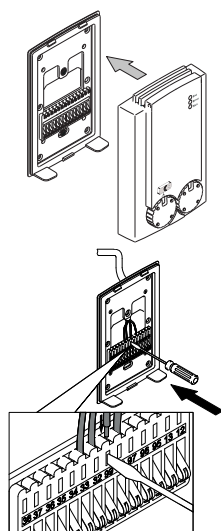

As the control panel is divided in two parts, its cover should only be snapped on the mounting plate for commissioning. This provides optimum protection against dirt and damage for the control panels during the construction phase.

The cable connection is established via cage clamps. This enables quick and easy use of solid and flexible cores.

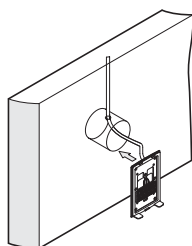

To mount the control panel in a standard flush-mounted socket, corresponding drill holes need to be provided in the mounting plate.

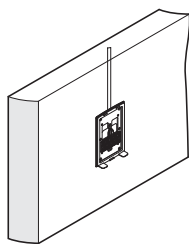

The control panel can also be fitted directly on the wall (cable laid under plaster or in cavity wall).



Control panel can be mounted on the basic unit using the ZE OPC installation kit. For this case an external room or return temperature sensor must be provided.

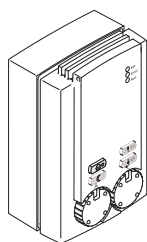

IP54 control panels for moisture proof applications are available on request.

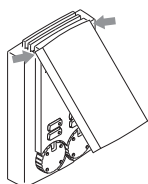

To prevent dirt accumulation or accidental operation, control panel covers are available as accessory items.



Fig. 105

### Room temperature sensor order Nr. 903.414

Thermistor sensor for on-wall mounting

- NTC sensor element
- Plastic casing: white, similar to RAL 9010
- Resistance coefficient at 25 °C = 10 kΩ
- IP 20 class
- Dimensions in mm (W x H x D): 84 x 84 x 22

The room temperature sensor 903.414 replaces the room temperature sensor in the MATRIX OP XXC control panels. The additional sensor must be fitted if the control panel is integrated in the FCU or mounted in a location that is unsuitable for accurate temperature measurement.



Fig. 106

### External sensor order-Nr. 903.454

Thermistor sensor for measuring ambient temperature e.g. for summer/winter compensation (according to DIN 1946 part 2/3)

- NTC sensor element
- Impact resistant white plastic casing
- for outdoor wall mounting
- PG bolts
- Resistance coefficient at 25 °C = 10 kΩ
- IP 54 class
- Dimensions in mm (W x H x D): 65 x 50 x 37.5



Fig. 107

### Unit cap

White order nr.OPD.C  
(for OP21C/OP30C/OP31C/OP44C)

Light grey order-nr.OPD.I  
(for OP21I/OP30I/OP31I/OP44I)

For covering operating elements of control panel

The control panel cover is hung into the guide slots of the control panel and protects the control panel from dirt accumulation and accidental operation.

## Global Modules

The global modules of the MATRIX control system are designated for input and output of MATRIX system signals. Global modules enable the transmission of messages and unit status information to external units as well as control via such external units. The modules can be integrated anywhere within the MATRIX network. A network can contain and simultaneously operate a maximum of 2 MATRIX modules of the same type (DI,DO,AI) or 16 modules (LON).

The modules are supplied with the default factory configuration. Configurations with other settings can be performed using the MATRIX.PC software.

### Technical Data

Power supply	24 V DC ± 15 %
Protection class	IP 20
Operating temperature	0 to +45 °C
Fusing	10 A T
Fixation	Mounting rail
MATRIX.DI max. current consumption	0.1 A
MATRIX.DI dimensions	106 mm x 90 mm x 58 mm
MATRIX.DO max. current consumption	0.14 A
MATRIX.DO contact load	250 V/5 A (ohmic); 2 A (inductive)
MATRIX.DO dimensions	160 mm x 90 mm x 58 mm
MATRIX.AI rated current consumption	0.03 A
MATRIX.AI dimensions	160 mm x 90 mm x 58 mm
MATRIX.LON rated current consumption	0.045 A
MATRIX.LON dimensions	106 mm x 90 mm x 58 mm

### Digital input module MATRIX.DI

The digital input module MATRIX.DI is used to receive 8 independent digital control signals.

Factory configuration:

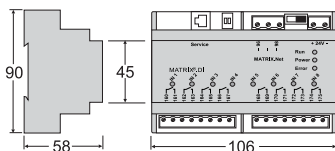

Input	Valid for	Closed contact results in
1	All groups	Operation Mode Heating
2	All groups	Operation Mode Cooling
3	All groups	normal operation
4	All groups	Economy mode
5	Group 0	Fan in speed 3
6	Group 0	Secondary-air louvre close
7	Group 0	Secondary-air louvre open
8	Group 0	100 % mixed-air operation

### Digital output module MATRIX.DO

The module is fitted with 8 separate digital outputs with volt-free changeover contacts.

Factory configuration:

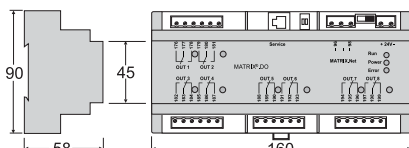

Output	Valid for	Relay on signals
1	All groups	Operating principle
2	Group 0	Fault signal
3	Group 0	Frost alarm
4	Group 1	Fault signal
5	Group 1	Frost alarm
6	Group 2	Fault signal
7	Group 2	Frost alarm
8	All groups	Fault signal

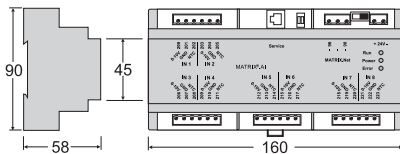

### Analog input module MATRIX.AI

The module is equipped with 8 independent analog inputs that are controlled using 0...10 V/2..10 V signals or can be fitted with NTC sensors (10 k Ohm/25 °C).

Factory configuration:

Eingang	valid for	Parameter	Art	Filter value	Measured range
1	All groups	Outdoor temperature	NTC	0	–
2	All groups	Inlet temperature	NTC	0	–
3	Group 0	Room set point	0 ... 10 V	0	10 – 30 °C
4	Group 1	Room set point	0 ... 10 V	0	10 – 30 °C
5	Group 2	Room set point	0 ... 10 V	0	10 – 30 °C
6	Group 1	Outdoor-air rate	0 ... 10 V	0	0 ... 100 %
7	Group 2	Outdoor-air rate	0 ... 10 V	0	0 ... 100 %
8	Group 3	Outdoor-air rate	0 ... 10 V	0	0 ... 100 %

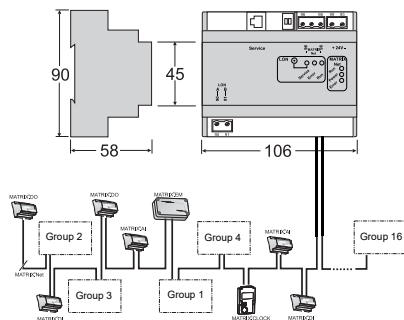

### MATRIX.LON module

The MATRIX.LON communication module is part of the global modules of the MATRIX control system and is used for connecting the MATRIX control system to a network structure in accordance with the LON WORKS standard. It enables the connection of HVAC equipment to a building management system or other facility management systems. The modules also enables external systems such as dampers/louvres or lighting systems to be regulated via the MATRIX OP50/51 control panel. The module can be integrated at any point within the MATRIX network.

### Service software MATRIX.PC

MATRIX.PC service software provides further comprehensive functions for settings, commissioning and data recording of the MATRIX controller system. The service software can be connected via the service interface which is integrated in all control panels, controllers, global modules, clock timer and communication modules. Your PC must have a USB port; the enclosed adapter establishes the connection between the PC and the service interface. The following main functions are available:

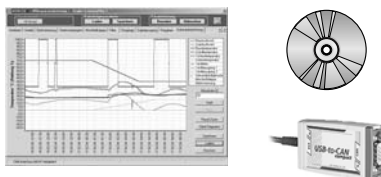

- Automatic scanning of network with display of found users
- Display of errors as text
- Changing parameters as e.g. temperature limits, times or control mode
- Display of actual values
- Display of current unit status, e.g. Operation Mode or valve position
- Manual control of actuators for fans and valves
- Reading, saving and writing configuration data
- Online display of module, status and network data
- Recording and saving of temperature curves and switch states of driven components with adjustable sample rate
- Offline settings
- Programming of required inputs and outputs (controllers, global modules)
- Activation of messaging and network data
- Configuration of controller and control panel functions
- Input of sensor correction factors
- Selection of 6 different languages

PC system requirements:

- PC with 233 MHz processor frequency or higher
- 20 MB available disk space
- Minimum monitor resolution of 800 x 600 pixels
- USB interface for CAN adaptor

The software is compatible with the following operating systems:

Windows 98 Second Edition; Windows 2000; Windows XP

Together with main software on a CD, the installation instructions and interface module for connection to the PC USB port are also included.

## MATRIX.OP71 control panel for all groups



The MATRIX.OP71 control panel is designed for operation from one central point. This control panel can be integrated at any location within the MATRIX network and can be simultaneously operated in 16 groups.

Up to 16 unit groups can be assigned to one cluster:

- One unit group per each cluster
- Each cluster to include up to 16 unit groups.

Clear text menus and "push&turn" function enable easy handling during operation or configuration. A maximum of 16 unit groups can be individually grouped to clusters. Using a control panel the desired setpoints for temperature, fan speed, etc. can be assigned for each cluster. Thanks to comprehensive features of the control panel, the necessary room or return air sensors are located in the respective groups (group locations).

Local control panels (OP2xx, OP3xx, OP4xx, OP5x) can be additionally integrated in individual groups. Their functional scope can be defined and adjusted using the control panel for all groups. Thus, a relative daily setpoint can be entered via a local control panel, whereas the standard setpoint is assigned via the OP71C.

The integrated clock timer enables to assign 8 weekly programmes to clusters at any sequence. Each weekly programme enables to enter four switching times per day (2 x On/2 x Off), that can also be set to be valid for the whole day. In addition, it is possible to set 8 special switching days with up to four switching times (2 x On/2 x Off) per designated switching day.

Holidays / bank holidays can be set using the calendar annual programme.

On holidays the unit can be set to operate in "unit off" or economy mode.

The summer / winter time changeover is performed automatically.

The control unit is currently supplied with 7 selectable languages:

- German
- English
- French
- Dutch
- Polish
- Czech
- Hungarian.

Two different variants are available:

- MATRIX.OP71C with IP20 protection type; colour – white (similar to RAL 9016)
- MATRIX.OP71I with IP54 protection type; colour – light grey (similar to RAL 7035).

Unit type code

G F 1 1 U 0 W 1 A 0 0 A 1

<b>Model size</b>	1 = Model size 1 2 = Model size 2 3 = Model size 3 4 = Model size 4 5 = Model size 5 6 = Model size 6 7 = Model size 7 8 = Model size 8
<b>Capacity stage</b>	1 = Capacity stage 1 2 = Capacity stage 2 3 = Capacity stage 3 4 = Capacity stage 4
<b>Aerodynamic function</b>	U = Recirculating-air unit M = Mixed-air unit
<b>Medium function</b>	Heating only 0W = PWW 0E = Electric full heating 0F = PWW + E-add-on heating Cooling only W0 = Chilled water pump D0 = Direct Expansion Cooling or heating WC = Pumped chilled - warm water WB = PCW - PWW + E-add-on heating Cooling and heating Warm water = Pumped chilled - warm water WE = PCW - Electric heater WF = PCW - PWW + E-add-on heating DW = Direct evaporator - PWW
<b>Coil connection *</b>	Wall 1 = Left 2 = Right Ceiling 3 = Left 4 = Right
<b>Speeds</b>	Terminal box A = Speed 1, 2, 3 B = Speed 2, 3, 4 C = Speed 3, 4, 5 E = Speed 1, 3, 5 H = Speed 1, 2, 3, 4, 5 F = Min..Max (EC motor) terminal box Metal sheet electric control box with terminal block or for controls K = Speed 1, 2, 3 L = Speed 2, 3, 4 M = Speed 3, 4, 5 O = Speed 1, 3, 5 R = Speed 1, 2, 3, 4, 5 S = Min..Max (EC motor) metal switch box with terminal block or for controls
<b>Motor/thermal contacts</b>	0 = Standard motor (ball bearings) with integ. therm. contact 1 = Standard motor (ball bearings) with external therm. contact E = EC motor (ball bearings)
<b>Condensate pump</b>	0 = with condensate drain 1 = with condensate pump
<b>Air flow **</b>	A = Circulating air: Circulating air ↗↖ - supply air ↗↖ Mixed air: Fresh air ↘↙ - circulating air ↗↖ - supply air ↗↖ B = Circulating air: Circulating air ↗↖ - supply air ↘↙ Mixed air: Fresh air ↘↙ - circulating air ↗↖ - supply air ↘↙ C = Circulating air: Circulating air ↗↖ - supply air ↗↖ Mixed air: Fresh air ↗↖ - circulating air ↗↖ - supply air ↗↖ D = Circulating air: Circulating air ↗↖ - supply air ↘↙ Mixed air: Fresh air ↗↖ - circulating air ↗↖ - supply air ↘↙
<b>Filter</b>	1 = G1 mat filter 2 = G2 mat filter 3 = G3 mat filter

Controls package

D 3 0 0 1 B A

<b>Controller type</b>	0 = Terminal box 2 = MATRIX 2000 3 = MATRIX 3000 4 = MATRIX 4000
<b>Controller package no.</b>	
<b>Terminal</b>	IP20 A = OP21C B = OP30C C = OP31C D = OP44C E = OP50C F = OP51C N = IR 1 = CMS 2 = CMT4D 3 = CMT2D 4 = CMT2Z J = CET.ACEC U = OP20C Z = without control panel
<b>Unit type</b>	Single/master unit, control panel A = Enclosed B = installed C = Master unit without control panel Slave unit D = W/o control panel

Valve code

V G F R 3 1 6 R 3 0 6 4 L

<b>Operating mode</b>	0 = DX-connection w/o expansion valve (only cooling circuit) R = 3-point 230 V T = 2-point 230 V N = 3-point 24 V Q = 2-point 24 V S = 0-10 V, 24 V C = 3-point 230 V + 2 contacts E = Expansion valve R410A (only cooling circuit)
<b>Valve body</b>	0 = DX-connection with or w/o expansion valve (only cool circuit) 2 = 2-way 3 = 3-way
<b>K<sub>vs</sub>-value</b>	00 = W/o expansion valve (only cooling circuit) 03 = K <sub>vs</sub> 0.25 (R, N, S, C) 04 = K <sub>vs</sub> 0.40 (R, N, S, C) 06 = K <sub>vs</sub> 0.63 (R, N, S, C) 10 = K <sub>vs</sub> 1.0 (R, N, S, C) 16 = K <sub>vs</sub> 1.6 (R, N, S, C, T, Q) 25 = K <sub>vs</sub> 2.5 (R, N, S, C, T, Q) 40 = K <sub>vs</sub> 4.0 (R, N, S, C) S1- = Setting expansion valve (only cooling circuit) S8 = Setting expansion valve (only cooling circuit)
<b>Connection/shut-off</b>	0 = Inlet/outlet flow with outside thread 1 = Inlet/outlet with solder fitting 2 = Inlet/outlet + ball trap with external thread 3 = Inlet/outlet + ball trap with solder fitting 4 = Inlet + ball trap/outlet + shut-off valve with external thread 5 = Inlet + ball trap/outlet + shut-off valve with solder fitting
<b>Medium connection</b>	L = Left R = right

Casing code

Z G F 1 C 0 1 2

<b>Model size</b>	1 = Model size 1 2 = Model size 2 3 = Model size 3 4 = Model size 4 5 = Model size 5 6 = Model size 6 7 = Model size 7 8 = Model size 8
<b>Accessory class</b>	C = Comfort casing E = Economy casing

<b>Casing design **</b>	01 = Circulating air ↗↖ - supply air ↗↖ (for recirculating-air units, air flow A)
02 = Circulating air ↗↖ - supply air ↘↙ (for recirculating-air units, air flow B)	
03 = Circulating air ↗↖ - supply air ↗↖ (for recirculating-air units, air flow C)	
04 = Circulating air ↗↖ - supply air ↘↙ (for recirculating-air units, air flow D)	
05 = Circulating air ↗↖ - supply air ↗↖ + foot cover (for recirculating-air units, air flow A)	
06 = Circulating air ↗↖ - supply air ↘↙ + foot cover (for recirculating-air units, air flow B)	
07 = Circulating air ↗↖ - supply air ↗↖ + unit foot cover + air intake grille (for recirculating units, air flow A - mixed air units, air flow A, C)	
08 = Circulating air ↗↖ - supply air ↘↙ + unit foot cover + air intake grille (for recirculating units, air flow B - mixed air units, air flow B, D)	
13 = Circulating air ↗↖ - supply air ↘↙ + with a rear shift (for recirculating-air units, ceiling, air flow C)	
23 = Circulating air ↗↖ - supply air ↗↖ + rear wall (for recirculating units, vertical floor installation, air flow C)	

<b>Discharge</b>	1 = Rigid grille 2 = Adjustable grille 3 = Rigid aluminium grille (discharge top/front)
------------------	---

**Note!**  
The models highlighted in grey are available on request.

\*) Front connection side, facing discharge

\*\*) Air flow is first indicated for a wall unit and then for a ceiling unit Refer to definition Page 74 Fig. 28.

## **EXCELLENCE IN SOLUTIONS**

FläktGroup is the European market leader for smart and energy efficient Indoor Air and Critical Air solutions to support every application area. We offer our customers innovative technologies, high quality and outstanding performance supported by more than a century of accumulated industry experience. The widest product range in the market, and strong market presence in 65 countries worldwide, guarantee that we are always by your side, ready to deliver Excellence in Solutions.

### **PRODUCT FUNCTIONS BY FLÄKTGROUP**

Air Treatment | Air Movement | Air Diffusion | Air Distribution | Air Filtration  
Air Management | Air Conditioning & Heating | Controls | Service

» Learn more on [www.flaktgroup.com](http://www.flaktgroup.com)  
or contact one of our office